



# INSTALLATION INSTRUCTIONS

Accessory

**FOG LIGHTS**  
P/N 08V31-SHJ-100A

Application

**2008 ODYSSEY**

Publications No.

**All 38138-38330**

Issue Date

**NOV 2007**

## PARTS LIST

Left fog light

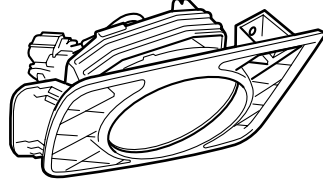

Right fog light

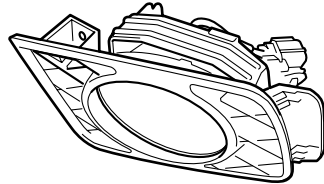

Fog light harness

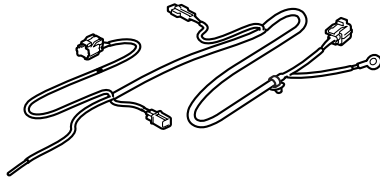

Short subharness  
(With LX model)

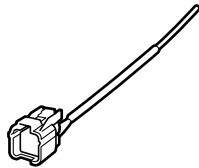

Long subharness  
(With EX model and Touring)

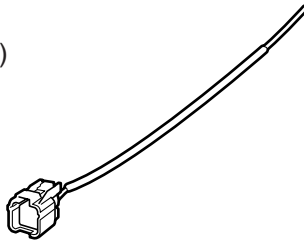

Relay bracket



Relay

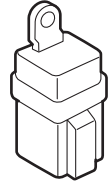

22 Wire ties

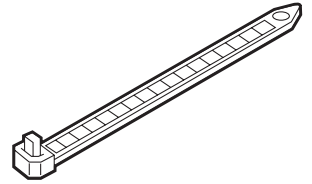

Wire tie with holder

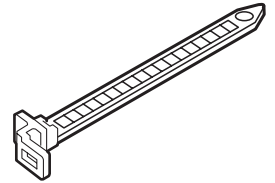

5 Wire ties with clip

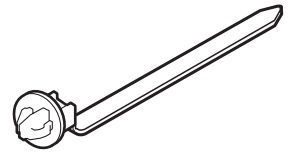

2 Small wire ties

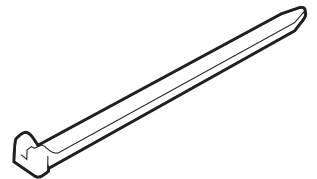

2 Tapes



Washer-bolt, 6 x 16 mm

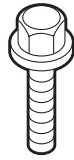

2 Self-tapping screws

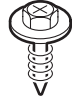

Ground bolt

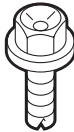

Grommet



EPT sealer

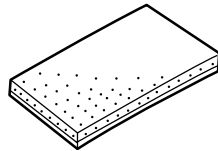

2 Spring nuts



Fuse label  
(LX model only)

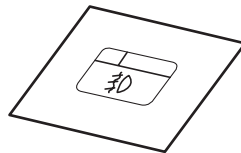

20 A Fuse  
(LX model only)



Lighting switch

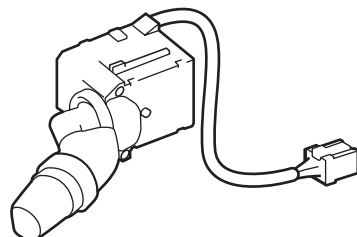

## TOOLS AND SUPPLIES REQUIRED

Phillips screwdriver

Stubby #2 Phillips screwdriver

10 mm Socket

Ratchet

Diagonal cutters

10 mm Combination wrench

Flat-tip screwdriver

Blanket

Isopropyl alcohol

Shop towel

Scissors

## INSTALLATION

**Customer Information:** The information in this installation instruction is intended for use only by skilled technicians who have the proper tools, equipment, and training to correctly and safely add equipment to your vehicle. These procedures should not be attempted by "do-it-yourselfers."

### NOTE:

- Be careful not to damage the body finish.
  - Take care not to damage the clips and tabs.
1. Make sure you have the anti-theft code for the radio, then write down the radio station presets.
  2. Disconnect the negative cable from the battery.
  3. Remove the radiator cover (eight clips).

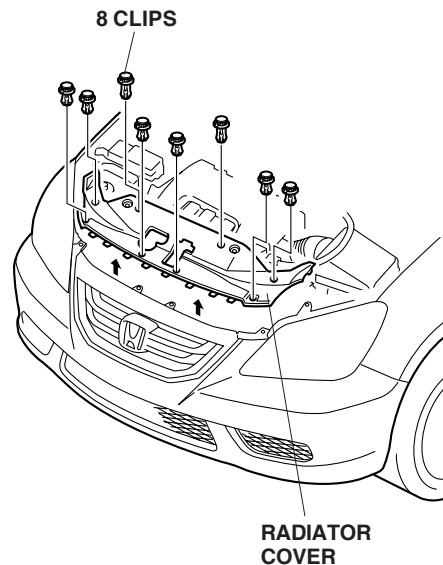

4. Remove the front bumper.
  - On each side, pull down the inner fender cover and remove the four self-tapping screws.
  - Remove the eight clips.
  - Remove the two clips, and have an assistant help you remove the front bumper.
  - Place the front bumper on a blanket.

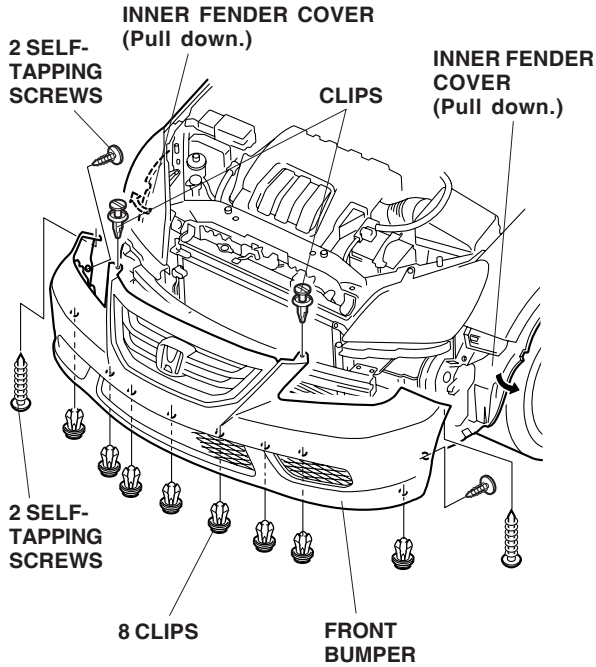

### Routing the Fog Light Harness

5. Open the hood. Remove the FI-ECU cover (two clips and one tab).

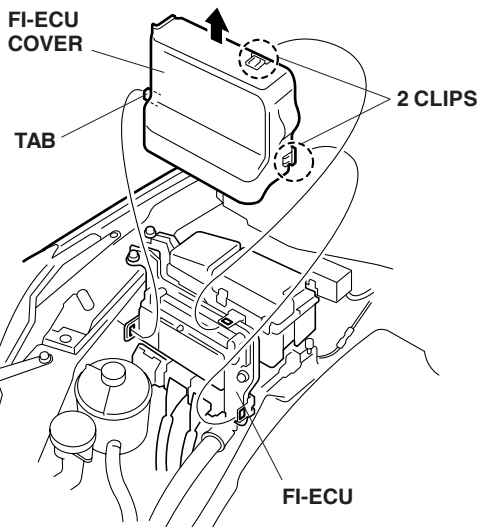

6. Remove the under-hood fuse relay box cover, two bolts, and one retaining tab, and move the under-hood fuse relay box to the side.

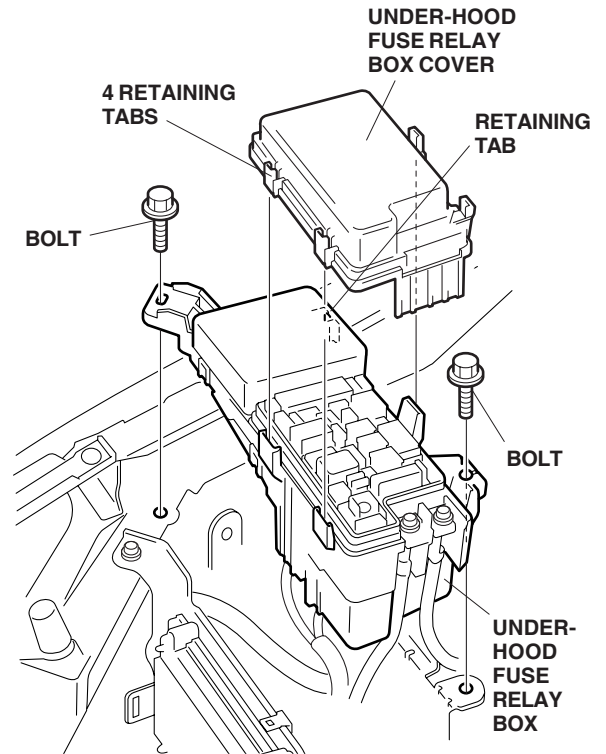

- Remove the under-hood fuse/relay box lower cover from the under-hood fuse/relay box (six retaining tabs).

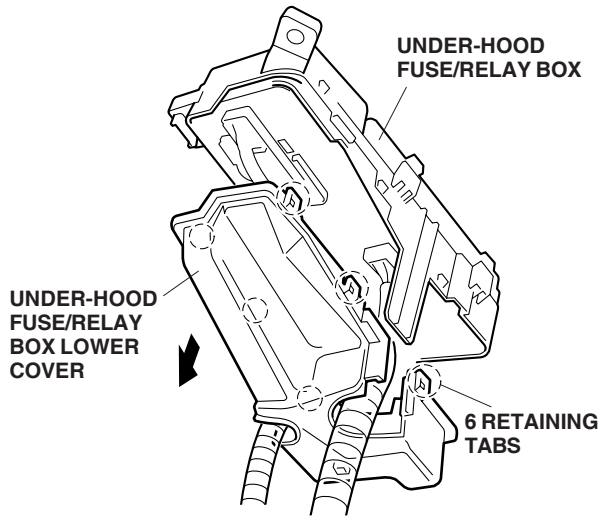

If the vehicle you are working on is an LX model, go to step 19; otherwise, continue with step 8.

- Near the under-hood fuse/relay box, locate the sub fuse box. Remove the sub fuse box cover (two tabs).

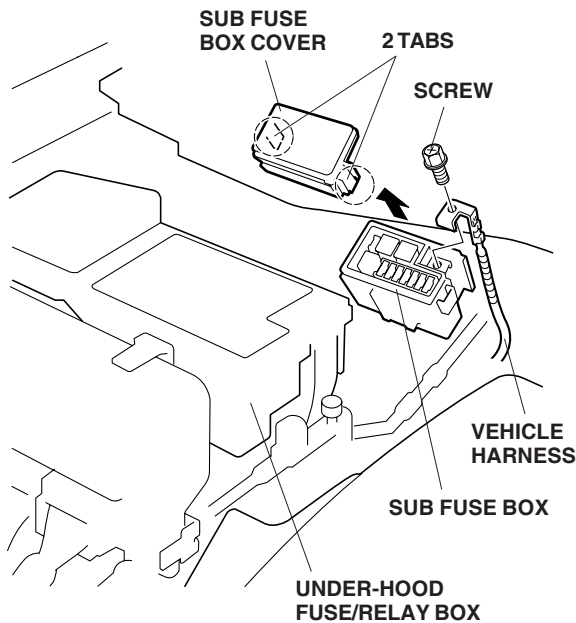

- Remove the screw and disconnect the vehicle harness.

- Remove the sub fuse box from the vehicle bracket.

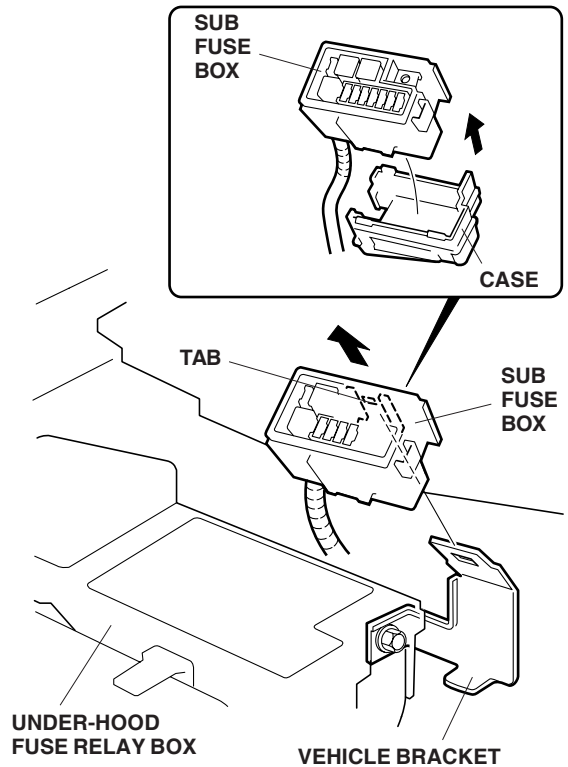

- Remove the sub fuse box from the case (one tab).
- Get the long subharness. Plug the 1-pin terminal from the long subharness into the rear of sub fuse box at the location shown.

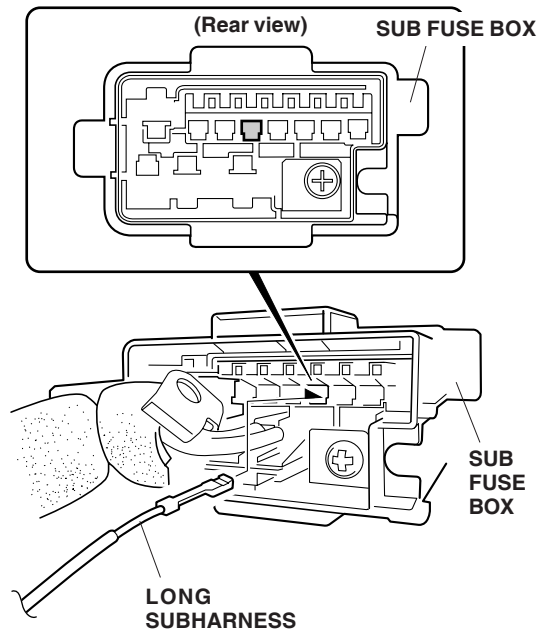

- Secure the long subharness to the sub fuse box harness with one small wire tie.

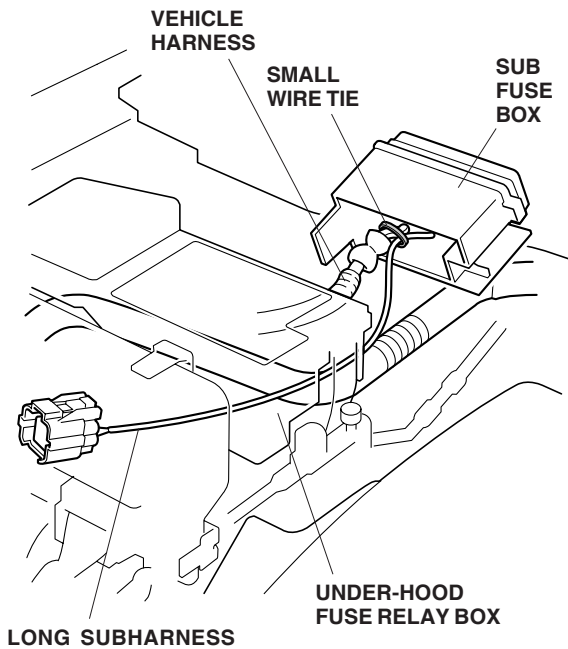

- Reinstall the sub fuse box.
- Secure the long subharness to the vehicle harness with one wire tie.

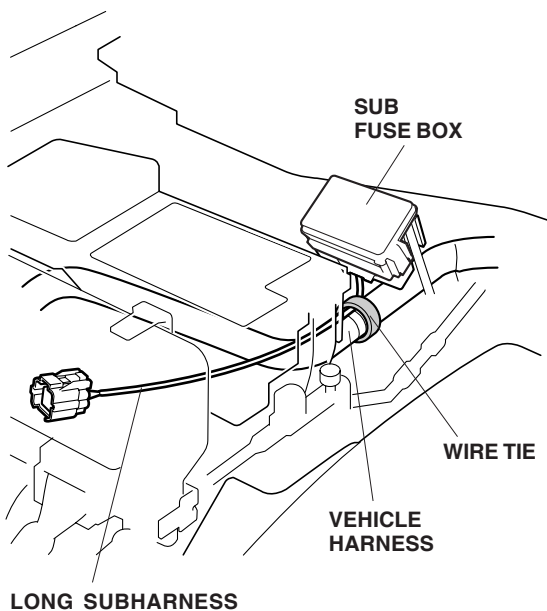

- Disconnect the vehicle 18-pin connector from the back of the under-hood fuse/relay box.

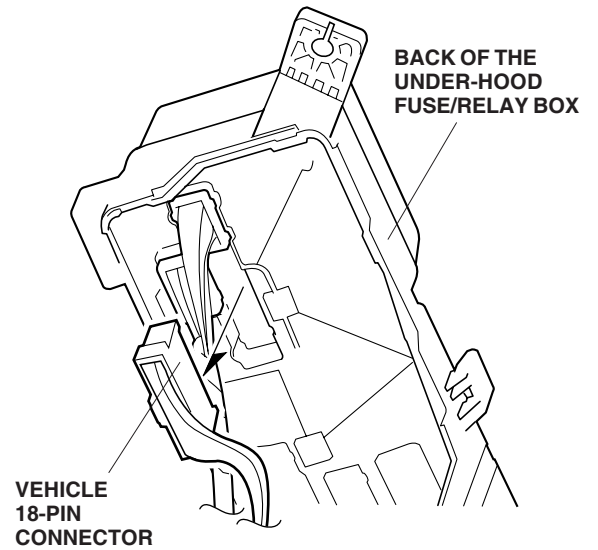

- Get the fog light harness. Release the lock on the vehicle 18-pin connector as shown, and plug the terminal of the fog light harness into the back of the 18-pin connector in the location shown.

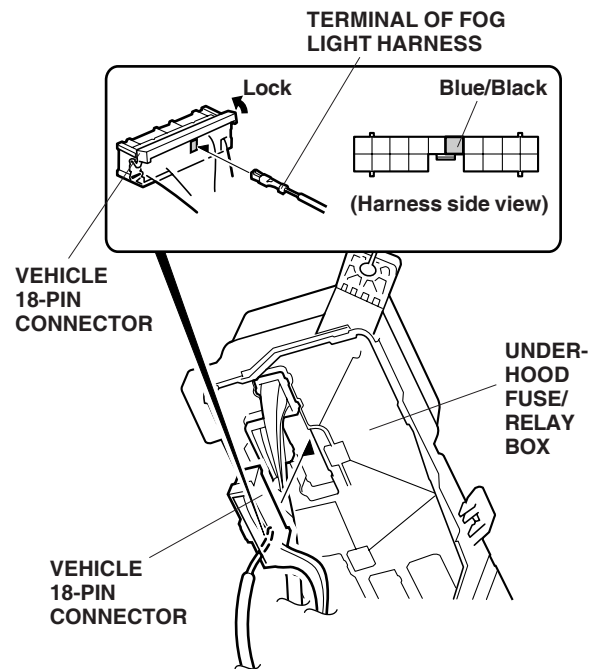

- Reconnect the vehicle 18-pin connector into the under-hood fuse/relay box. For the LX model, go to step 19. For the EX model, go to step 22.

19. Disconnect the vehicle 20-pin connector from the bottom of the under-hood fuse/relay box.

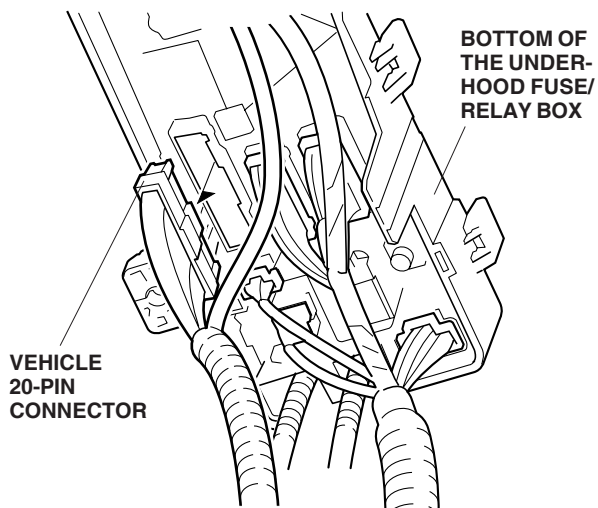

20. Get the short subharness, and plug the 1-pin terminal from the short subharness into the back of the vehicle 20-pin connector.

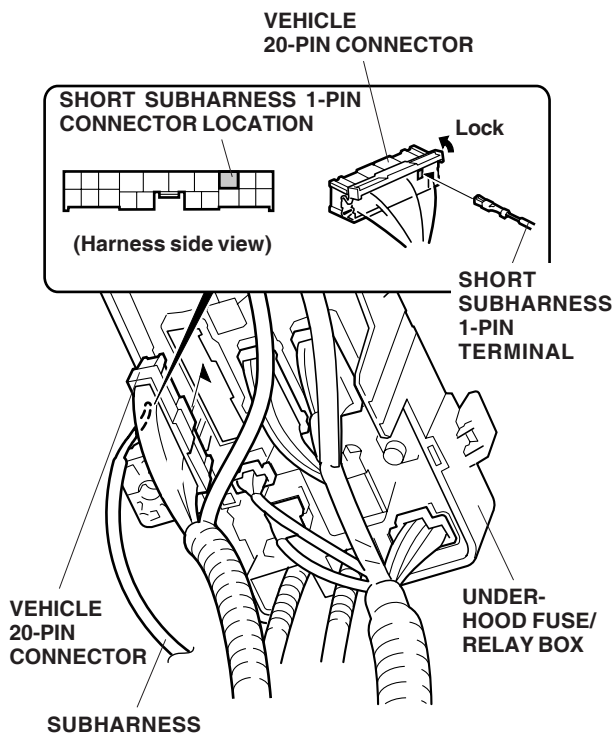

21. Reconnect the vehicle 20-pin connector into the under-hood fuse/relay box.

22. Plug the connector from the long/short subharness into the fog light harness connector. Secure the fog light harness and the subharness to the vehicle harness with one small wire tie.

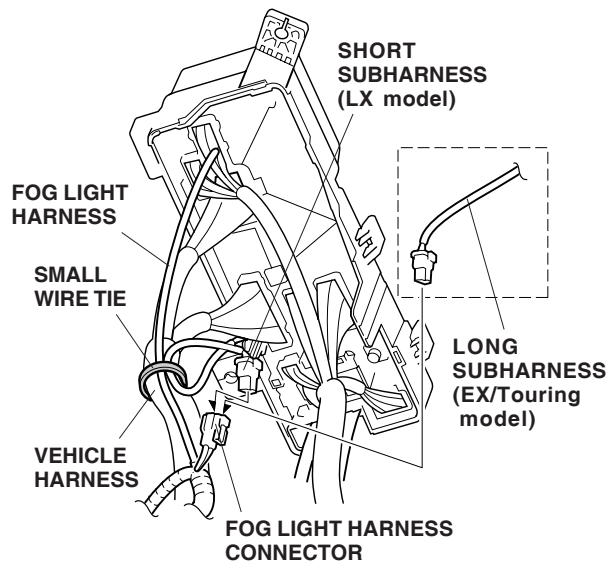

23. Reinstall the under-hood fuse/relay box lower cover in the original position.
24. Below the under-hood fuse relay box, secure the fog light harness connector to the vehicle harness using the wire tie with holder.

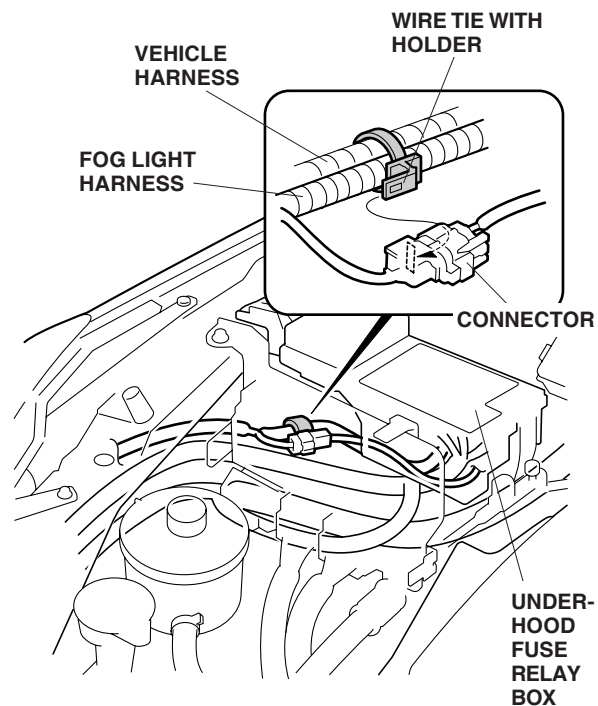

25. Route the fog light harness 2-pin connector (short side) forward along the vehicle harness, and loosely secure it to the vehicle harness with two wire ties.

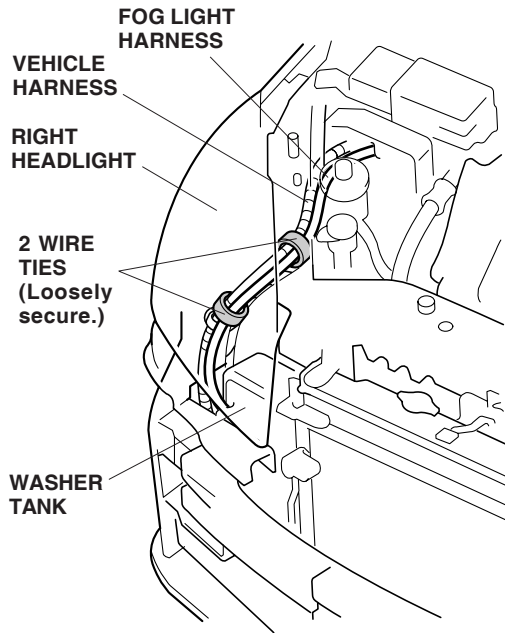

26. Route the fog light harness 2-pin connector along the vehicle harness and into the bumper area.

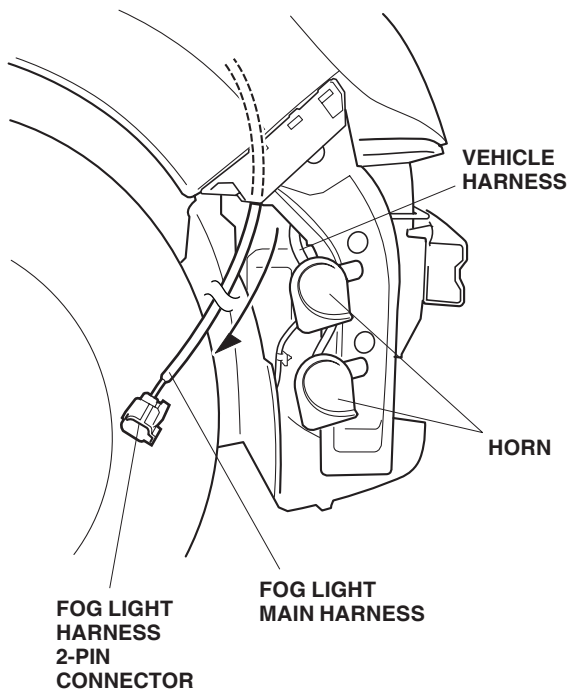

27. Attach the two wire ties with clip from the fog light harness into the holes in the vehicle body.

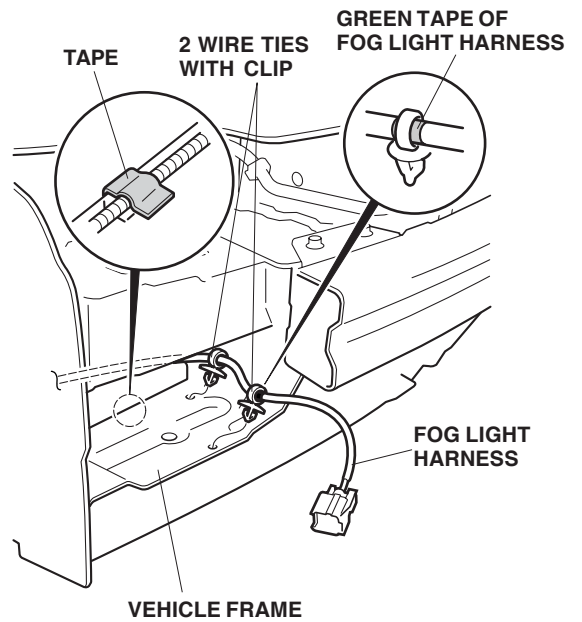

28. Using isopropyl alcohol, thoroughly clean the areas where the tape will attach. Secure the fog light harness to the vehicle's frame with the tape.

29. Secure the fog light harness to the vehicle harness with two wire ties.

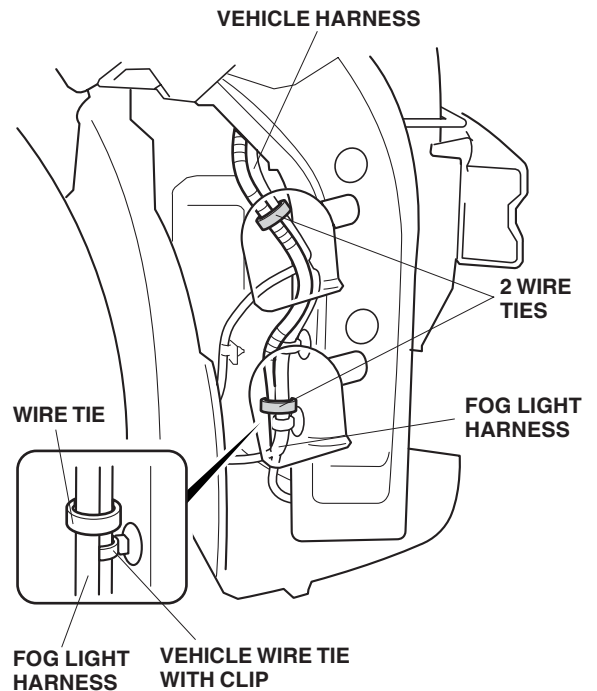



30. Tighten the two wire ties from step 25.

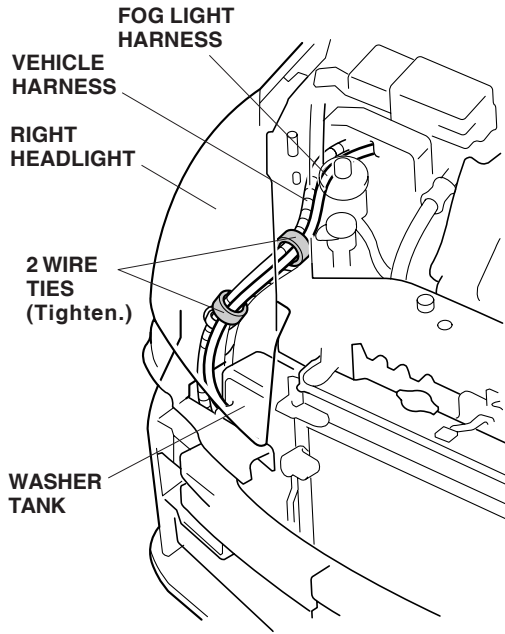

31. Reinstall the under-hood fuse relay box.

32. Remove the power steering reservoir from the vehicle bracket.

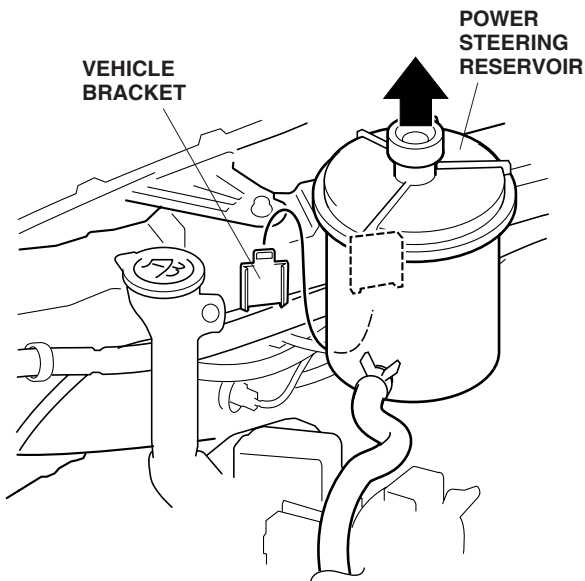

33. Route the fog light harness along the vehicle harness. Attach the fog light harness to the vehicle harness with three wire ties.

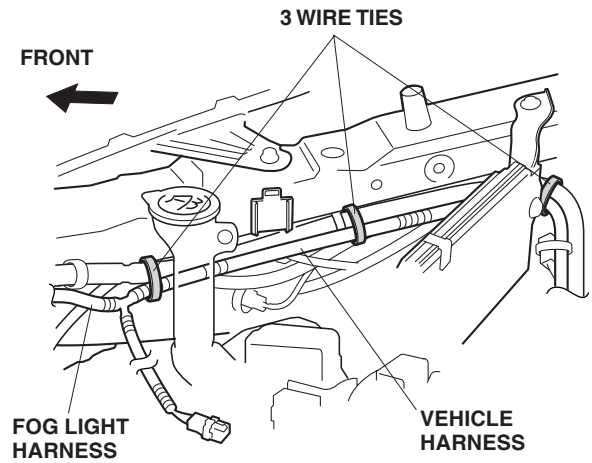

34. Route the fog light harness along the vehicle harness of the bulkhead, and loosely secure the fog light harness to the vehicle harness with five wire ties.

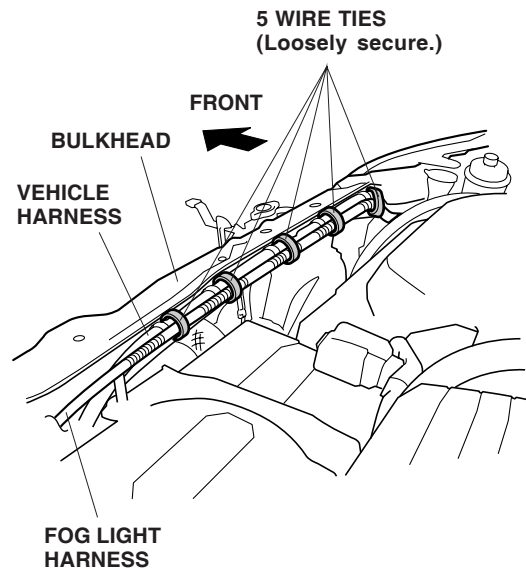



35. Route the fog light harness past the battery, and loosely secure it to the vehicle harness with three wire ties.

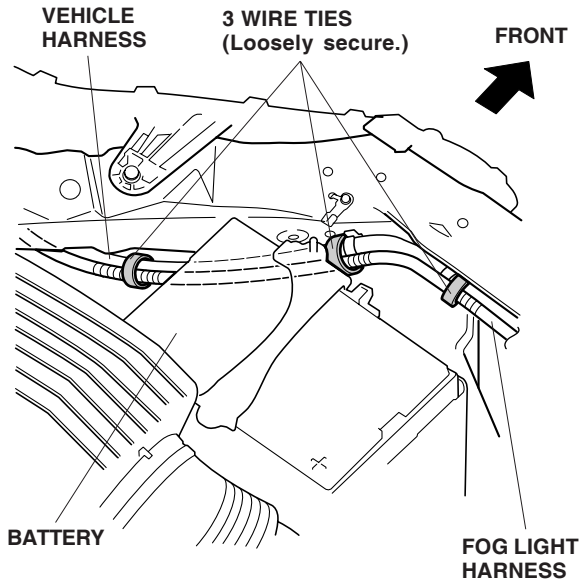

36. Locate the wire tie with clip near the end of the fog light harness. Wrap an EPT sealer around the fog light harness at the measurement shown.

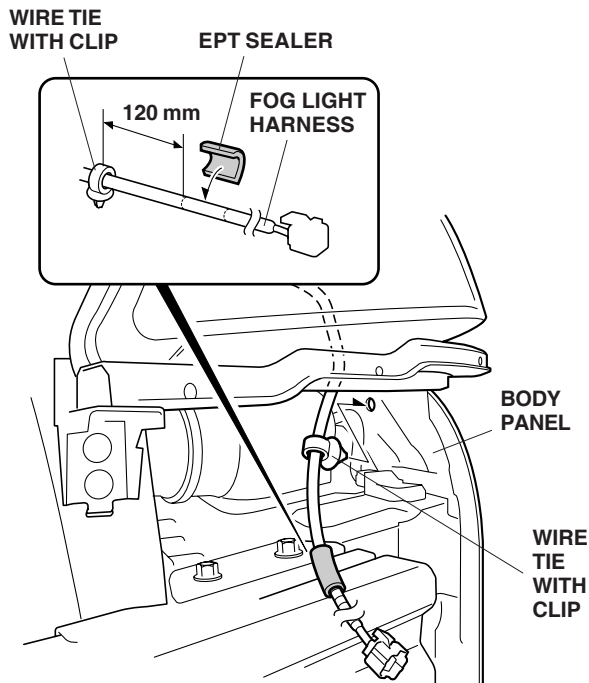

37. Attach the wire tie with clip from the fog light harness into the hole in the body panel.

38. Remove the vehicle bolt.

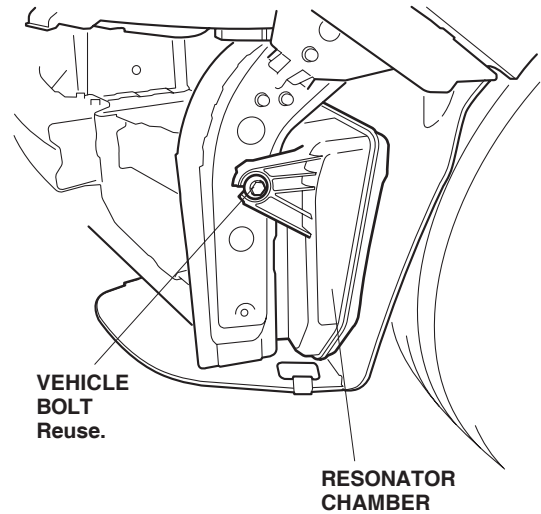

39. Route the fog light harness as shown.

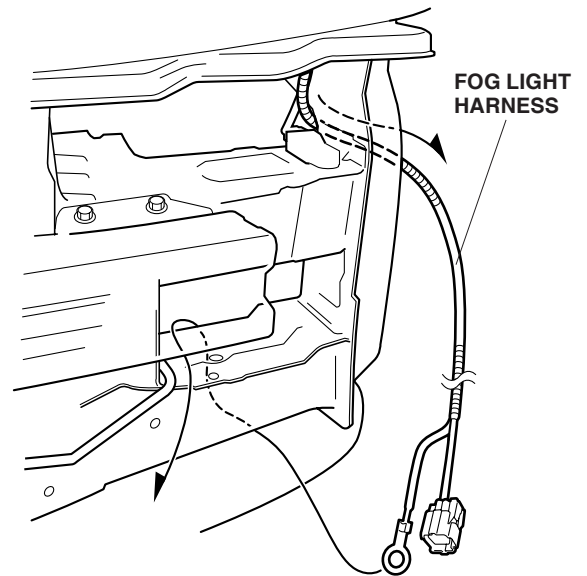

40. Reinstall the vehicle bolt removed in step 38.

**If equipped with AUTO air conditioner:**

- Remove the vehicle bolt from the vehicle bracket. Secure the ground terminal from the fog light harness to the vehicle bracket using the ground bolt supplied.

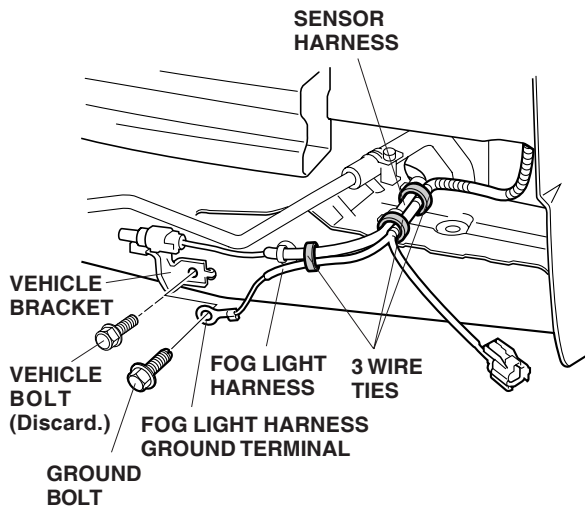

- Secure the fog light harness to the sensor harness using three wire ties. Go to step 45.

**If equipped with MANUAL air conditioner:**

- Use the ground bolt and tighten the ground terminal of the fog light harness to the vehicle frame.

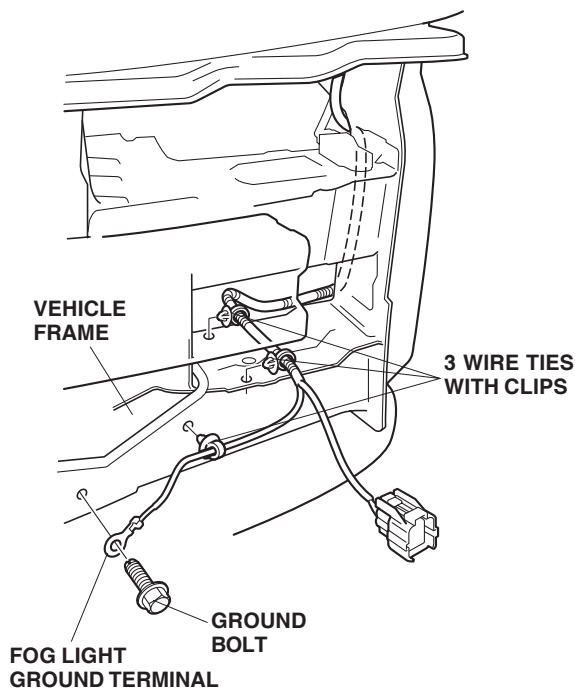

- Route the fog light harness as shown, and secure it with three wire ties with clip to the vehicle frame.

- Using isopropyl alcohol, thoroughly clean the area where the tape will attach. Secure the fog light harness to the vehicle frame with one cushion tape.

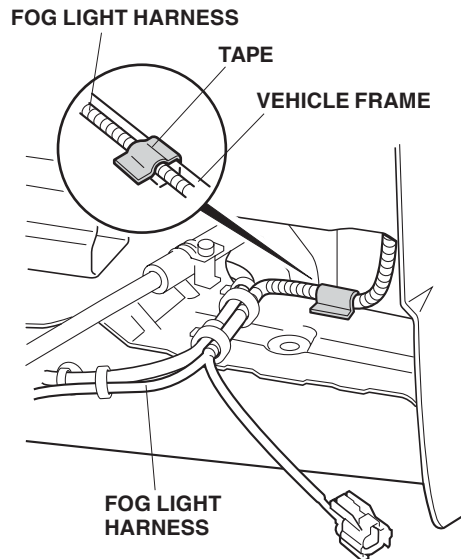

- Tighten the eight wire ties you loosely secured to the vehicle harness.

- Get the relay bracket and the relay. Attach the relay to the relay bracket using 6 x 16 mm washer-bolt.

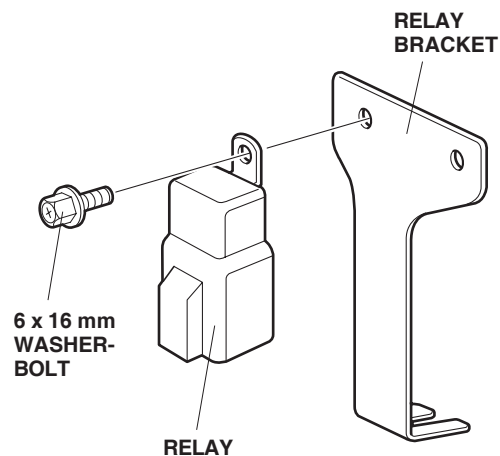

48. Plug the fog light harness 4-pin connector into the relay.

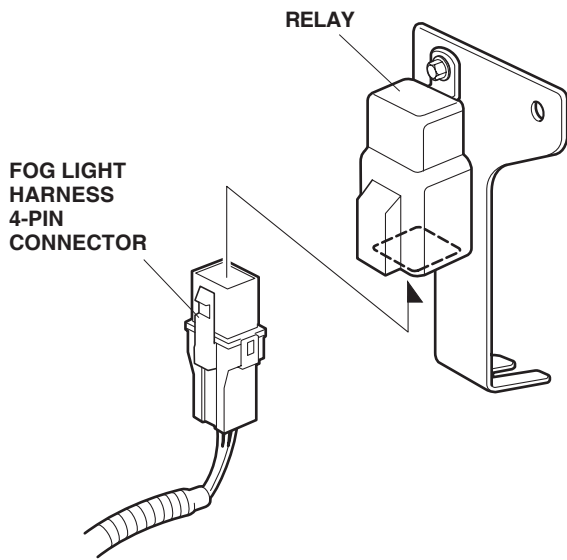

49. Loosen the bolt securing the existing relay box, and slide the tab from the fog light relay bracket under the bolt. Retighten the relay bracket bolt.

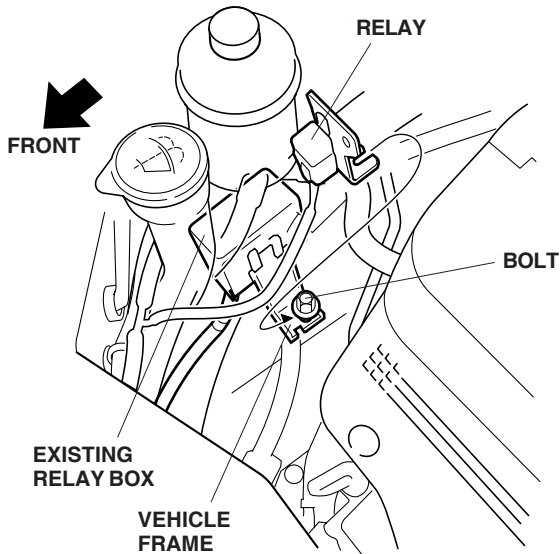

50. Secure the fog light harness from the relay box to the vehicle harness with three wire ties.

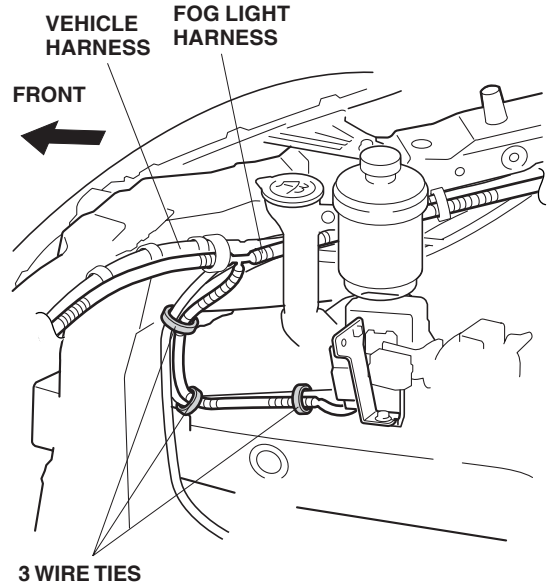

51. Remove the cover from the front bumper (four retaining tabs).

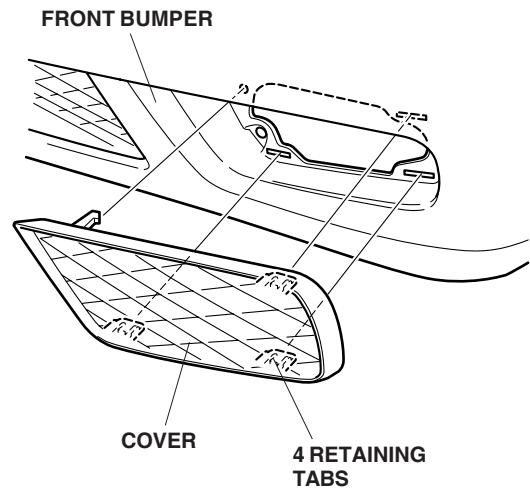

52. Slide the spring nut onto the cover opening as shown.

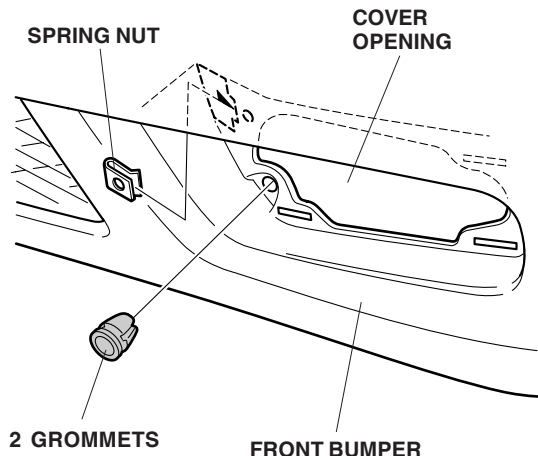

53. Install the nut to the front bumper.  
 54. Repeat steps 51 thru 53 on the right side.  
 55. Reinstall the front bumper in its original position, and route the fog light harness 2-pin connectors through each cover opening. Make sure that the fog light harness does not get caught.

NOTE: Have an assistant help you when removing and installing the front bumper.

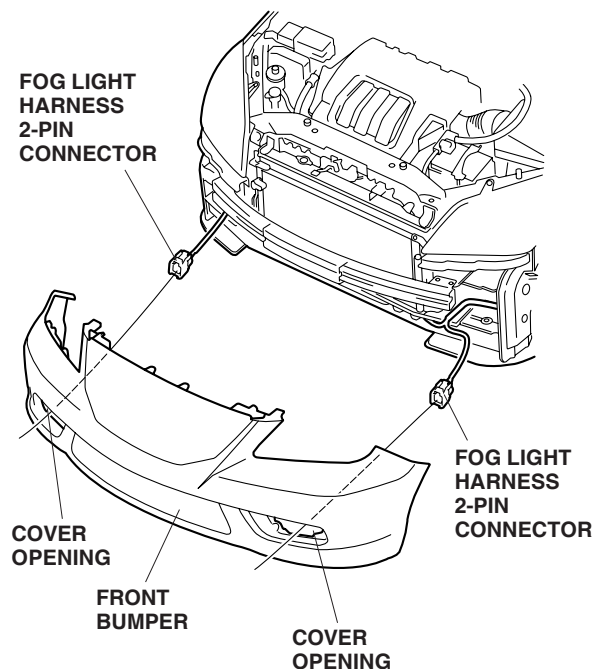

56. Plug the fog light harness 2-pin connectors into the fog lights.

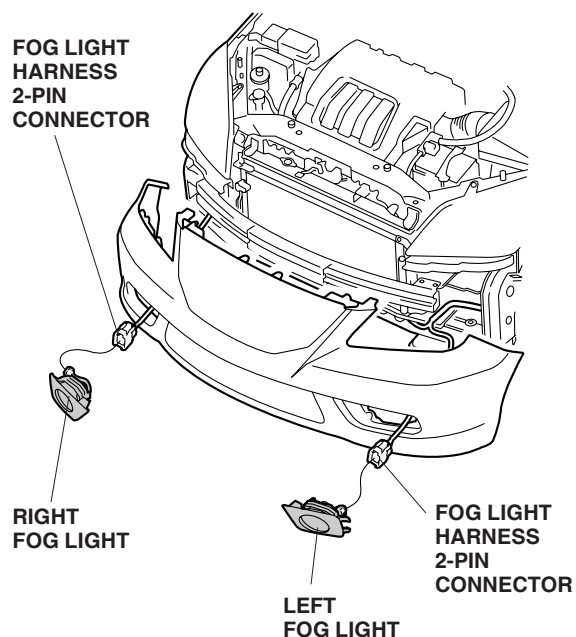

57. Insert the hook into the cover opening and insert the pivot to the nut installed in step 53.  
 58. Install the left fog light on the front bumper using the 5 x 16 mm self-tapping screw.

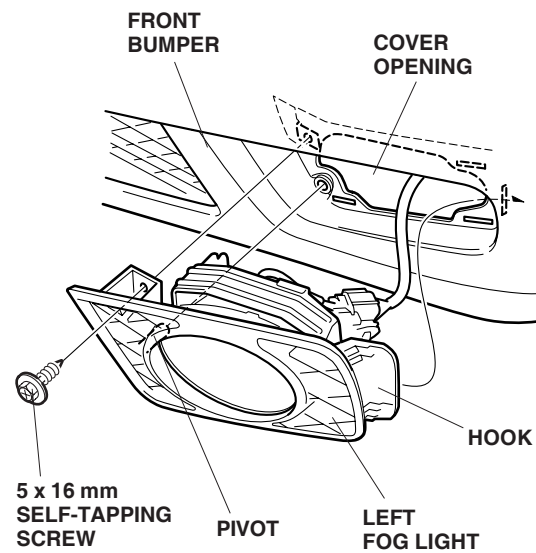

59. Repeat steps 57 thru 58 on the right side.

## Installing the Fog Light Switch

60. Remove the steering column upper cover (six retaining tabs).

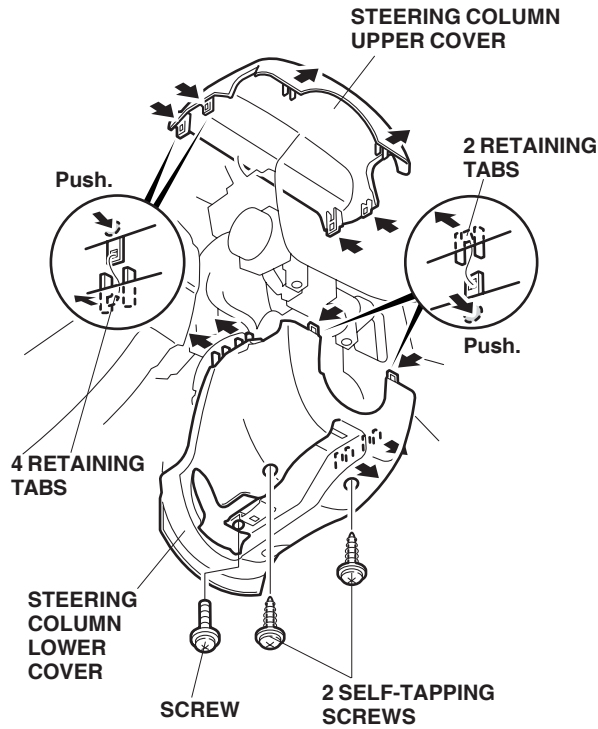

61. Remove the steering column lower cover (one screw and two self-tapping screws).

62. Unlock the steering column tilt lever. Pull the steering wheel out towards you and down. Drop the steering column lower cover down to access the lighting switch.

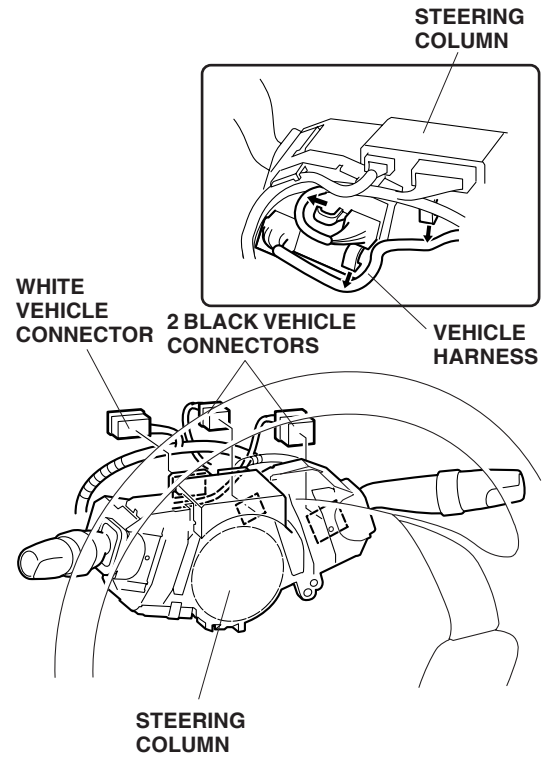

63. Disconnect the three vehicle connectors from the steering column.

64. Turn the steering wheel counterclockwise as shown. Remove the two self-tapping screws from the lighting switch. While pushing the retaining tab, slide the lighting switch and remove it from the steering column. Do not pull out the lever when removing the case. Do not damage the tab hole of the steering column.

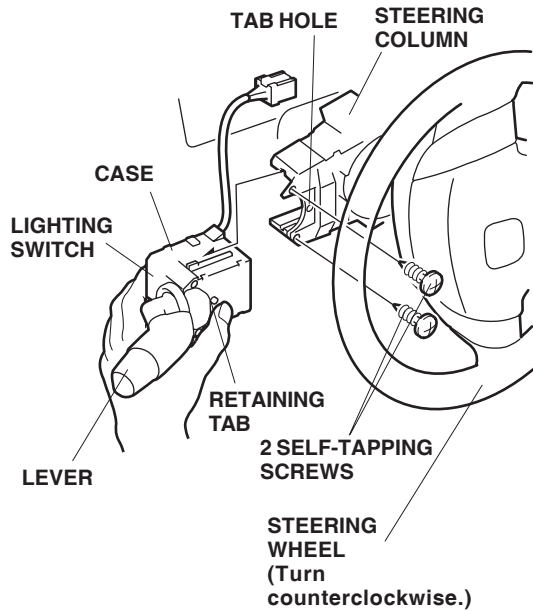

65. Install the new lighting switch on the steering column using the two self-tapping screws. Hold the case by hand, then install the new lighting switch to the steering column. Do not push the lever when installing the case. Push the case and set the retaining tab to the tab hole securely.

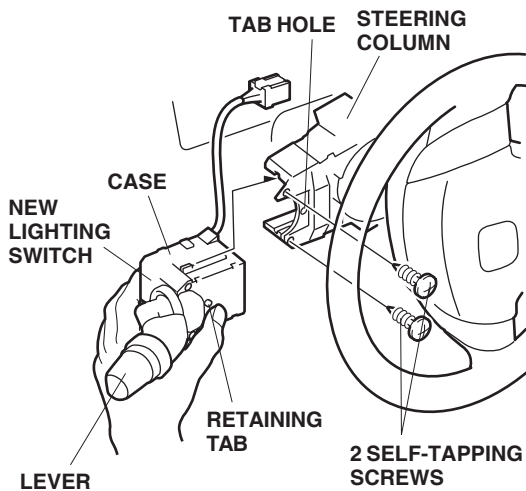

66. Install the 20 A fog light fuse.

**EX/EX-L:** Install the 20 A fuse into the sub fuse box in the location shown.

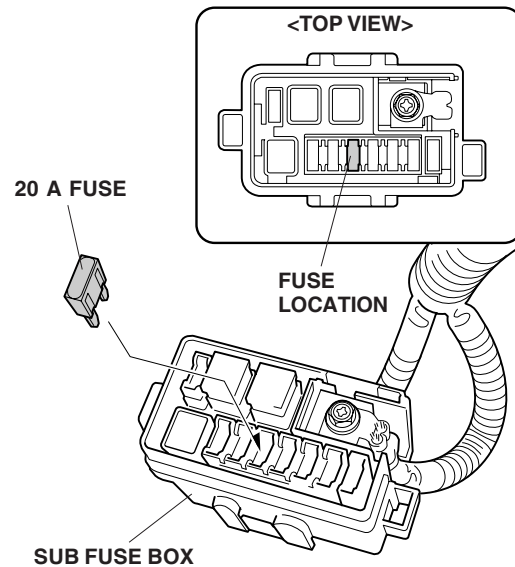

**LX model:** Install the 20 A fuse into the under-hood fuse relay box in the location shown.

**FUSE LOCATION**

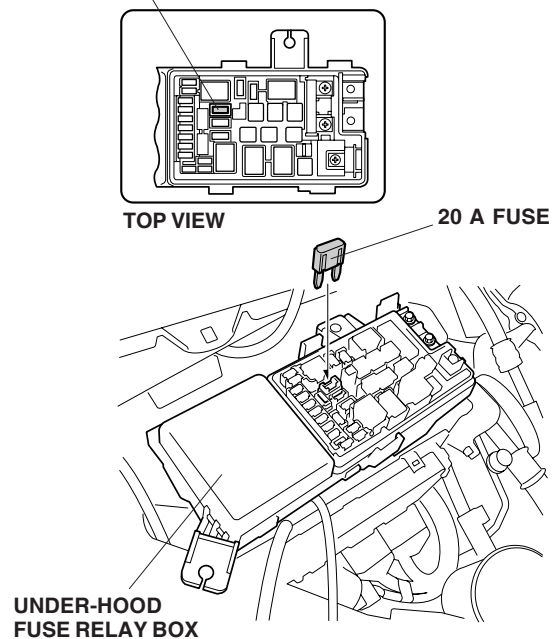

67. **LX model only:** Attach the 20 A fuse label to the inside of the under-hood fuse relay box.

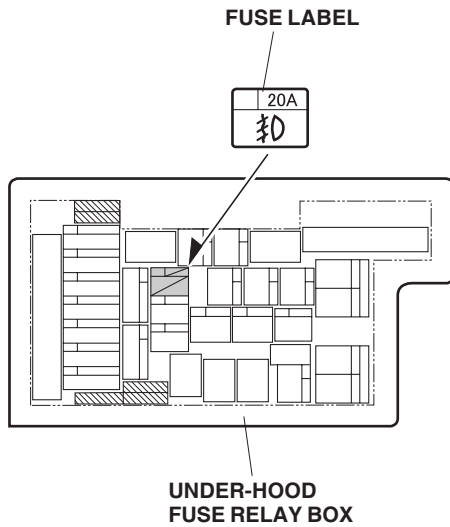

68. Check that all wire harnesses are routed properly and all connectors are plugged in.
69. Reinstall all removed parts.
70. Reconnect the negative cable to the battery.
71. Enter the customer's radio anti-theft code, and reset the station presets.
72. Reset the clock.

**NOTE:** When the battery is disconnected, the driver's window AUTO function is disabled.

- Start the engine. Push down on the driver's window switch until the window is fully open.
- Pull up on the driver's window switch to close the window completely, then hold the switch for 1 second or more.
- Lower and raise the driver's window to check operation of the driver's window AUTO function.

### Fog Light Aiming Adjustment

73. Adjust the fog lights.

- Adjust the aiming according to local laws and regulations.
- To adjust, turn the adjustment screw in or out until the correct aiming is obtained.

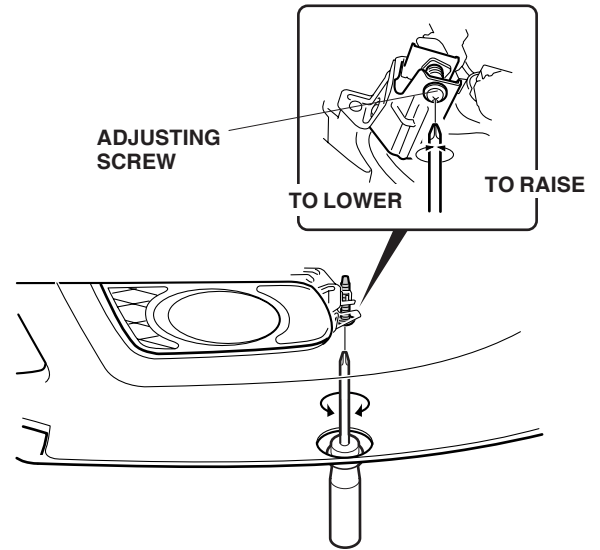



## USE AND CARE

### How to Operate Fog Lights

- Turn the lights switch to the “” position (headlights on low beam).
- Turn the fog light switch on (indicator is on).

NOTE: The fog light lenses may cloud when the outside temperature is cold; this is normal and should go away in warm weather.

- If the fog light does not come on, check the fuse and all the connectors, including the ground cable.

### Replacing the Bulb

NOTE:

- Use only a Honda Genuine halogen light bulb of specified wattage.  
BULB, FOG LIGHT (H11)  
P/N 33165-S5A-003
- Do not touch the bulb. Oily or greasy substances on the bulb can shorten its service life due to the heat produced when the bulb is turned on. If the bulb is accidentally touched, wipe it clean with a clean, soft cloth that has been dampened with denatured alcohol or a mild detergent solution.

1. Remove the fog light (5 x 16 mm self-tapping screw, pivot, hook, and disconnect the fog light harness 2-pin connector).

NOTE: Make sure that the nut is still installed to the cover opening. If the nut is removed with the left fog light, reinstall the nut onto the cover opening.

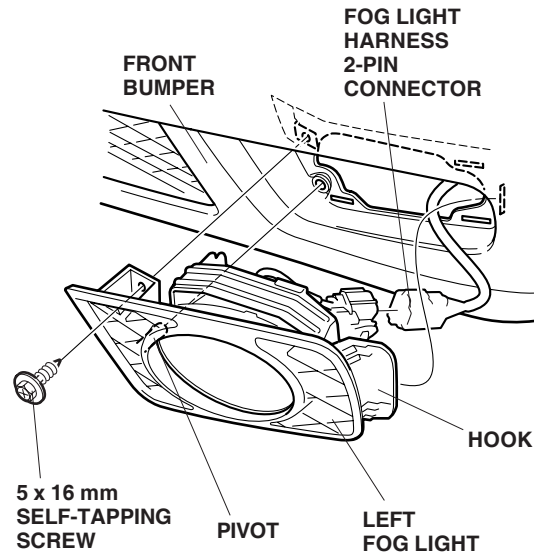

2. Disconnect the connector from the bulb and remove the bulb from the fog light.

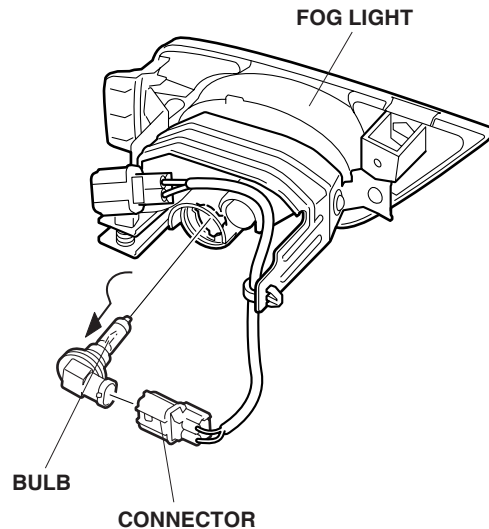

3. Install the new bulb into the fog light.

NOTE: When installing the new bulb, align the cutout on the fog light with the tab on the new bulb and turn the new bulb in completely. If not properly aligned, the fog light may blind oncoming drivers.

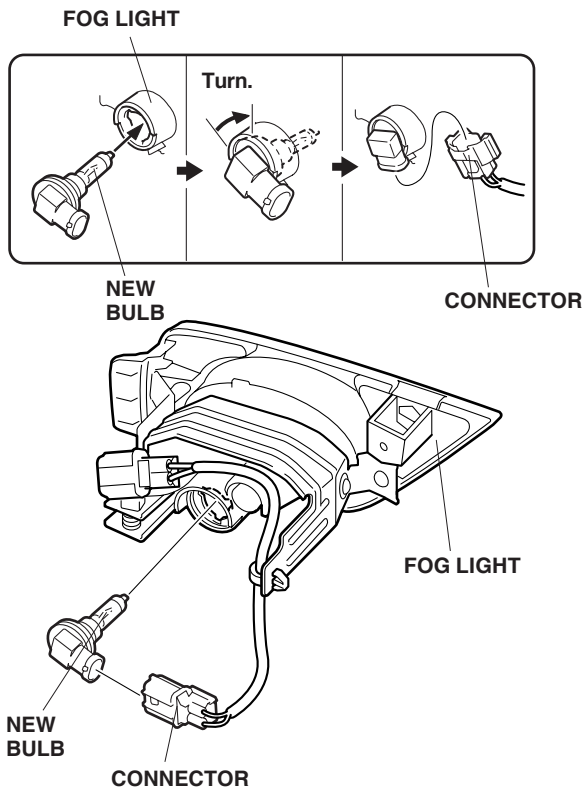

4. Reinstall the removed parts in the reverse order of removal.
  - Check that the wire harnesses are not pinched.
  - Be sure to tighten the self-tapping screw and bolts securely.
5. Check the operation of the fog light; adjust the aiming if necessary.

# CIRCUIT DIAGRAM

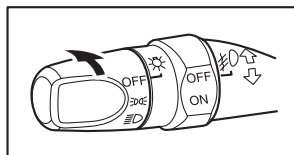
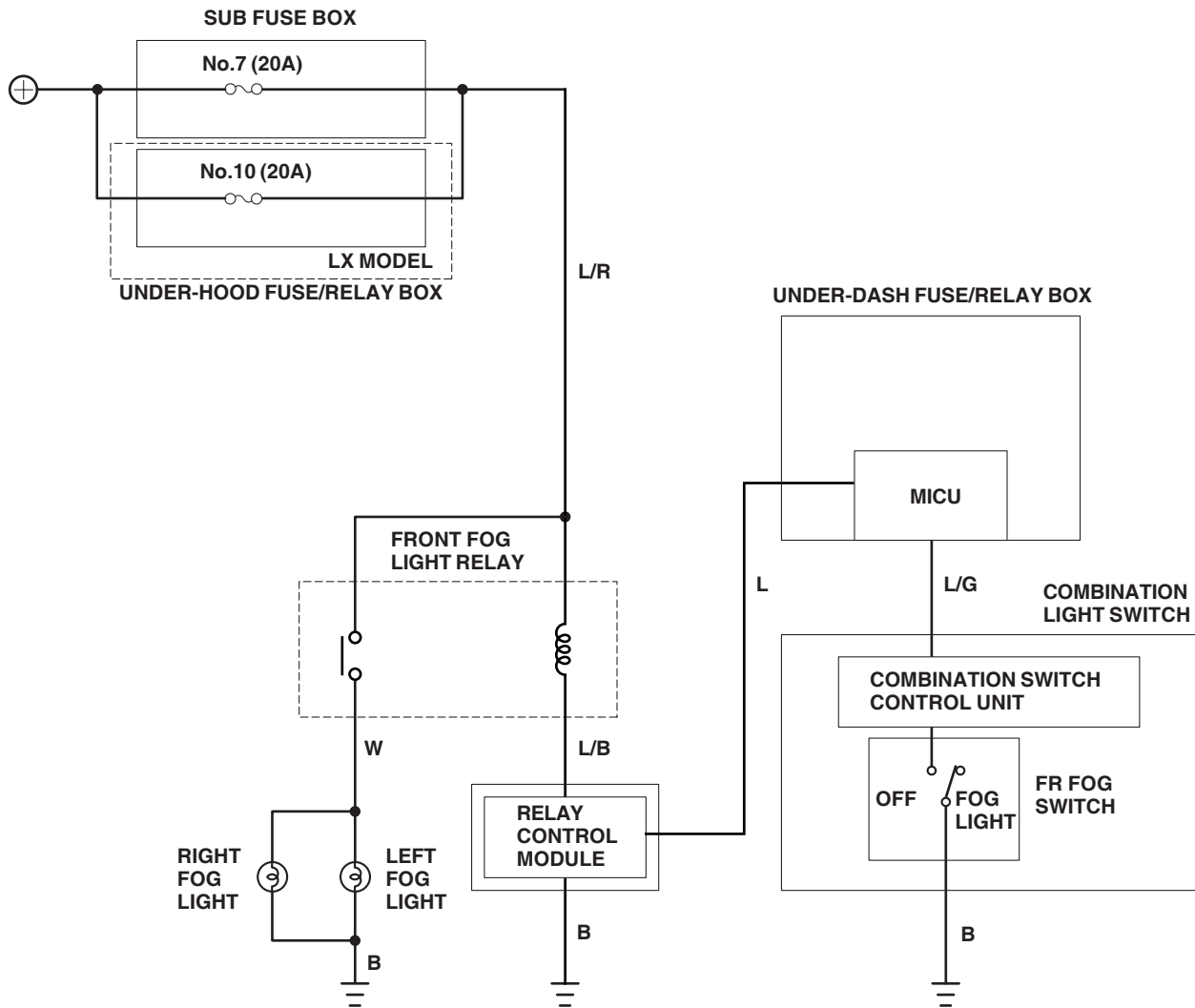

LIGHT SWITCH

OFF			Low	Hi
-----	--	--	-----	----

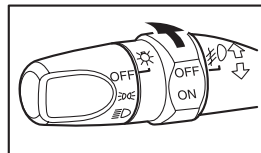

FOG LIGHT SWITCH

OFF	-	-	-	-
ON	-	-	ON	-

BLK	BLACK	BRN	BROWN
YEL	YELLOW	ORN	ORANGE
BLU	BLUE	PUR	PURPLE
GRN	GREEN	NAT	NATURAL
RED	RED	PNK	PINK
WHT	WHITE	GRY	GRAY
LT BLU	LIGHT BLUE	LT GRN	LIGHT GREEN