



# INSTALLATION INSTRUCTIONS

Accessory

**ENGINE BLOCK HEATER  
P/N 08T44-SNA-101**

Application

**2008 ODYSSEY**

Publications No.

**All 38140-38331**

Issue Date

**NOV 2007**

## PARTS LIST

Engine block heater

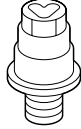

Aluminum washer



Heater harness

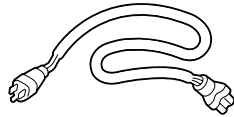

Protective cap

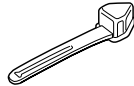

12 Black wire ties

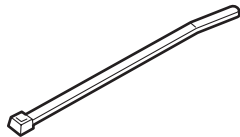

7 Wire tie with clips  
(Some may not be used.)

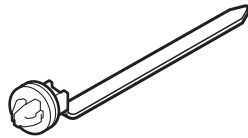

5 White wire ties  
(Some may not be used.)

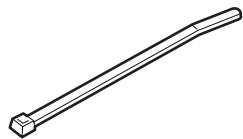

## TOOLS AND SUPPLIES REQUIRED

Phillips screwdriver

Ratchet

Extension (6 inch)

14, 19, and 24 mm Sockets

Torque wrench

Diagonal cutters

Coolant (Honda Antifreeze/Coolant only)

White marker

Tape measure

## NOTE

- Always use Honda Antifreeze/Coolant. Using a non-Honda coolant can result in corrosion, causing the cooling system to malfunction or fail.
- To avoid burning out the element, do not operate the engine block heater before it is installed in the vehicle and the coolant has been added.

## INSTALLATION

**Customer Information:** The information in this installation instruction is intended for use only by skilled technicians who have the proper tools, equipment, and training to correctly and safely add equipment to your vehicle. These procedures should not be attempted by “do-it-yourselfers.”

If the vehicle you are working on has a VTEC engine, continue with step 1. If equipped with a VCM2 engine, go to step 29.

### With VTEC Engine:

1. Allow the engine and all cooling system components to cool down.
2. Place a clean drain pan under the radiator drain plug, then remove the drain plug from the bottom of the radiator to drain the coolant. Remove the radiator cap to increase the flow.

**NOTICE** Radiator coolant will damage the body paint. Quickly rinse any spilled coolant from the painted surfaces.

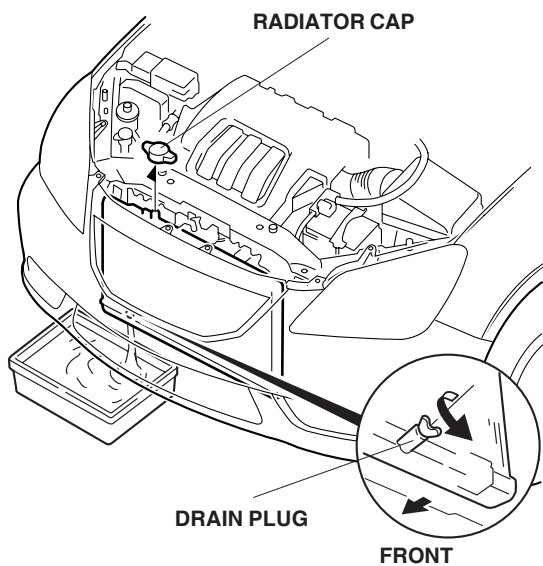

3. Remove the radiator cover (eight clips).

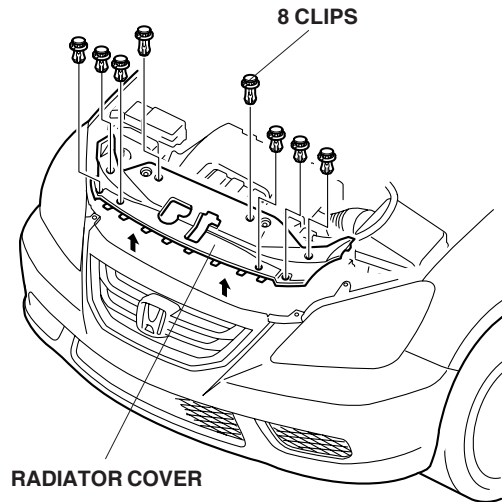

4. Take the cap off of the reservoir tank.

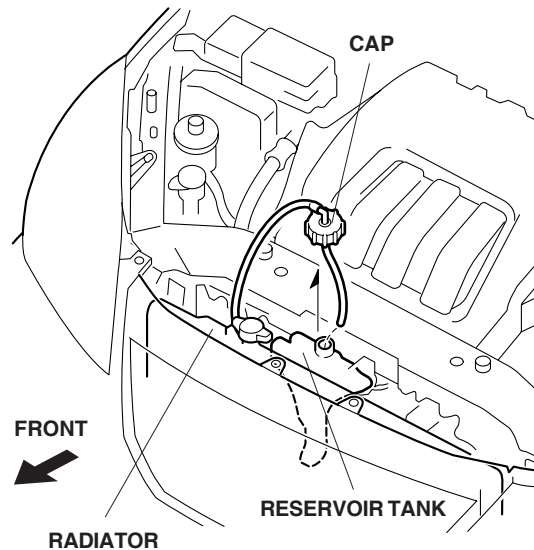

5. Remove two bolts from the reservoir tank.

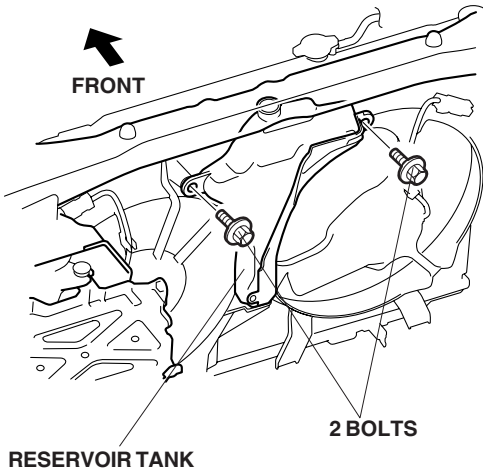

6. Remove the reservoir tank and the reservoir tank bracket (one tab).

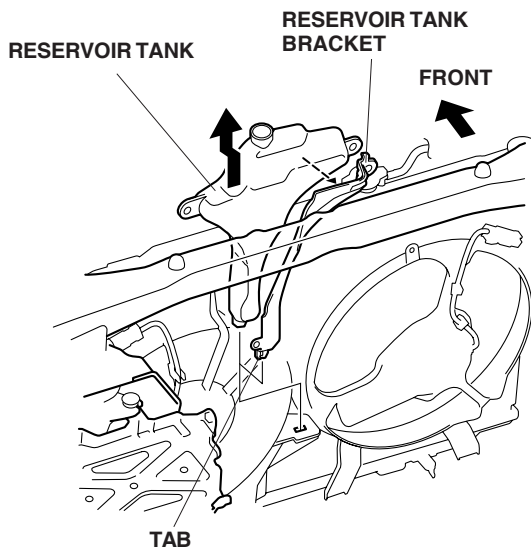

7. Remove two bolts from the radiator brackets, and remove the radiator brackets.

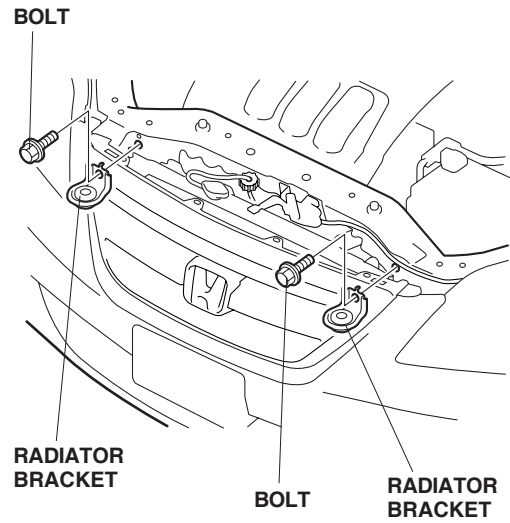

8. Remove the bolt from the lower oxygen sensor wire bracket, and move the bracket out of the way.

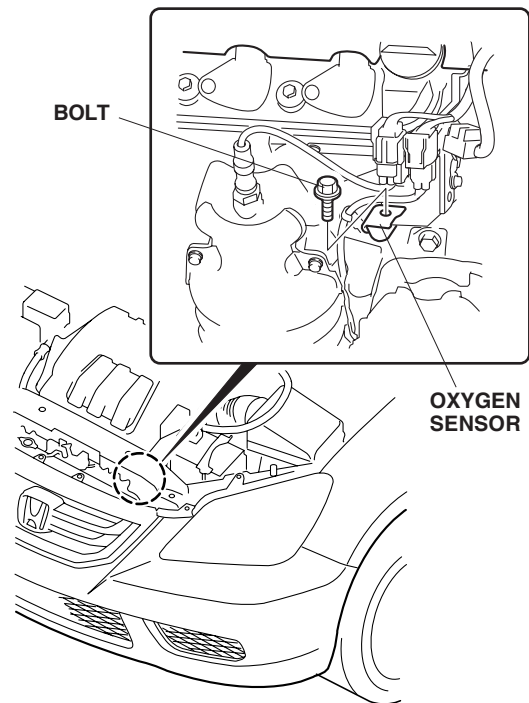

9. Locate and remove the drain bolt from the front of the block using a 19 mm socket. Coolant remaining in the engine jackets will flow out from the hole when the drain bolt is removed. (Retain the drain bolt, in case the engine block heater is removed.)

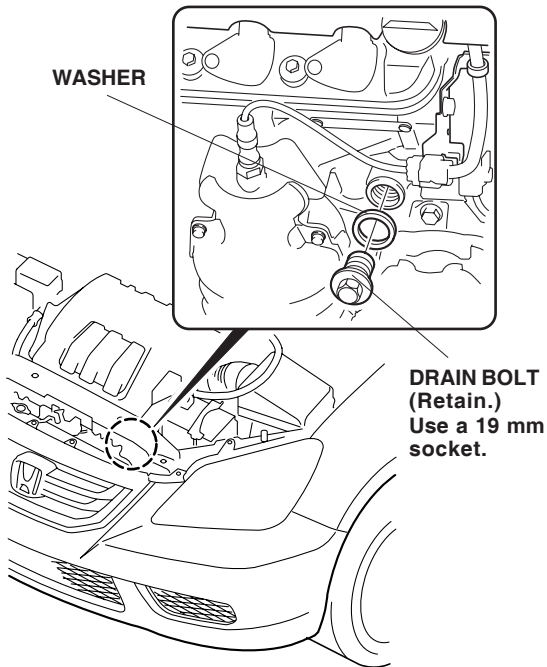

10. Install the engine block heater and the aluminum washer into the hole using a 24 mm socket. Torque the engine block heater to 60 N·m (44 lb-ft).

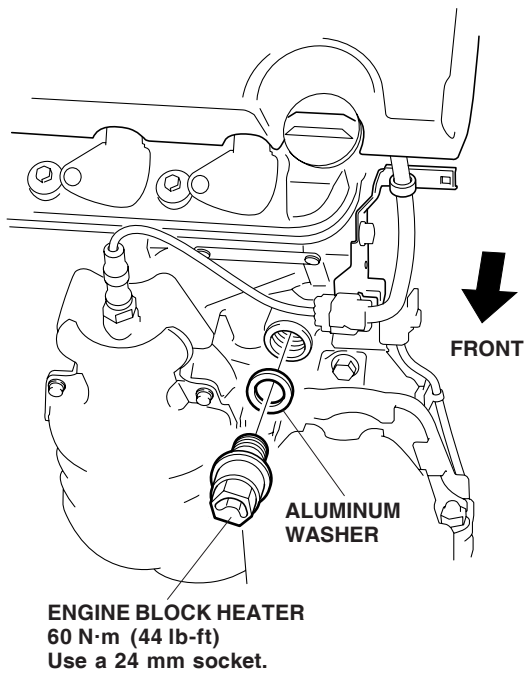

11. Using a white marker and a tape measure, mark the indicated position of the heater harness as shown.

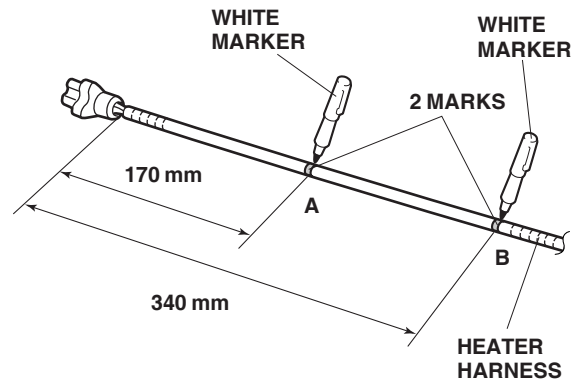

12. Pass the heater harness through the indicated hole on the lower grille as shown.

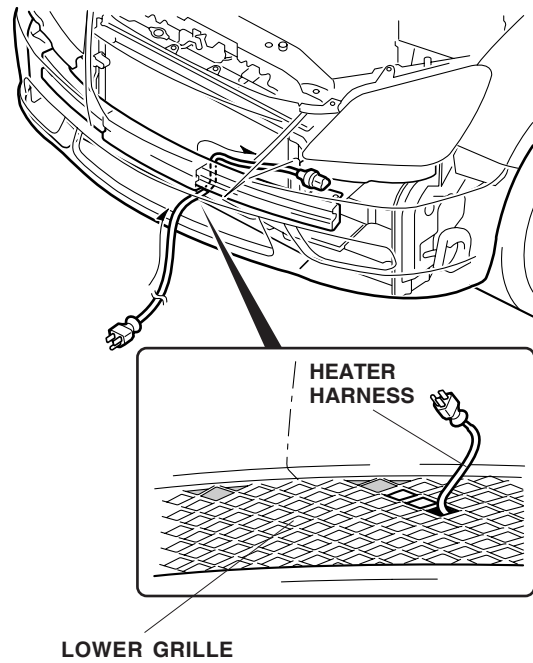

13. Route the heater harness towards the left headlight.

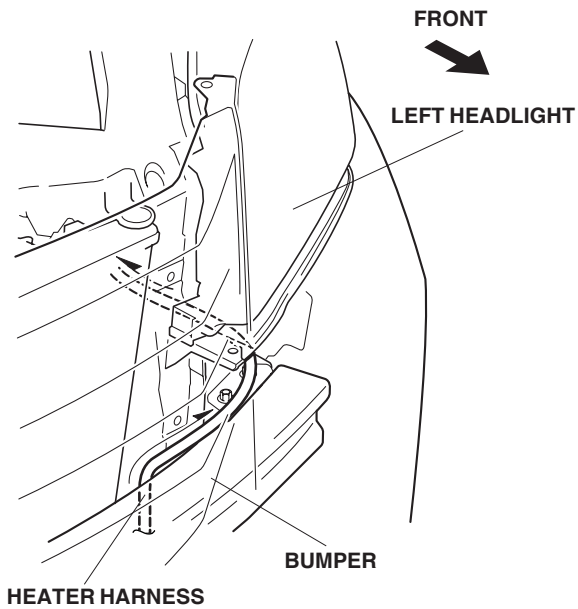

14. Route the heater harness along the vehicle harness.

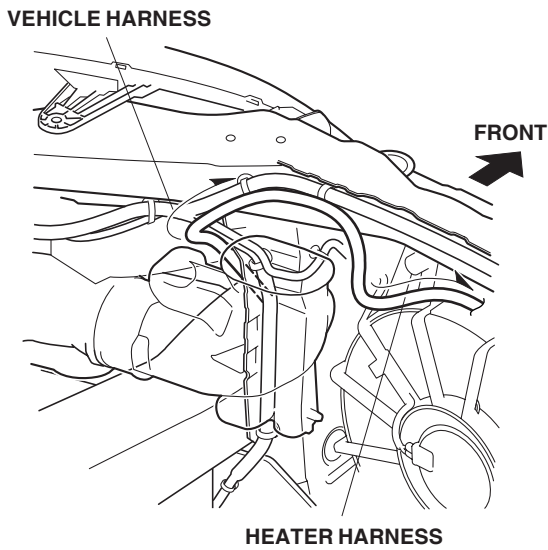

15. Route the heater harness along the fan shroud.

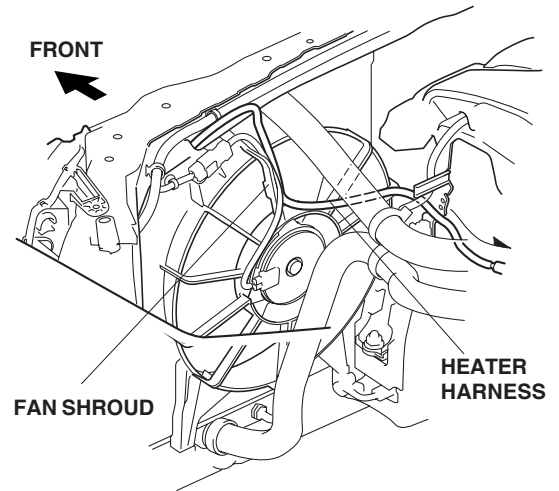

16. Plug the connector end of the heater harness into the engine block heater. Route the heater harness in the direction shown, and secure it to the vehicle bracket with a white wire tie (point A).

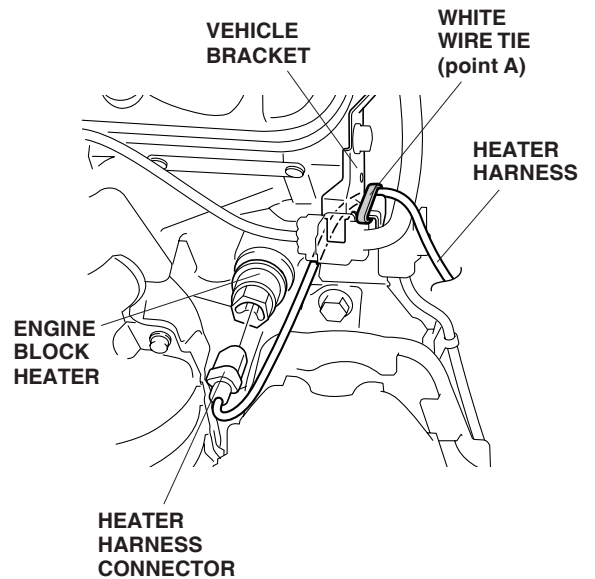

17. Secure the heater harness with one wire tie (point B).

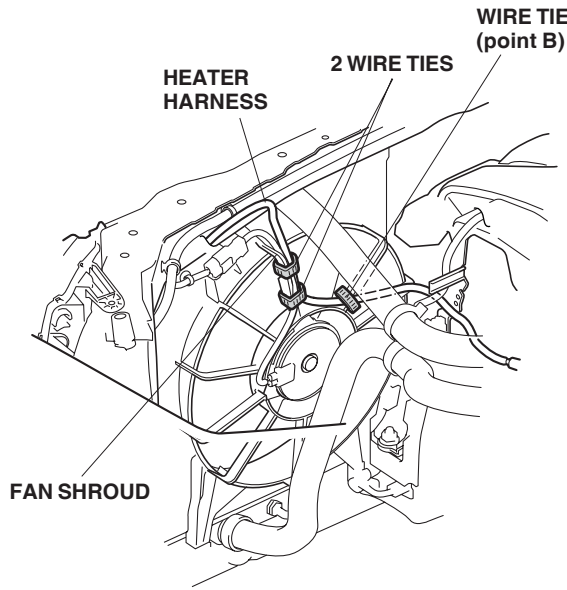

18. Secure the heater harness with two wire ties.  
 19. Secure the heater harness to the vehicle harness with three wire ties.

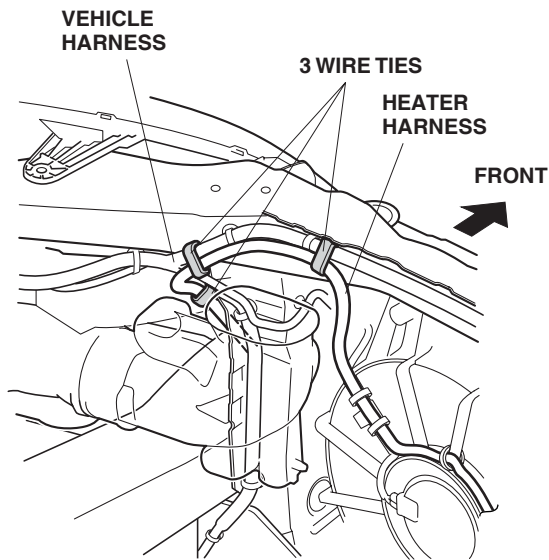

20. Secure the heater harness to the headlight bracket with one wire tie.

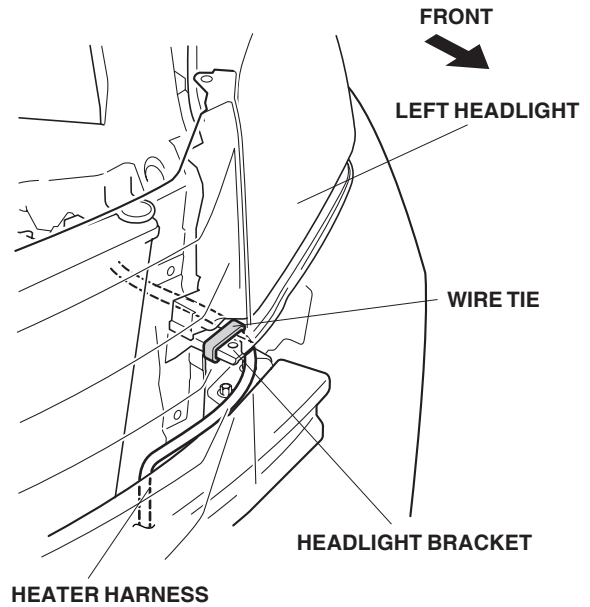

21. Route the heater harness along the front bumper beam, and secure the heater harness to the front bumper beam with four wire ties.

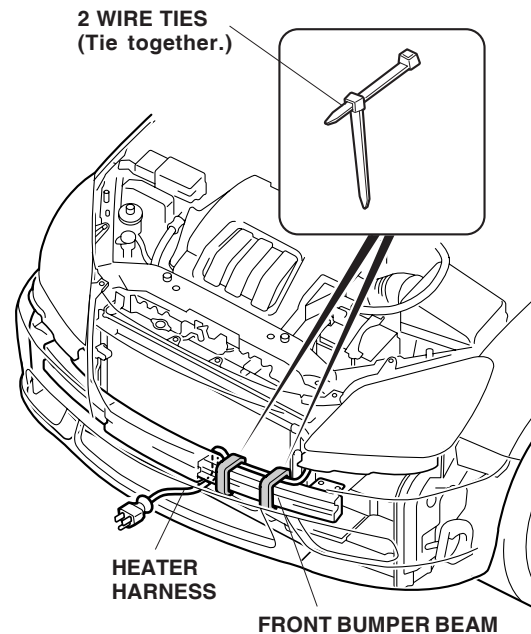

22. Attach the protective cap to the lower grille as shown, and plug the heater harness connector into the protective cap.

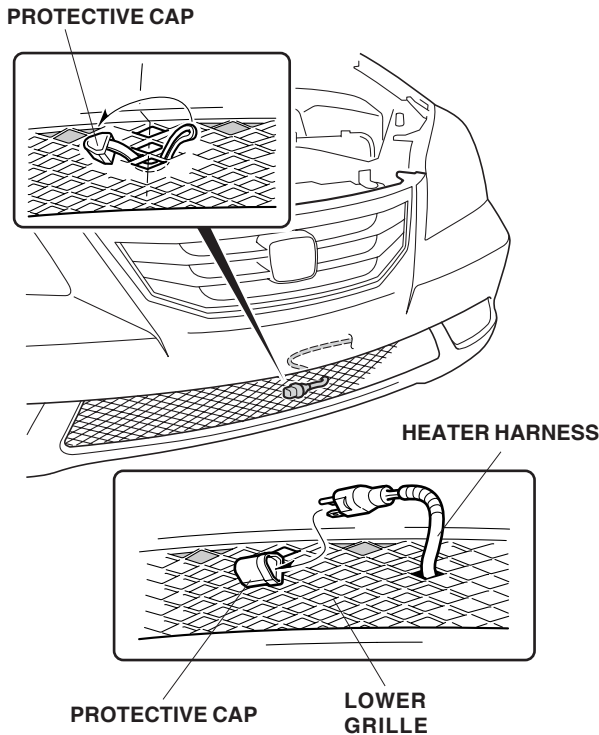

23. Secure the heater harness to the lower grille with a wire tie.

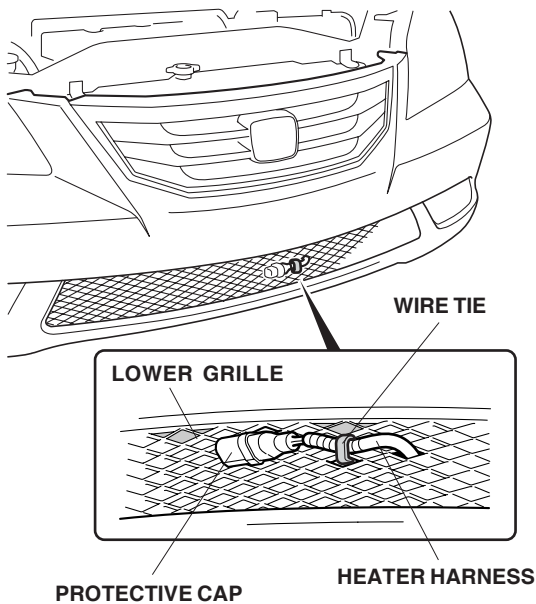

24. Reinstall the radiator drain plug.
25. Fill the system with the recommended coolant. Follow the instructions described in the service manual to fill and bleed the cooling system.
26. Check the coolant reservoir for correct level and check the cooling system for signs of leakage. Repair if necessary.
27. Check that the heater harness is routed properly and all connectors are plugged in.
28. Put the drain bolt (removed in step 9) in the glove box.

**NOTE:** When the battery is disconnected, the driver's window AUTO function is disabled.

- Start the engine. Push down on the driver's window switch until the window is fully open.
- Pull up on the driver's window switch to close the window completely, then hold the switch for 1 second or more.
- Lower and raise the driver's window to check operation of the driver's window AUTO function.



**With VCM2 Engine:**

29. Allow the engine and all cooling system components to cool down.
30. Place a clean drain pan under the radiator drain plug, then remove the drain plug from the bottom of the radiator to drain the coolant. Remove the radiator cap to increase the flow.

**NOTICE** Radiator coolant will damage the body paint. Quickly rinse any spilled coolant from the painted surfaces.

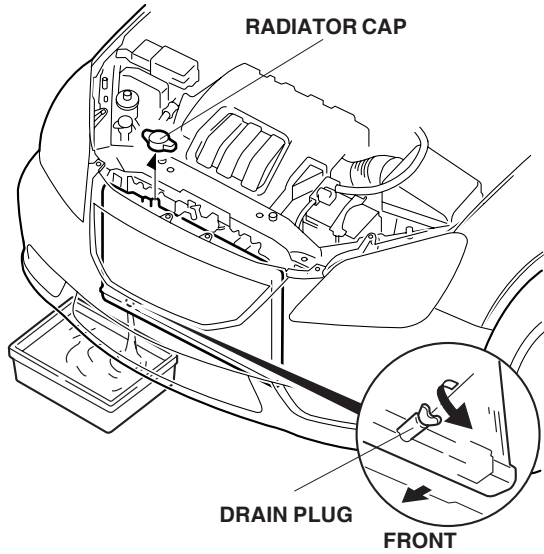

31. Remove the radiator cover (eight clips).

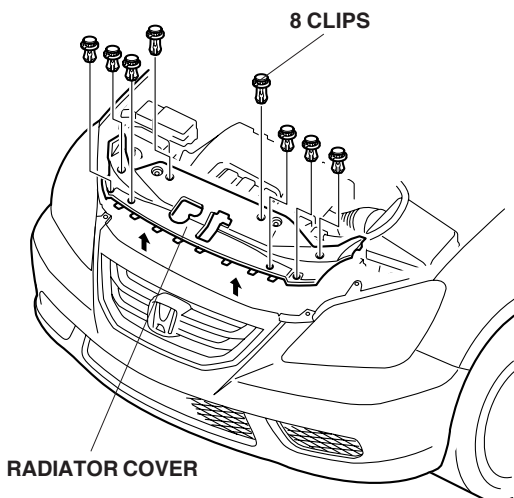

32. Take the cap off of the reservoir tank.

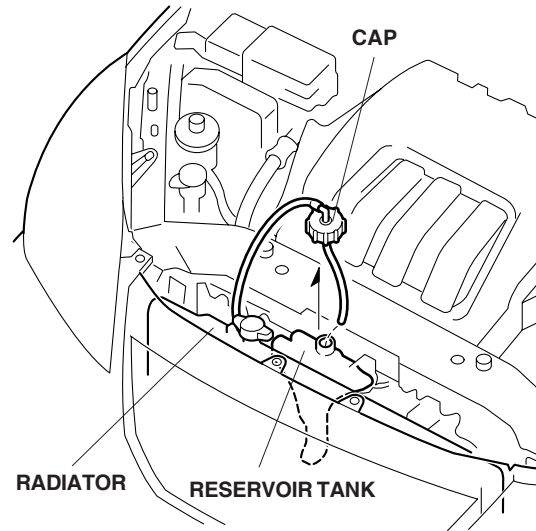

33. Remove two bolts from the reservoir tank.

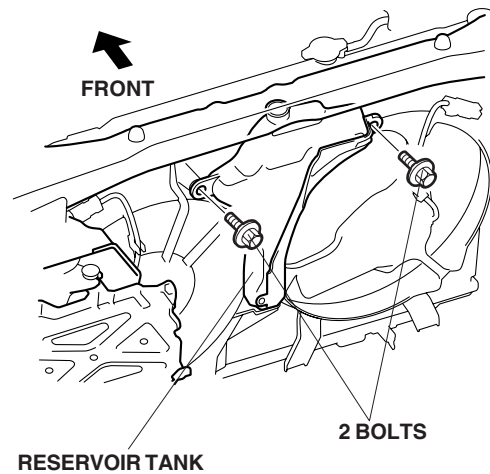



34. Remove the reservoir tank and the reservoir tank bracket (one tab).

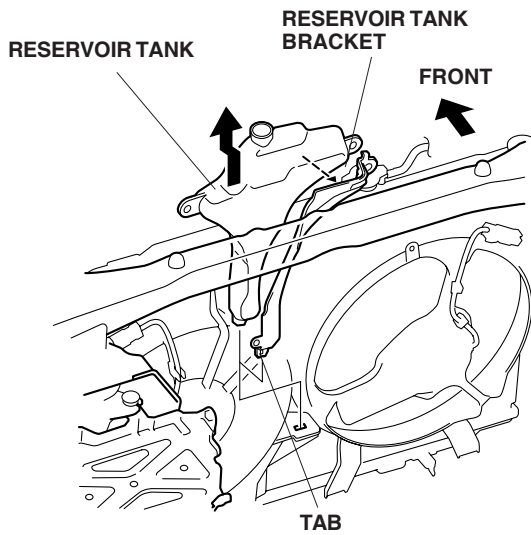

35. Remove two bolts from the radiator brackets, and remove the radiator brackets.

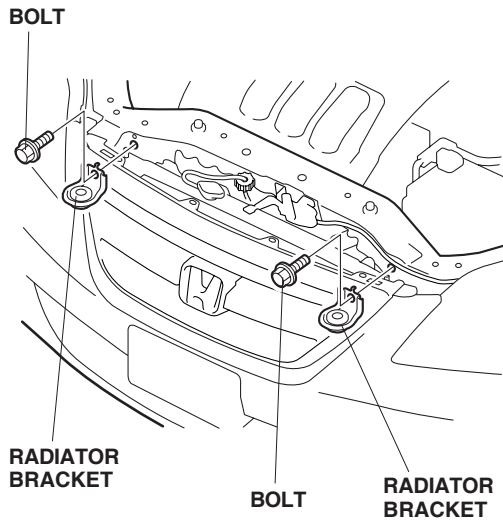

36. Remove the bolt from the lower oxygen sensor wire bracket, and move the bracket out of the way.

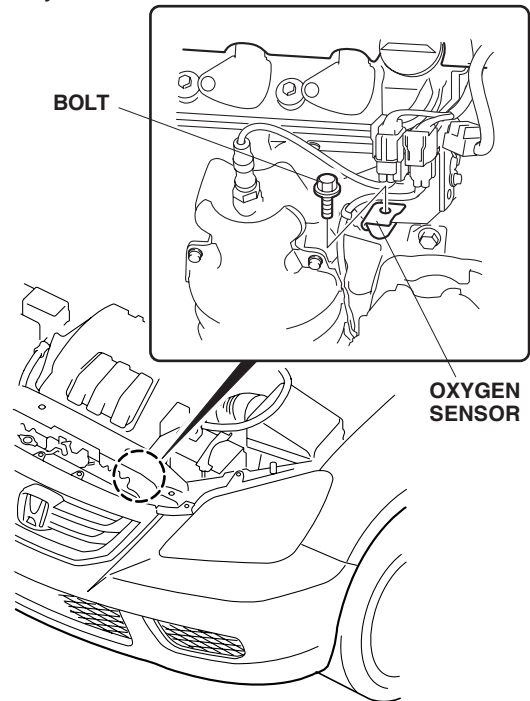

37. Locate and remove the drain bolt from the front of the block using a 19 mm socket. Coolant remaining in the engine jackets will flow out from the hole when the drain bolt is removed. (Retain the drain bolt, in case the engine block heater is removed.)

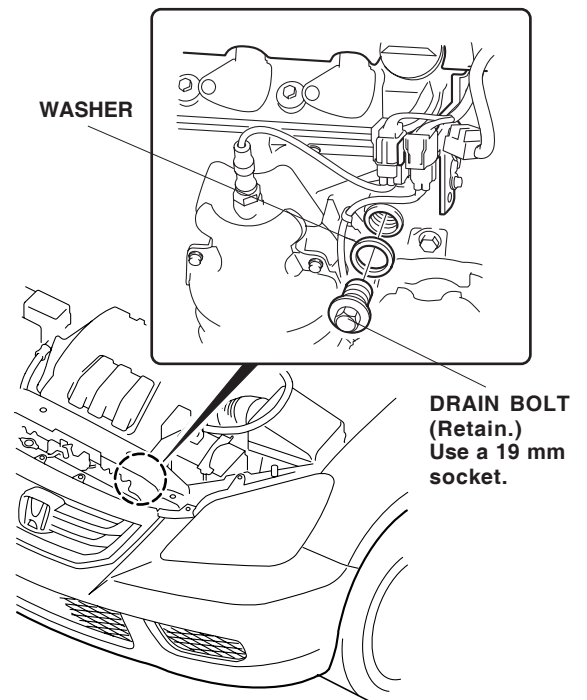

38. Install the engine block heater and the aluminum washer into the hole using a 24 mm socket. Torque the engine block heater to 60 N·m (44 lb-ft).

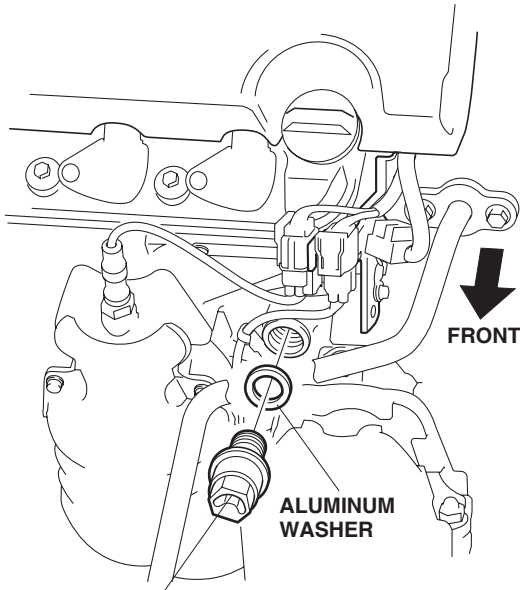

**ENGINE BLOCK HEATER**  
60 N·m (44 lb-ft)  
Use a 24 mm socket.

39. Using a tape measure, install one wire tie with clip to the heater harness and mark the indicated position using a white marker on the heater harness as shown.

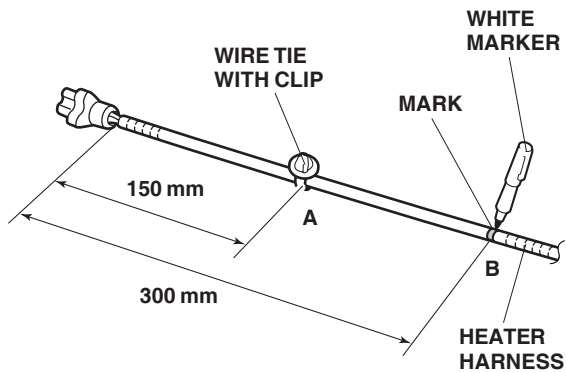

40. Pass the heater harness through the indicated hole on the lower grille as shown.

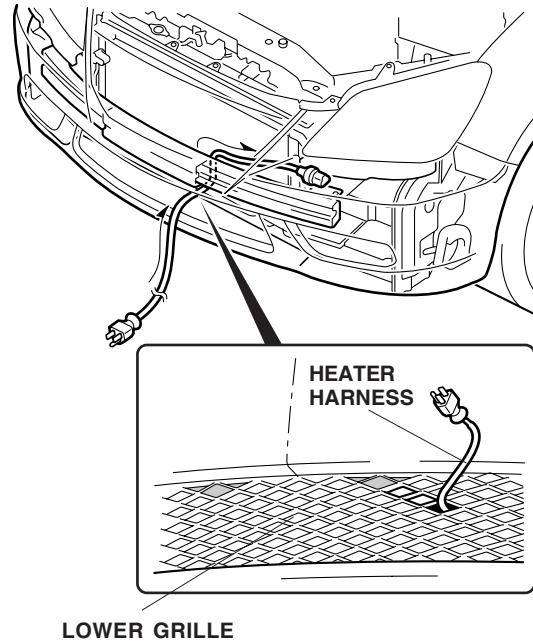

41. Route the heater harness toward the left headlight.

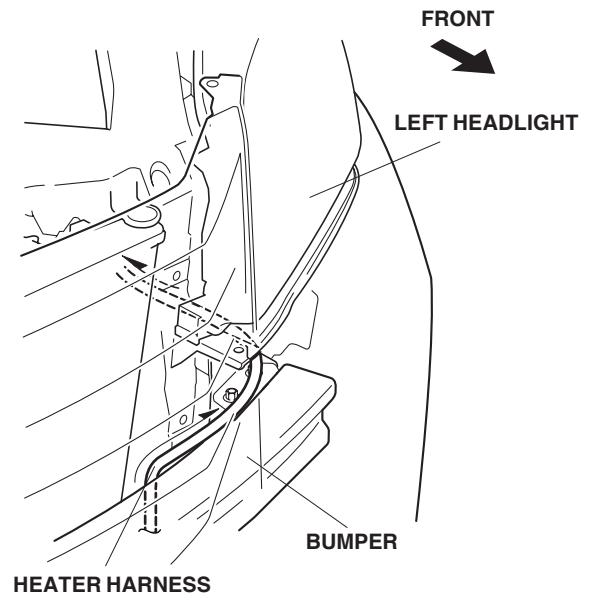

42. Route the heater harness along the vehicle harness.

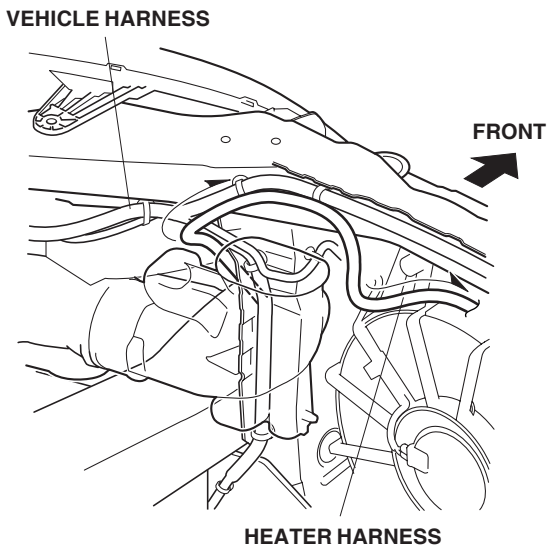

43. Route the heater harness along the fan shroud.

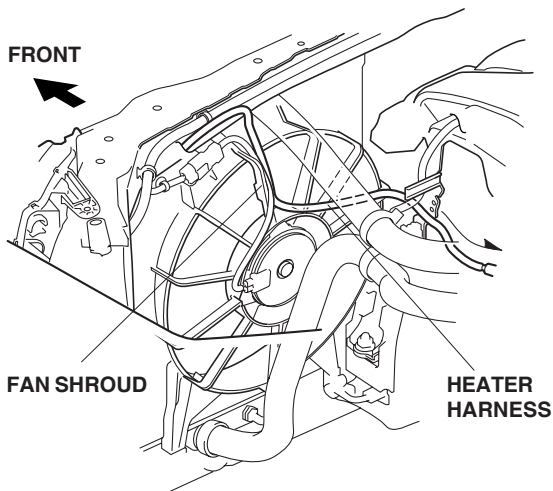

44. Plug the connector end of the heater harness into the engine block heater. Route the heater harness in the direction shown, and secure it to the vehicle bracket with a wire tie with clip (point A).

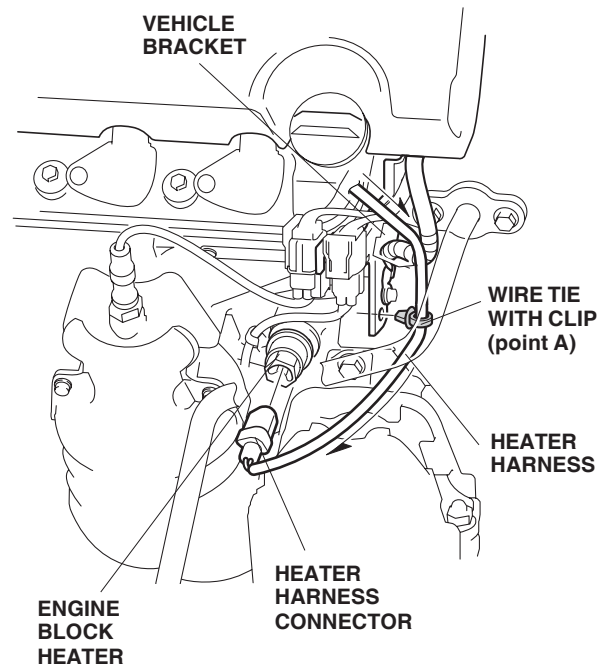

45. Secure the heater harness with one white wire tie (point B), and secure the heater harness with one white wire tie.

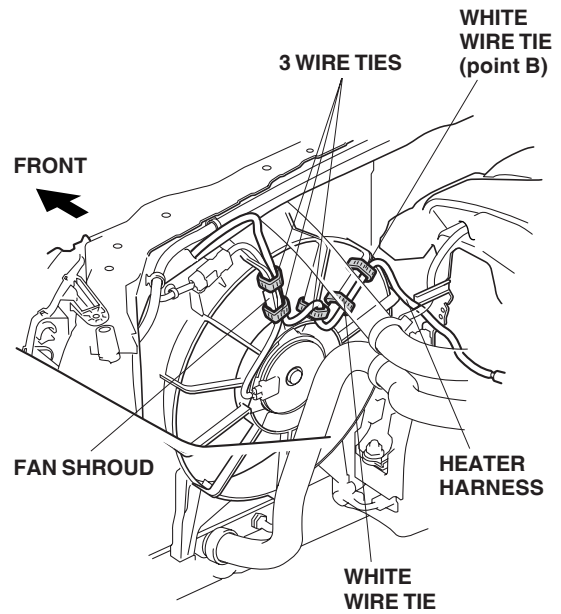

46. Secure the heater harness with three wire ties.

47. Secure the heater harness to the vehicle harness with three wire ties.

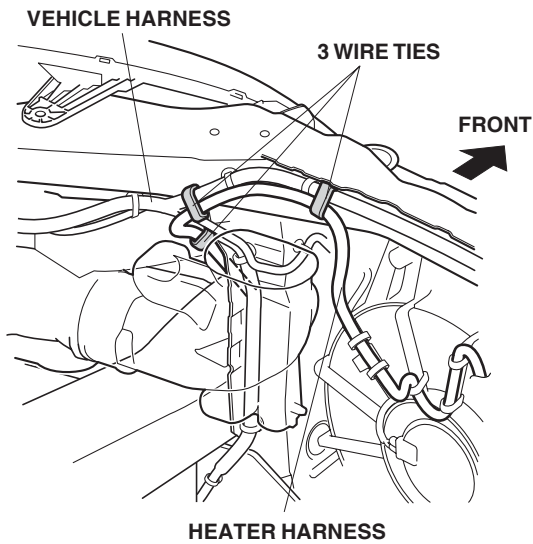

48. Secure the heater harness to the headlight bracket with one wire tie.

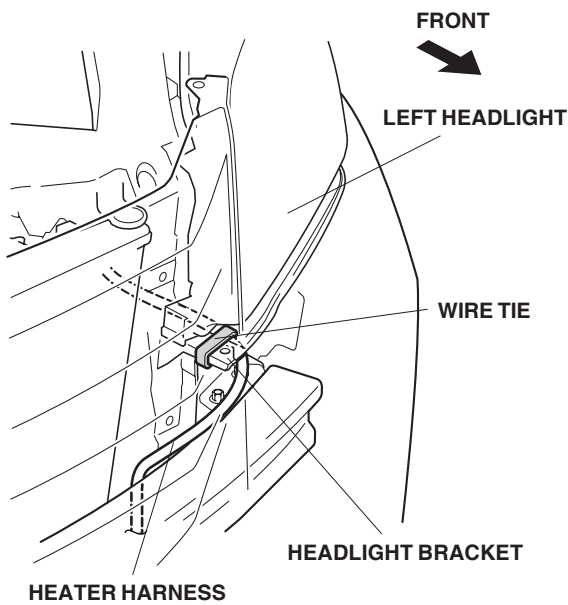

49. Route the heater harness along the front bumper beam, and secure the heater harness to the front bumper beam with four wire ties.

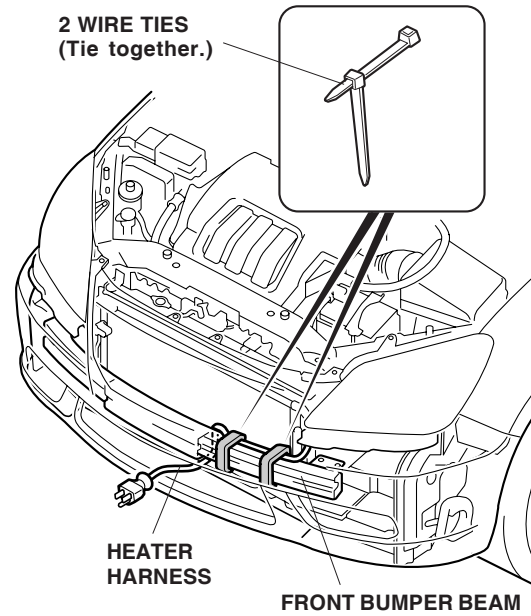

50. Attach the protective cap to the lower grille as shown, and plug the heater harness connector into the protective cap.

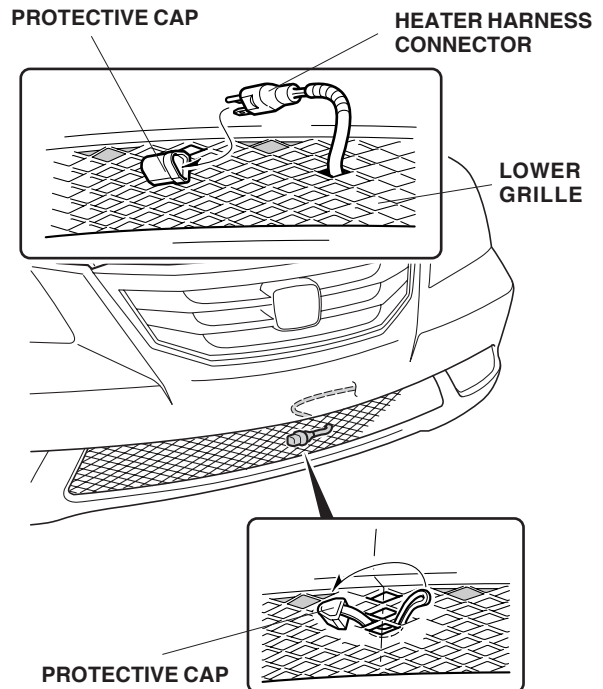

51. Secure the heater harness to the lower grille with one wire tie.

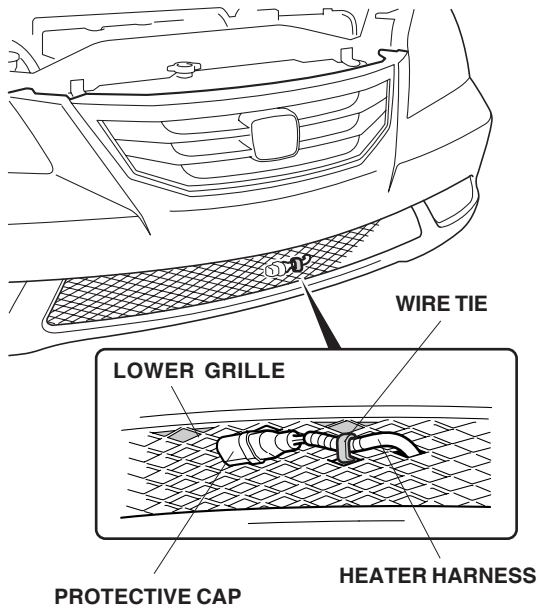

52. Reinstall the radiator drain plug.
53. Fill the system with the recommended coolant. Follow the instructions described in the service manual to fill and bleed the cooling system.
54. Check the coolant reservoir for correct level and check the cooling system for signs of leakage. Repair as necessary.
55. Check that the heater harness is routed properly and all connectors are plugged in.
56. Put the drain bolt (removed in step 37) in the glove box.

**NOTE:** When the battery is disconnected, the window driver's window AUTO function is disabled.

- Start the engine. Push down on the driver's window switch until the window is fully open.
- Pull up on the driver's window switch to close the window completely, then hold the switch for 1 second or more.
- Lower and raise the driver's window to check operation of the driver's window AUTO function.