



INSTALLATION INSTRUCTIONS

Accessory

**SPORT SUSPENSION
P/N 08W60-SNX-100**

Application

**2008 CIVIC
4-DOOR Si**

Publications No.

All 37921

Issue Date

OCT 2007

PARTS LIST

Right front damper assembly

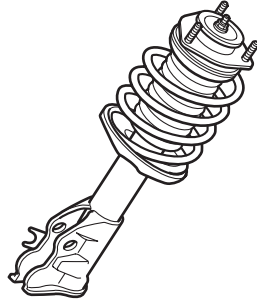

4 Flange bolts, 12 x 54 mm

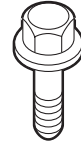

Left front damper assembly

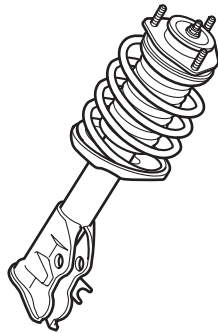

2 Flange bolts, 12 x 98 mm

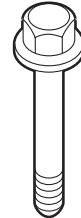

2 Rear dampers

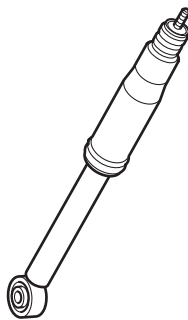

2 Flange bolts, 12 x 65 mm



4 Self-locking nuts, 14 mm



2 Self-locking nuts, 12 mm
(not used)



2 Self-locking nuts, 10 mm



2 Rear springs

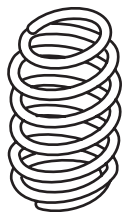

Important information

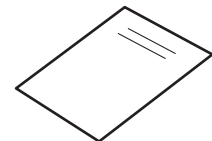

4 Flange bolts, 14 x 57 mm



TOOLS AND SUPPLIES REQUIRED

10 mm and 12 mm Combination wrenches
17 mm and 19 mm Sockets
Ratchet
Torque wrench
KTC trim tool set (SOJATP2014)
5 mm Hex wrench
Needle-nose pliers
Floor jack

INSTALLATION

Customer Information: The information in this installation instruction is intended for use only by skilled technicians who have the proper tools, equipment, and training to correctly and safely add equipment to your vehicle. These procedures should not be attempted by "do-it-yourselfers."

NOTE:

- Inflate the tires to the specified air pressure.
- The dampers for the left and right sides are different. The damper marked R goes on the right side; the damper marked L goes on the left side.
- These dampers are designed to be used exclusively with this model and should not be used with other models.
- These instructions show the left damper assembly being installed; the same procedure applies to installing the right damper assembly.

Removing the Front Damper

1. With the vehicle on a rack, remove all four wheels.
2. Remove the wheel sensor harness clip and the brake hose bracket from the damper. Do not disconnect the wheel sensor connector.

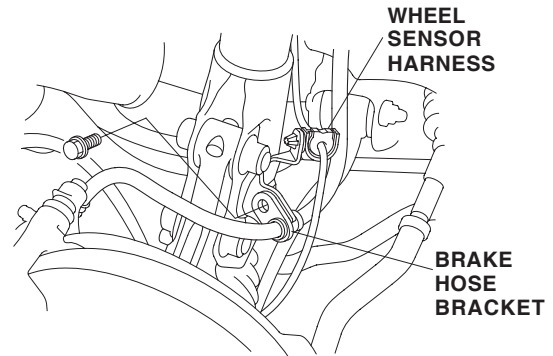

3. Remove the damper pinch bolts and self-locking nuts from the damper. Do not allow the knuckle to rotate too far outward. This may allow the inner CV joint bearing to unseat.

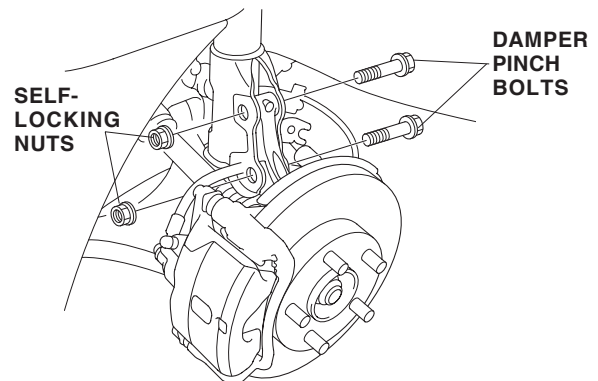

- Turn the ignition switch ON (II), then turn on the wipers. Turn the ignition switch off when the wipers are near the A-pillars.
- Remove the service cap and the lid.

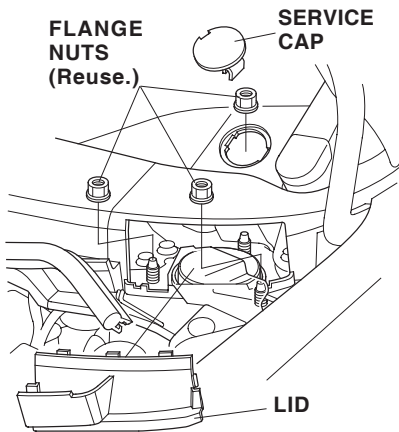

- Remove the three flange nuts from top of the damper.
- Remove the damper assembly. Be careful not to damage the body.

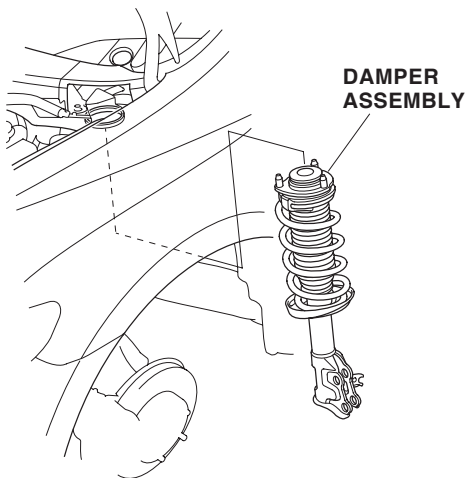

Installing the Front Damper

- Install the new left front damper assembly onto the frame.

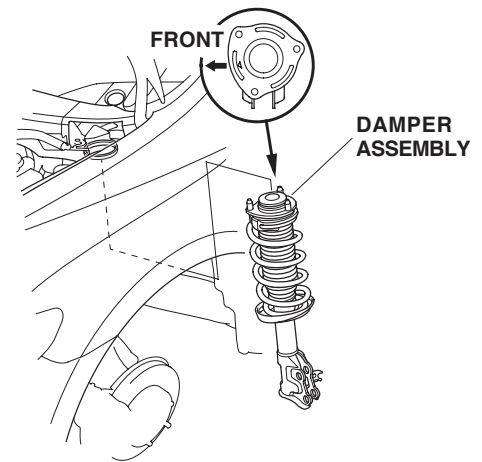

- Loosely install the flange nuts you removed in step 6.

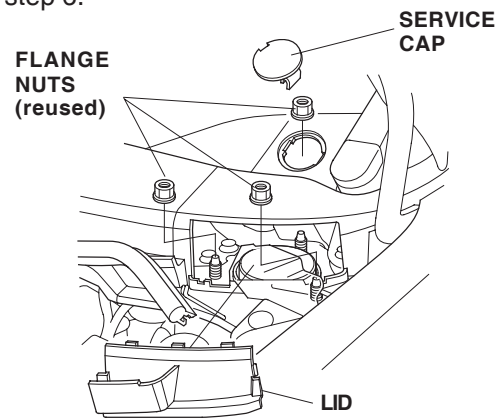

10. Loosely install new damper pinch bolts and new self-locking nuts to the damper.

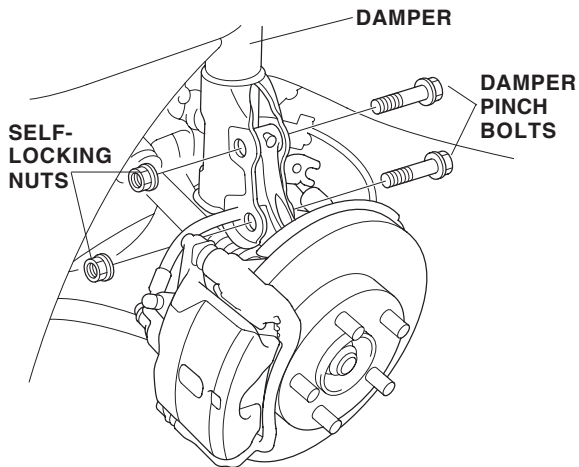

11. Install the wheel sensor harness clip and the brake hose bracket to the damper.

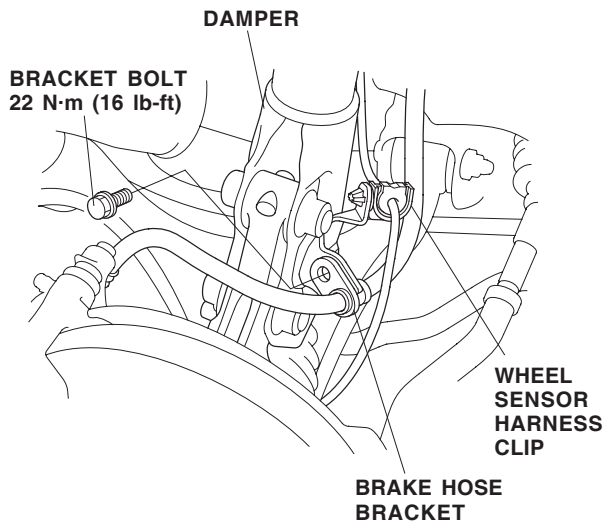

12. With the suspension loaded with the weight of the vehicle, torque the damper pinch bolts and the self-locking nuts to 90 N·m (67 lb-ft), and torque the upper flange nuts to 59 N·m (43 lb-ft).
13. Repeat steps 2 thru 12 to install the right front.
14. Install the service cap and the lid.
15. Reinstall the front wheels.

Removing the Rear Damper

16. Lower the vehicle near the ground.
17. Remove the trunk side trim panel.
- Fold each rear seat-back forward.
 - Pull back the front portion of the spare tire lid and detach the clips.

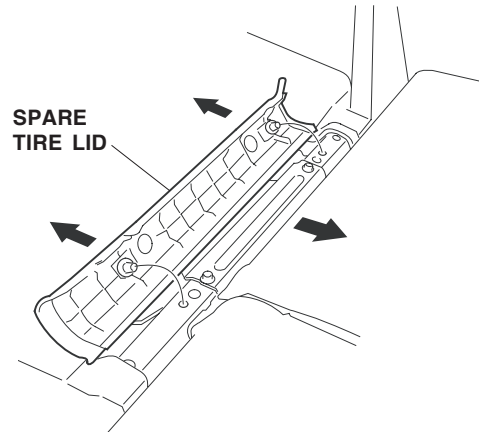

- Remove the spare tire lid.

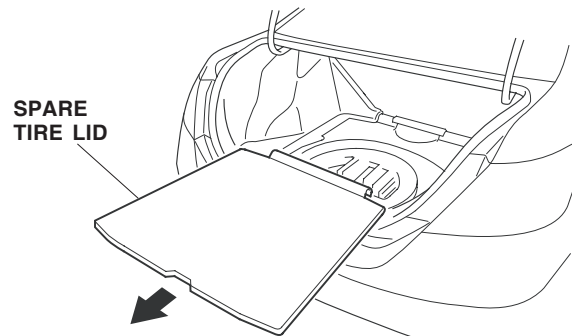

- Remove the trunk lip weatherstrip near the trunk rear trim panel. Detach the clips, and release the hooks by pulling the trunk rear trim panel up, and then remove it.

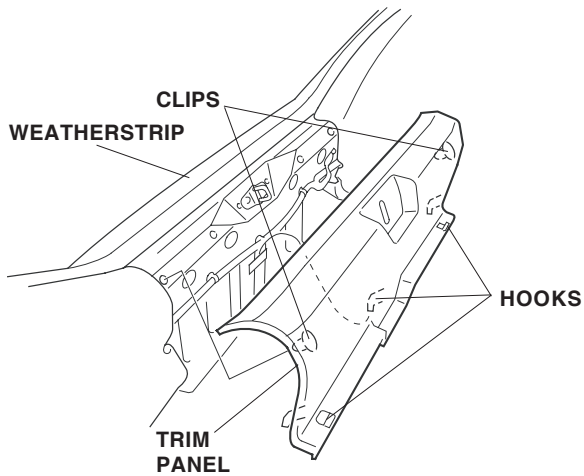

- Remove the clips, and then remove the left trunk side trim panel from the trunk. Release the rear seat-back release cable out through the slit in the trim panel.

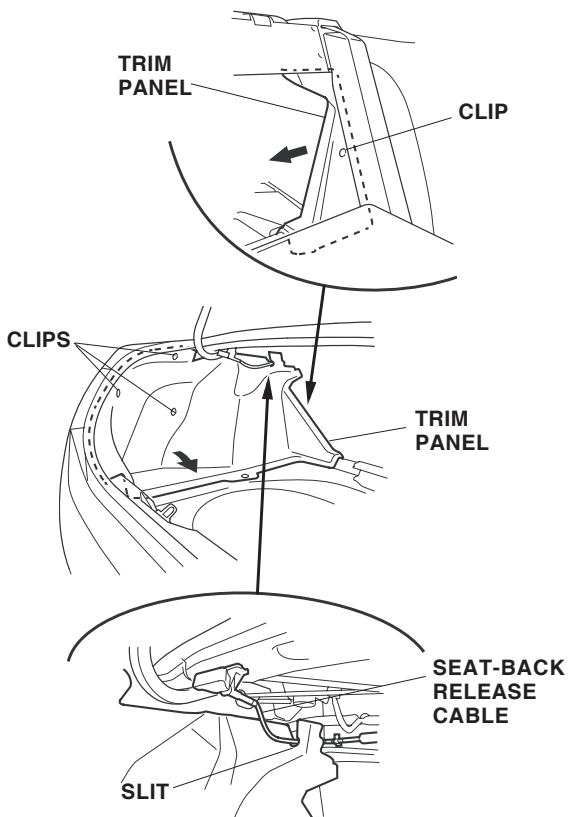

- Remove the right trunk side trim panel the same way.

- Position the floor jack at the connecting point of the trailing arm and the knuckle. Raise the floor jack until the suspension begins to compress. Remove the flange bolt from the bottom of the damper.

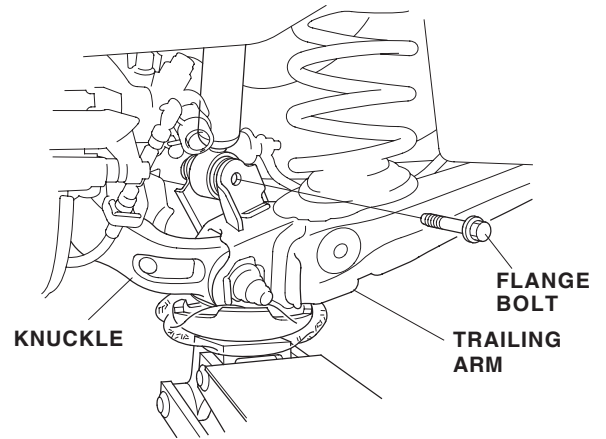

- Remove the wheel sensor and O-ring from the knuckle. Do not disconnect the wheel sensor connector.

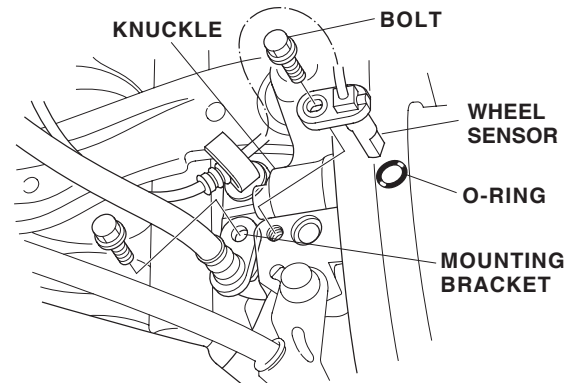

- Remove the brake hose mounting bracket. Using needle nose pliers, disconnect the wheel sensor clip from the brake hose mounting bracket.

21. Remove the self-locking nut and the flange nut while holding the joint pin with a hex wrench, and then remove the stabilizer link.

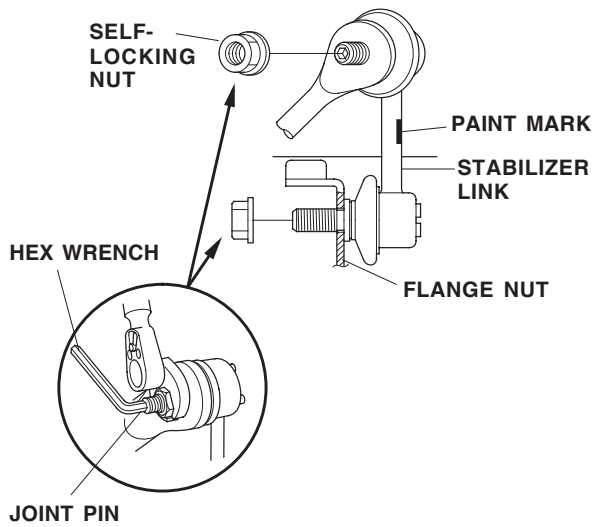

22. Remove the flange bolt that connects the knuckle and the upper arm.

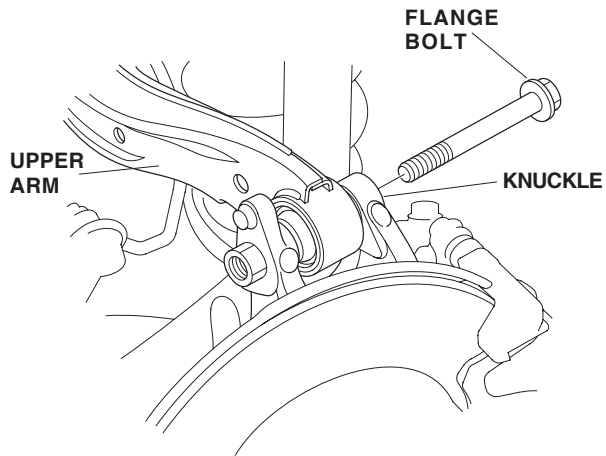

23. Remove the trailing arm front mounting bolts.

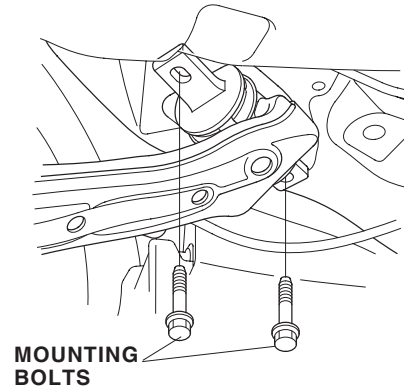

24. Remove the self-locking nut while holding the damper shaft with a hex wrench.

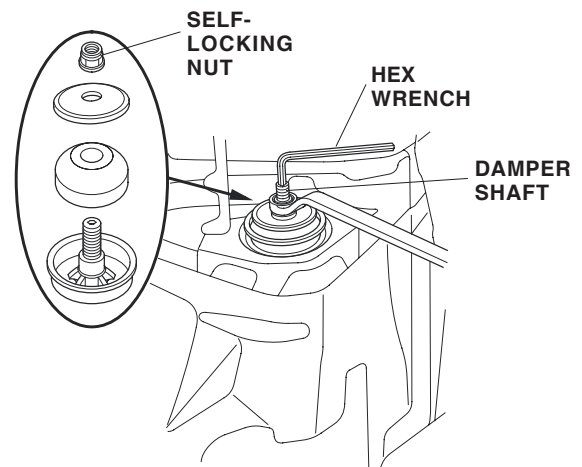

25. Compress the damper unit by hand, and remove it from the vehicle.

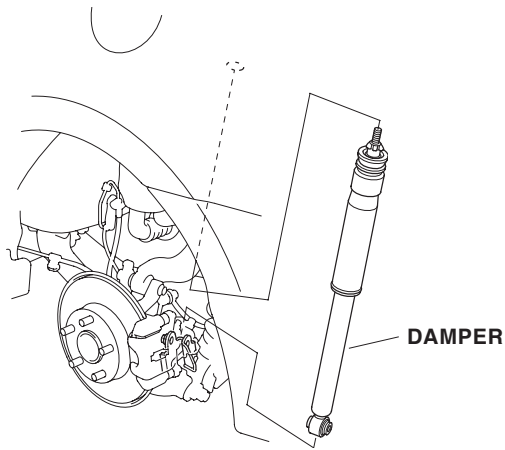

26. Lower the floor jack gradually.
27. First remove the spring mounting rubber, and then remove the spring and lower spring seat.

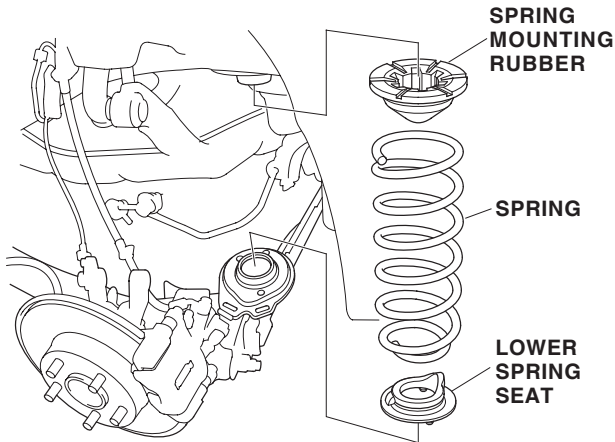

Installing the Rear Damper and Spring

28. Install the spring mounting rubber, the new spring, and the lower spring seat.

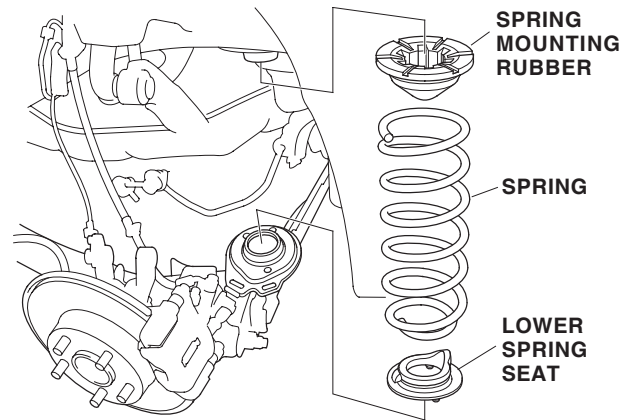

29. Align the bottom of the spring and the lower spring seat with the trailing arm as shown.

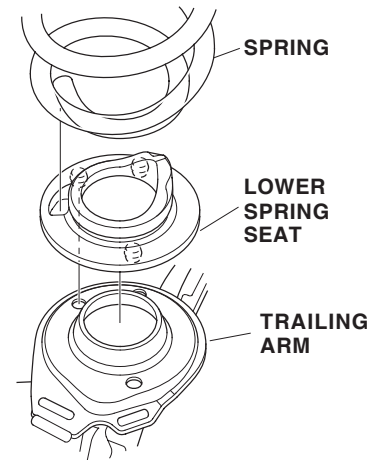

30. Loosely install the new trailing arm front mounting bolts.

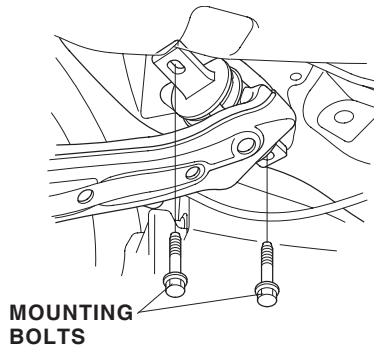

31. Loosely install a new flange bolt on the knuckle and the upper arm.

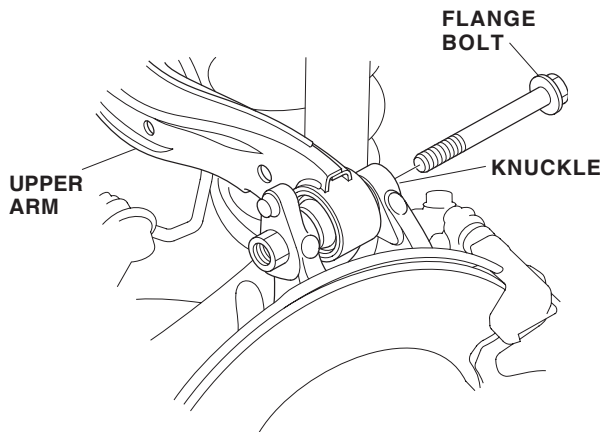

32. Install the damper mounting bushing onto the damper unit, and install the damper unit. Slowly raise the jack until you can align the bolt hole with the holes in the trailing arm and the damper, and then install the new flange bolt.

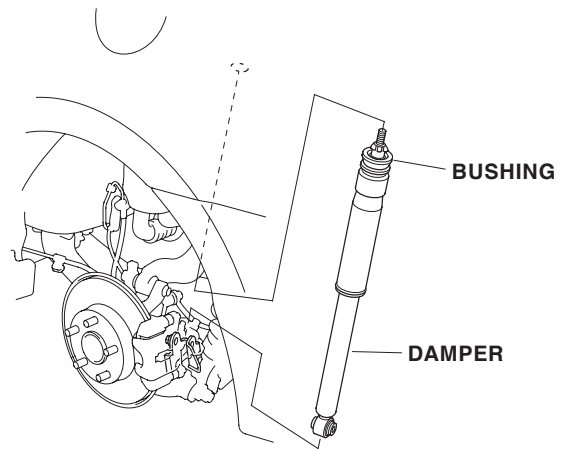

33. Install the stabilizer link on the stabilizer bar and trailing arm with the joint pins set at the center of their range of the movement.

NOTE: The stabilizer link has a paint mark. Align the paint mark on the stabilizer link facing rearward.

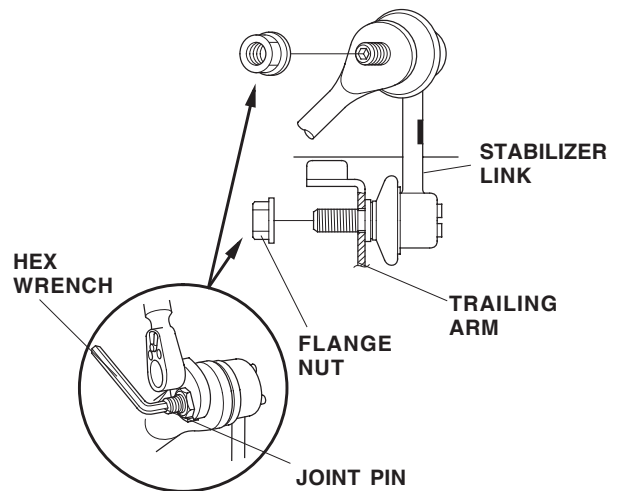

34. Install the stabilizer link on the trailing arm with a new self-locking nut, and lightly tighten both nuts.

35. Install the damper mounting bushing, the damper mounting washer, and a new self-locking nut on the damper shaft.

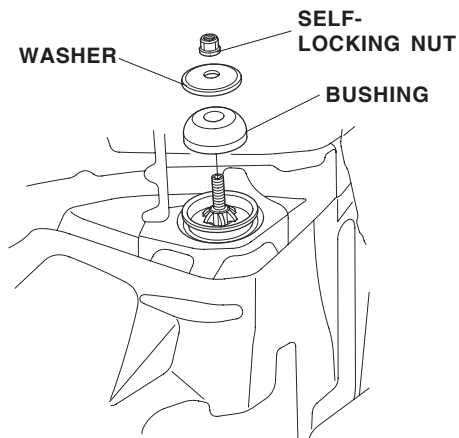

36. Torque the damper shaft self-locking nut to 29 N·m (21 lb-ft) while holding the damper shaft with a hex wrench.

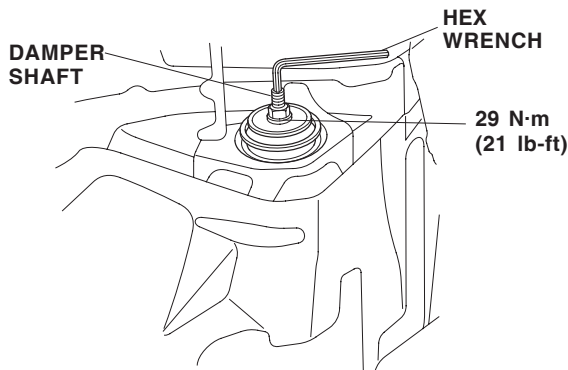

37. Raise the rear suspension with the floor jack to load the vehicle weight.

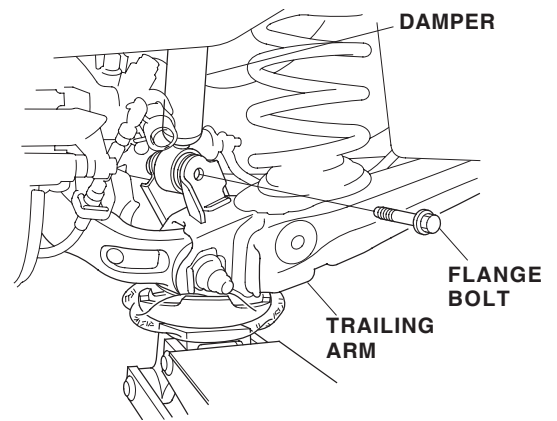

38. Torque the trailing arm bolts to 108 N·m (80 lb-ft).
39. Torque the flange bolt to 59 N·m (44 lb-ft).
40. Torque the damper flange bolt to 69 N·m (51 lb-ft).
41. Torque the stabilizer link to 39 N·m (29 lb-ft).
42. Repeat steps 17 thru 41 to install the right damper and spring.
43. Reinstall the trunk side trim panel.
44. Install the brake hose mounting bracket and torque to 22 N·m (16 lb-ft). Reinstall the wheel sensor, and torque the bolt to 10 N·m (7 lb-ft).
45. Reinstall the wheels, and torque the wheel nuts to 108 N·m (80 lb-ft).

WHEEL ALIGNMENT SPECIFICATIONS:

NOTE: This alignment specification is only applied to vehicles with a Honda Accessory Sport Suspension.

'08 M	Sport Suspension				
		CAMBER (NEGATIVE)		TOE	
Civic 4-door Si (KA)	Front	0°	±30'	0 mm	±2 mm
	Rear	-2°	±1°	IN 2 mm	+2 -1 mm