



INSTALLATION INSTRUCTIONS

Accessory	Application	Publications No.
REAR UNDER SPOILER	2008 CIVIC HYBRID	All 37975
		Issue Date
		OCT 2007

PARTS LIST

Rear under spoiler

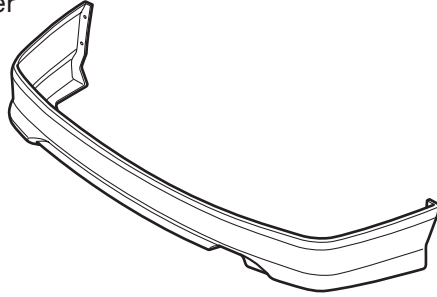

2 Step bolts



4 Self-tapping screws

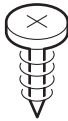

2 Spring nuts



4 Flange bolts



6 Flange nuts



Spacer

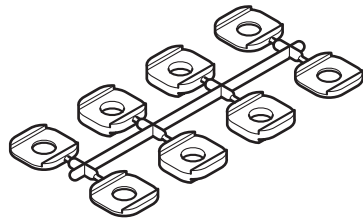

Template

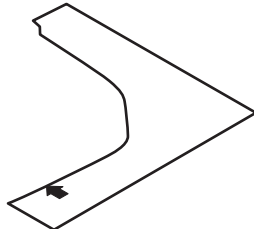

TOOLS REQUIRED

Phillips screwdriver

Hex wrench

Drill

3 mm and 10 mm Drill bits

Clip remover

Pushpin

Felt-tip pen

Tape measure

Masking tape

Touch-up paint

File

Diagonal cutters

Isopropyl alcohol

Shop towel

Eye protection

INSTALLATION

Customer Information: The information in this installation instruction is intended for use only by skilled technicians who have the proper tools, equipment, and training to correctly and safely add equipment to your vehicle. These procedures should not be attempted by "do-it-yourselfers."

NOTE:

- Be careful not to damage the rear bumper and body paint finish.
- This rear under spoiler kit should be installed only if the ambient air temperature is 60°F (15°C) or above.
- To allow the adhesive to cure, do not wash the vehicle for 24 hours.

1. Position the template on the rear bumper and mark the bumper by applying masking tape as indicated on the template. Note the installation direction of the template.

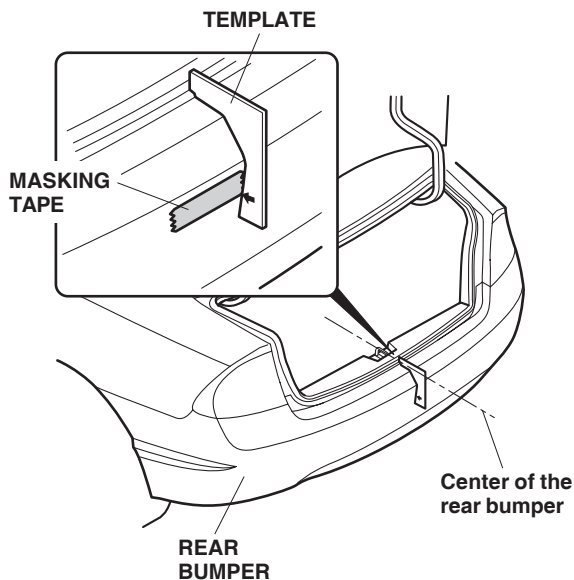

If the vehicle is equipped with rear inner fenders, go to step 5; if not, go to step 2.

2. While wearing eye protection, drill a 3 mm hole through the center of the four dimples on the rear bumper. Remove any burrs from the edges of the holes with a file.

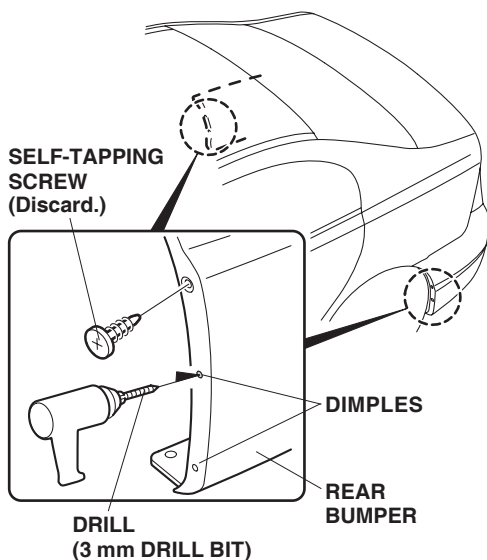

3. Remove and discard the two self-tapping screws from the fenderwell area of the rear bumper.

4. Slide spring nuts over the two upper holes you made in the rear bumper.

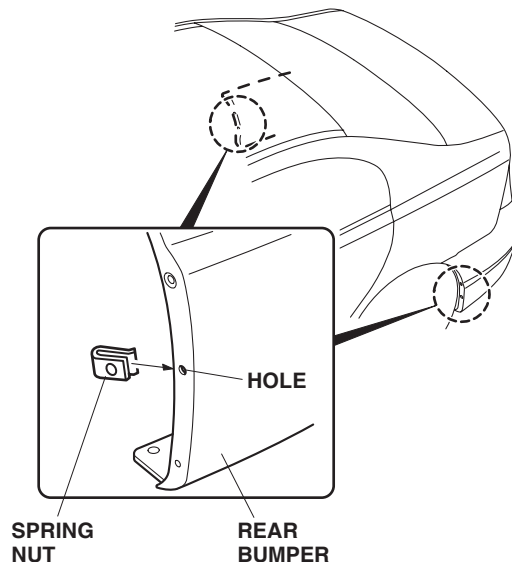

5. Attach a strip of masking tape to the end of each adhesive backing, and peel back 1-1/2 to 2 inches of the adhesive backing. Fold the ends back, and tape them to the front of the rear under spoiler.

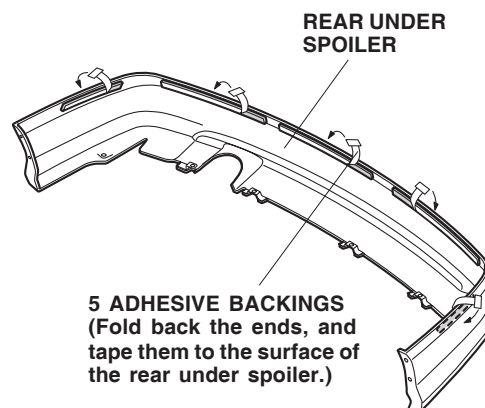

6. Using isopropyl alcohol on a shop towel, clean the rear bumper where the rear under spoiler will attach.

7. Align the top edge of the rear under spoiler with the edge of the masking tape you attached, then secure the rear under spoiler to the rear bumper with four self-tapping screws. Do not tighten the self-tapping screws yet. Make sure to position the corners of the under spoiler to eliminate any gaps between the rear bumper and under spoiler.

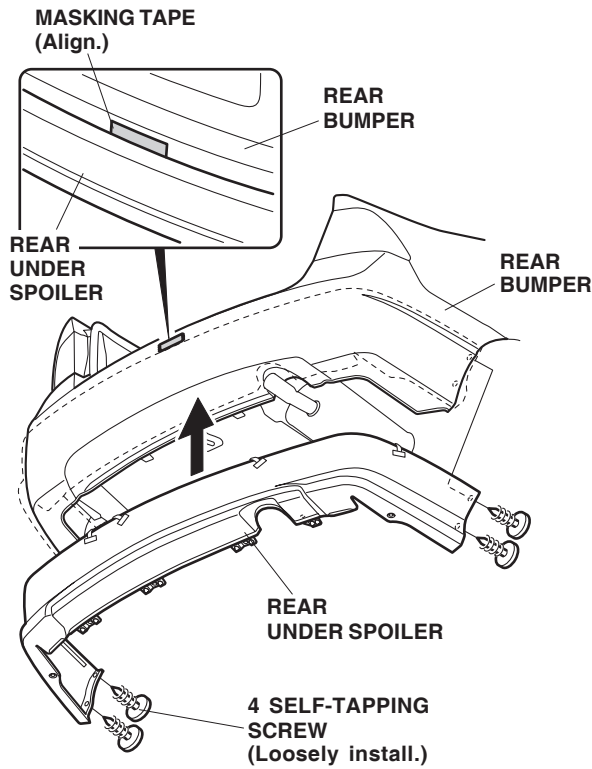

8. While applying pressure to the rear under spoiler, use a felt-tip pen to mark the rear bumper at each hole in the bracket on the rear under spoiler.

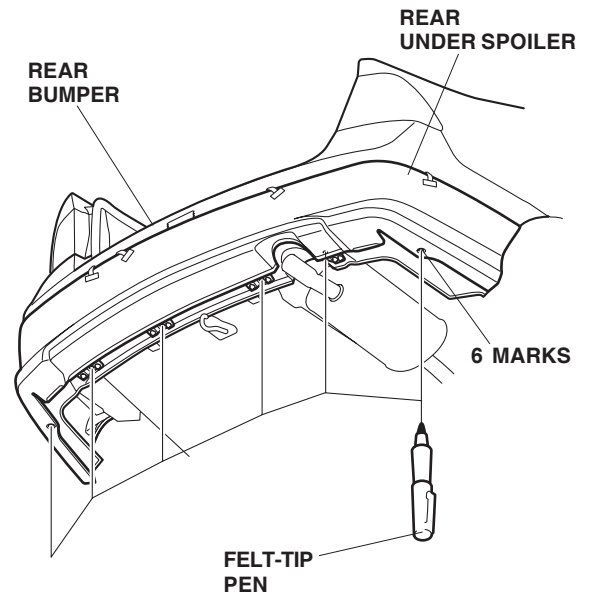

NOTE: If a gap is visible between the rear bumper and under spoiler, remove the under spoiler and confirm the locations of the marks with a tape measure. If necessary, create new marks in the proper locations.

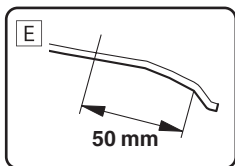
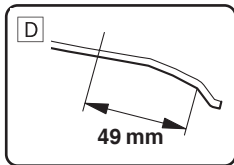
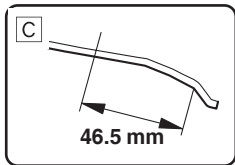
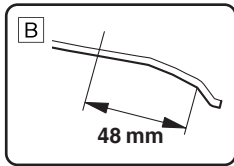
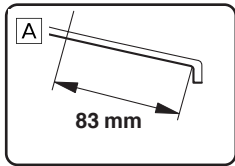
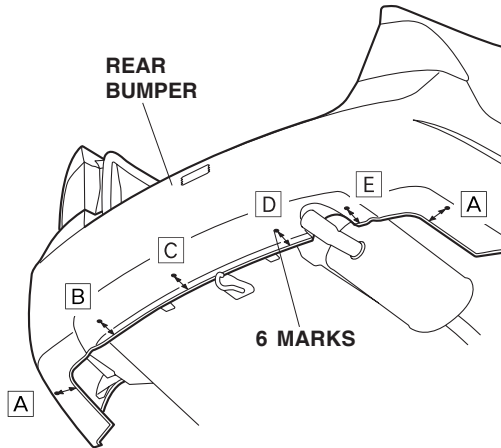

9. Using a pushpin, make a hole through each marked location on the rear bumper.

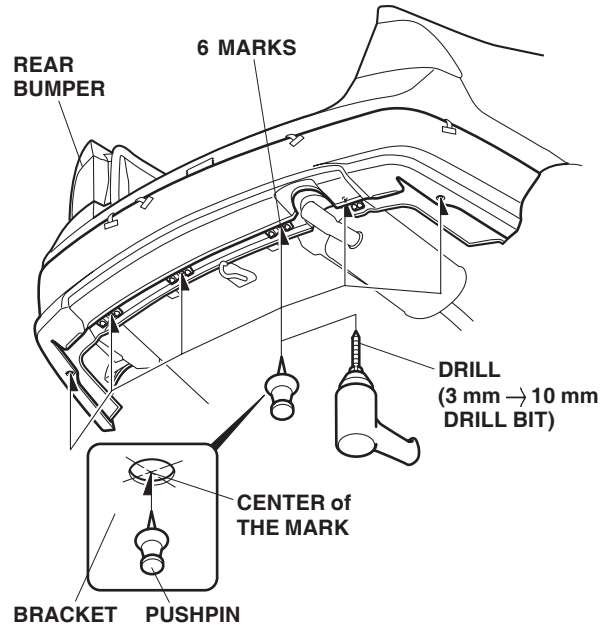

10. While wearing eye protection, drill a 10 mm hole through each marked location on the rear bumper. First drill with a 3 mm bit, then finish with a 10 mm bit. Remove any burrs from the edges of the holes with a file. Apply touch-up paint as necessary.

11. Remove the clips from the bottom of the rear bumper to access the center flange nut.

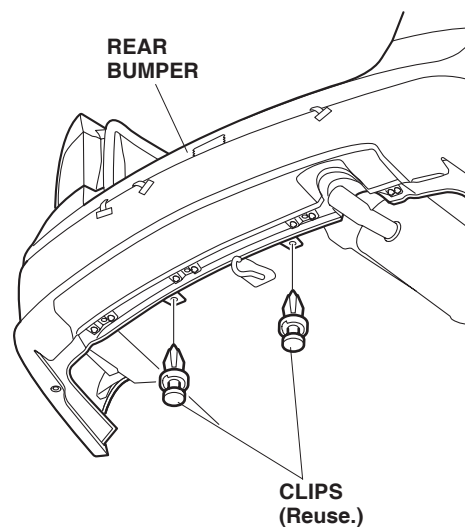

12. Install the rear under spoiler with two step bolts, four flange bolts, and six flange nuts.

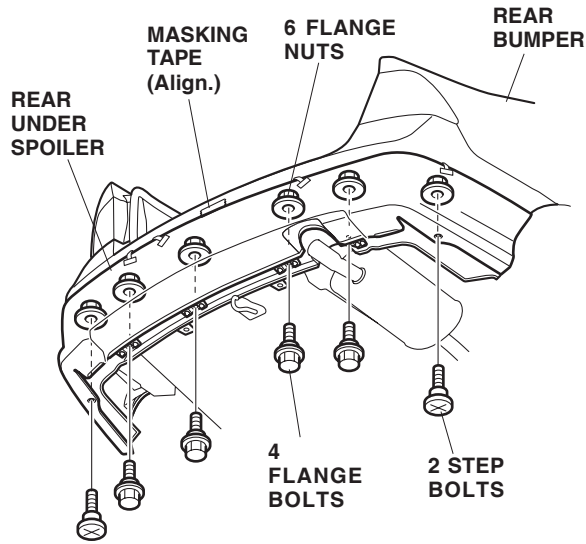

13. Check that the top edge of the rear under spoiler aligns with the lower edge of the masking tape you attached in step 1, and remove the masking tape.

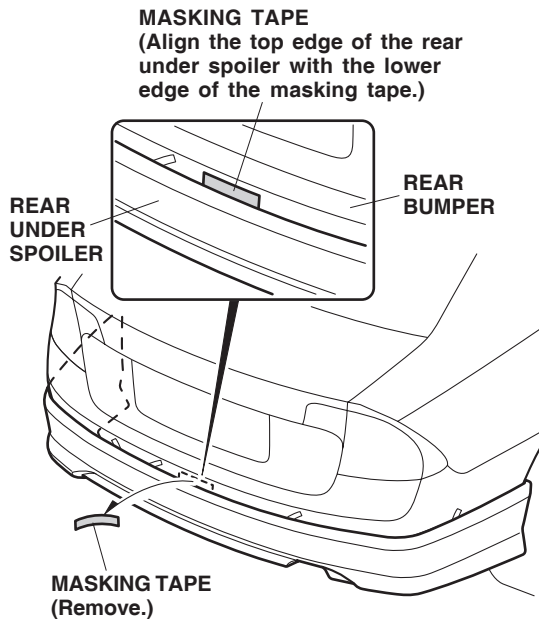

14. While applying pressure on the rear under spoiler, carefully remove the adhesive backings in the sequence shown. After removing, hold the rear under spoiler firmly against the rear bumper with the palm of your hand for 30 seconds.

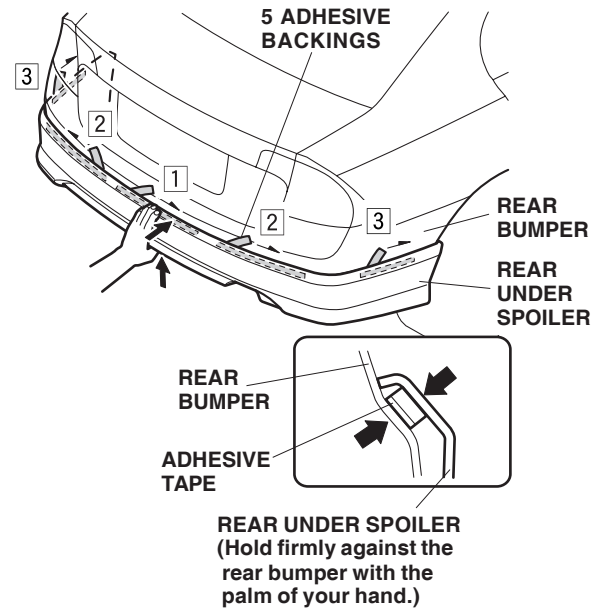

15. Tighten the self-tapping screws you installed in step 7. If there is a gap, use one (or two) spacer(s) between the rear bumper and the rear under spoiler to prevent excess gaps.
- Using diagonal cutters, cut the spacers apart.
 - Spacer thickness of "1" and "2" represent 1 mm and 2 mm respectively.
 - Do not combine two "2" spacers together. This creates too large a gap.

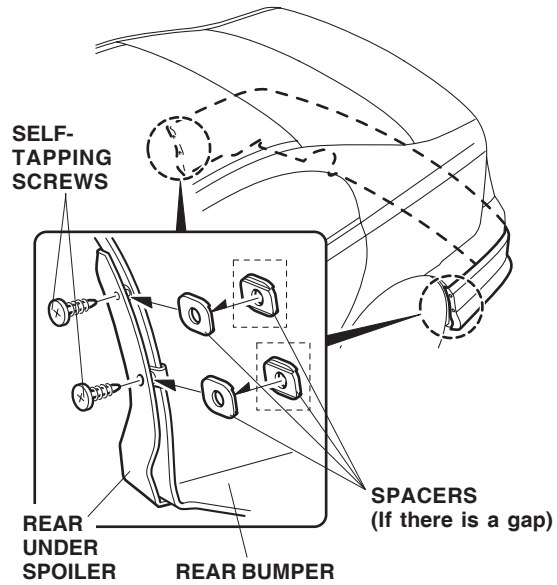

16. Reinstall all removed parts.