



INSTALLATION INSTRUCTIONS

Accessory

ENGINE BLOCK HEATER
P/N 08T44-SVB-100

Application

2008 CIVIC HYBRID

Publications No.

All 37964

Issue Date

SEP 2007

PARTS LIST

Engine block heater

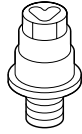

Aluminium washer



Heater harness



Protective cap

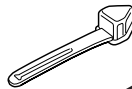

15 Black wire ties
(4 not used)

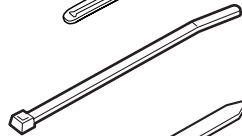

3 Wire ties with clips
(1 not used)

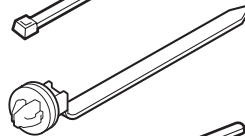

5 White wire ties
(3 not used)



TOOLS AND SUPPLIES REQUIRED

Ratchet

10 mm, 19 mm and 24 mm Sockets

Torque wrench

Diagonal cutters

Heavy gloves

Drain pan

Tape measure

White marker

Coolant (Honda Antifreeze/Coolant only, in a 50/50 mixture with water)

NOTE:

- Always use Honda Antifreeze/Coolant. Using a non-Honda coolant can result in corrosion, causing the cooling system to malfunction or fail.
- To avoid burning out the element, do not operate the engine block heater before it is installed in the vehicle and before you add coolant.

INSTALLATION

Customer Information: The information in this installation instruction is intended for use only by skilled technicians who have the proper tools, equipment, and training to correctly and safely add equipment to your vehicle. These procedures should not be attempted by "do-it-yourselfers."

1. Turn on the wiper switch, and move the wiper arms to the vertical position, then turn off the ignition.

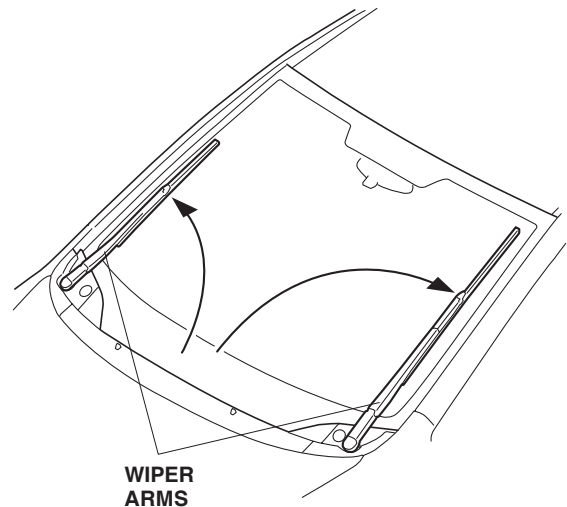

WIPER ARMS

- Disconnect the negative (-) cable from the battery, then open the positive cable cover and disconnect the positive (+) battery cable from the battery. Loosen the two battery holder nuts, and remove the battery holder. Then remove the battery upper cover, battery, and battery under cover.

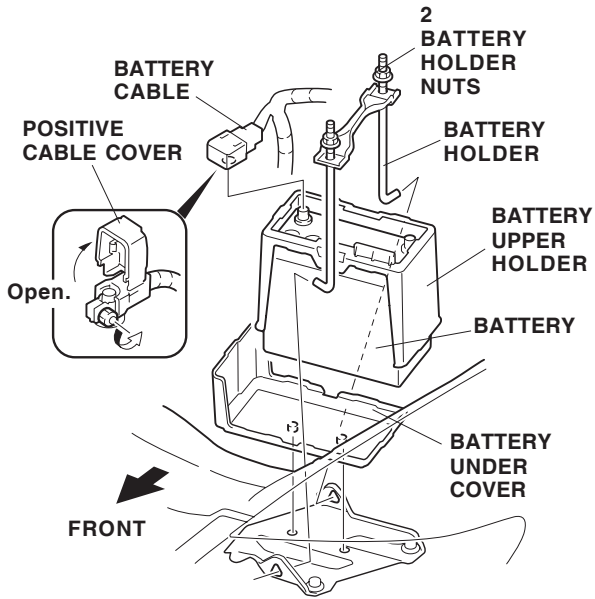

- Allow the engine and all cooling system components to cool down.
- Place a clean drain pan under the radiator drain plug, then remove the drain plug from the bottom of the radiator to drain the coolant. Remove the radiator cap to increase the flow.

NOTICE Radiator coolant will damage paint. Quickly rinse any spilled coolant from painted surfaces.

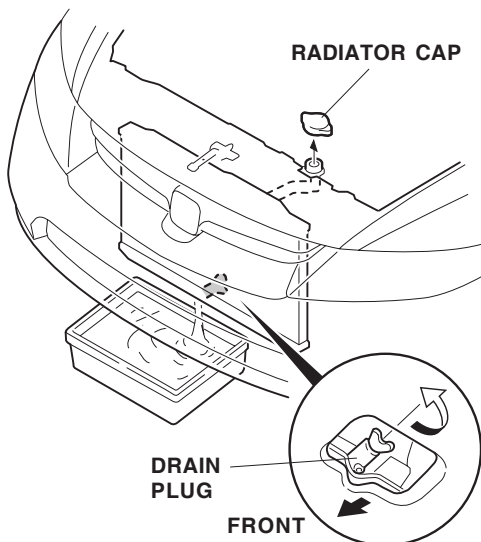

- Remove the cowl cover:
 - Remove the hood rear seal.
 - Disconnect the washer hose, and remove the three clips.
 - Remove the cowl cover (six clips and six hooks).

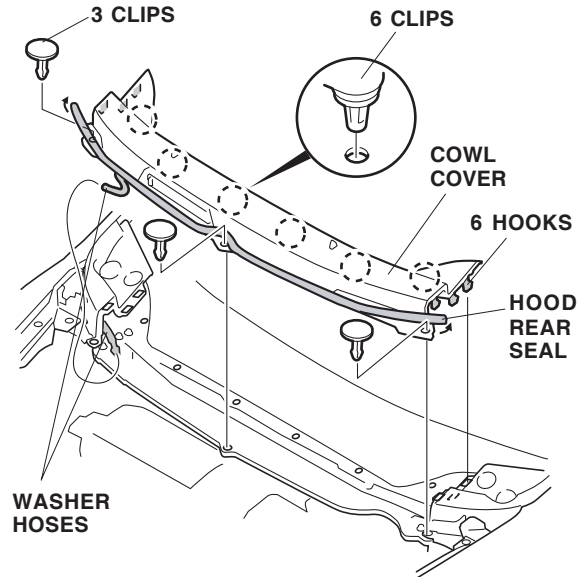

- Remove the cowl (nine bolts).

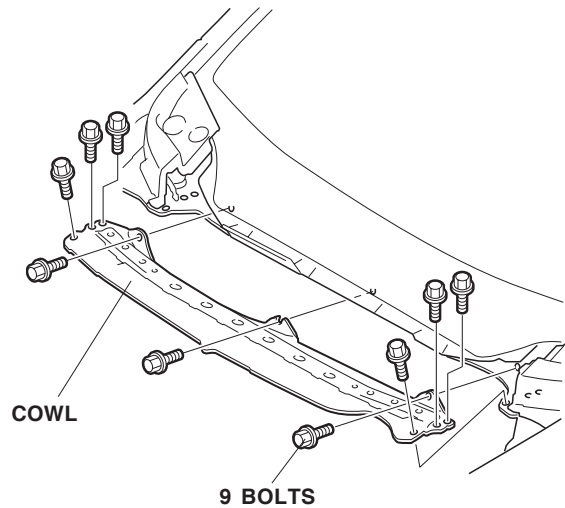

7. Remove the engine cover (four pins).

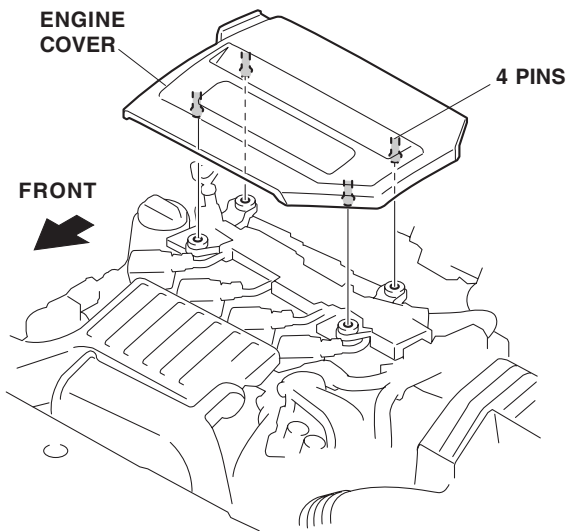

8. Using a tape measure and a white marker, mark the heater harness at locations A, B, and C using the measurement shown. Attach one wire tie with clip to the heater harness at point B. If the vehicle is equipped with fog lights, attach an additional wire tie with clip at point C.

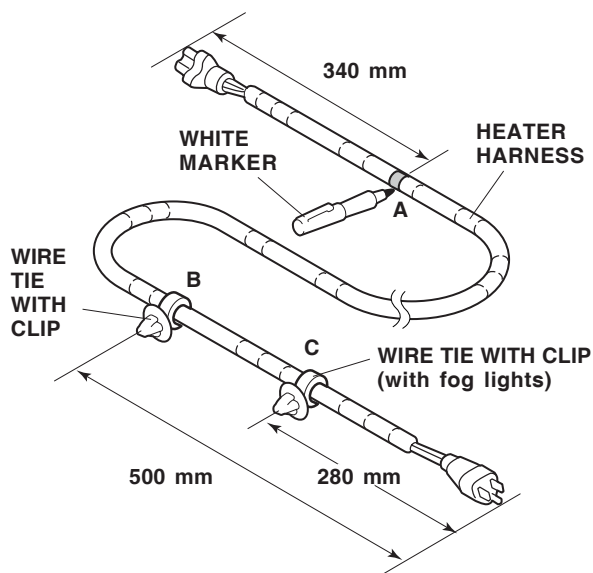

9. Locate and remove the engine block drain bolt and washer. Any coolant remaining in the engine jackets flows out of the bolt hole when the bolt is removed. (Retain the bolt and washer in case the block heater is removed.)

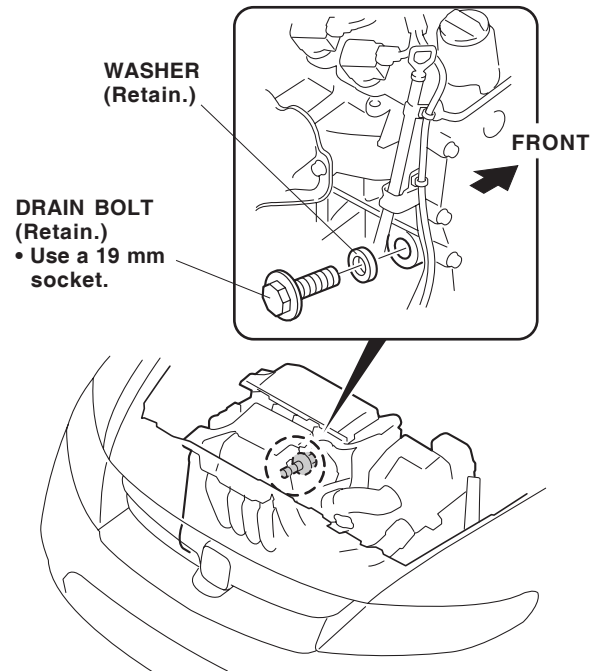

10. Install the new aluminum washer and the engine block heater into the bolt hole using a 24 mm socket and a torque wrench. Torque the engine block heater to 60 N·m (6 kg·m, 44 lb-ft).

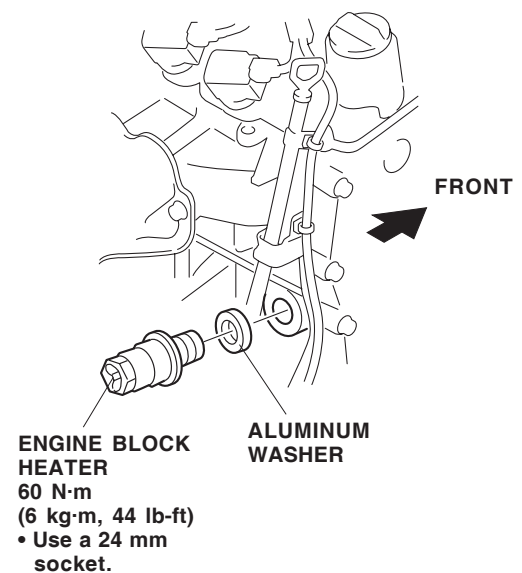

11. Route the heater harness down to the engine block heater, and plug the heater harness connector to the engine block heater.

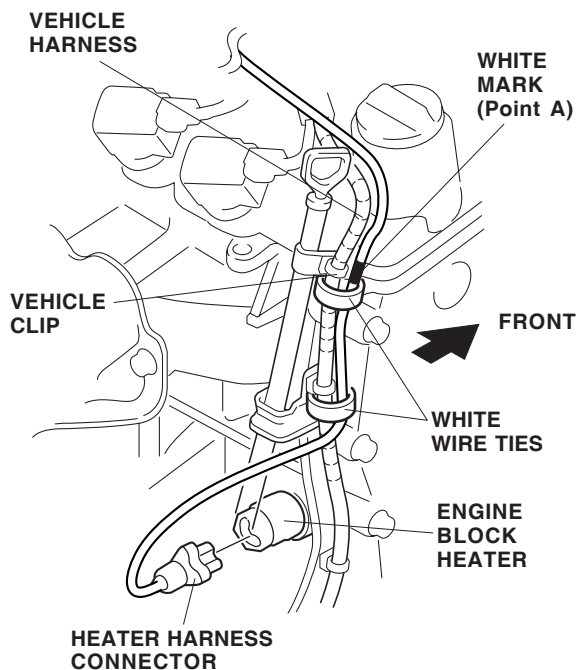

12. Secure the heater harness to the vehicle harness using two white wire ties. Attach one wire tie at the white mark (point A) made in step 8.

13. Route the heater harness as shown, and secure it to the vehicle harness using seven black wire ties. Do not secure the heater harness to the orange vehicle harness.

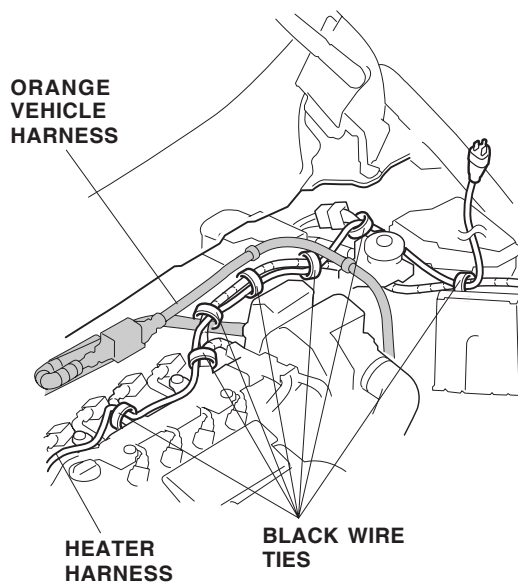

14. Continue routing the heater harness down below the fan shroud.

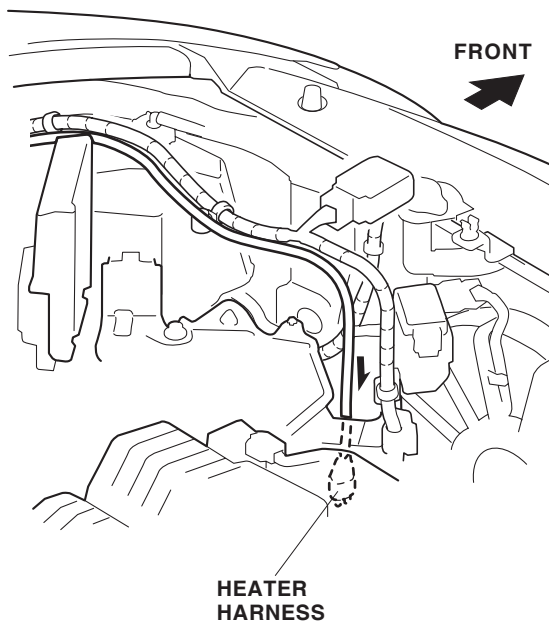

- Secure the wire tie with clip that you installed on the heater harness at point B to the vehicle frame. Route the heater harness to the front bumper opening.

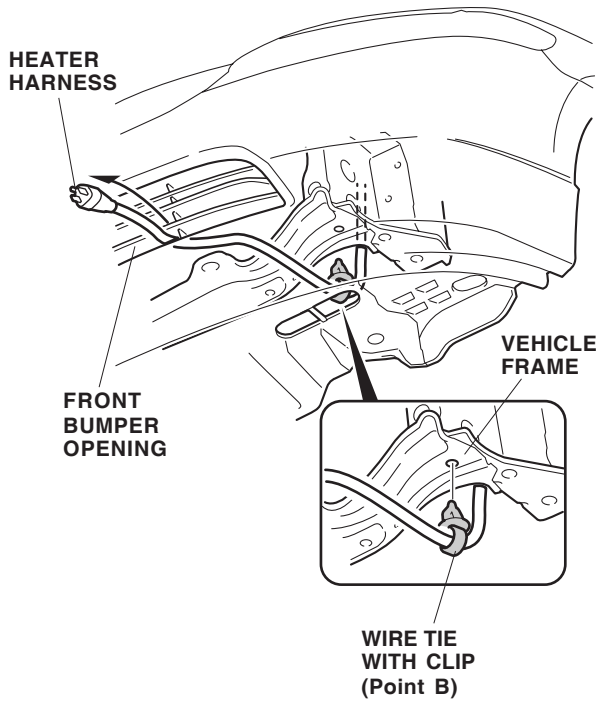

- Secure the heater harness to the vehicle harness using three black wire ties.

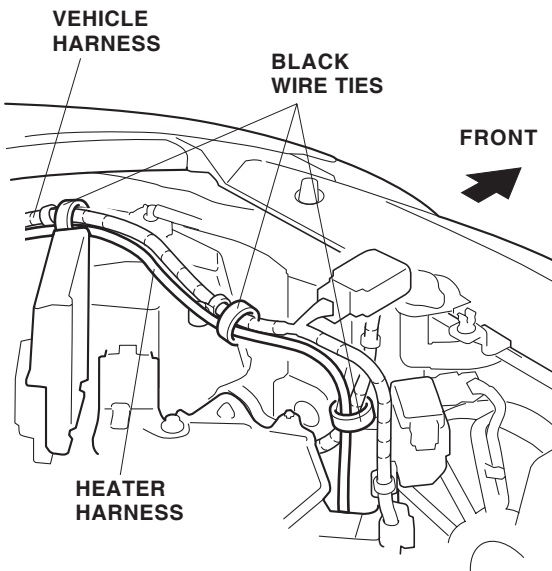

- Route the heater harness on the inside of the bumper opening, and secure it to the grille with a black wire tie as shown.

Without Fog Lights:

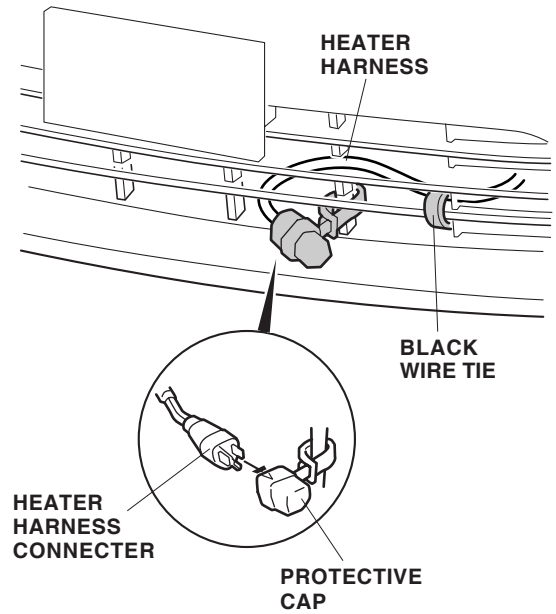

With Fog Lights:

- Remove the four clips from the bottom of the front bumper.

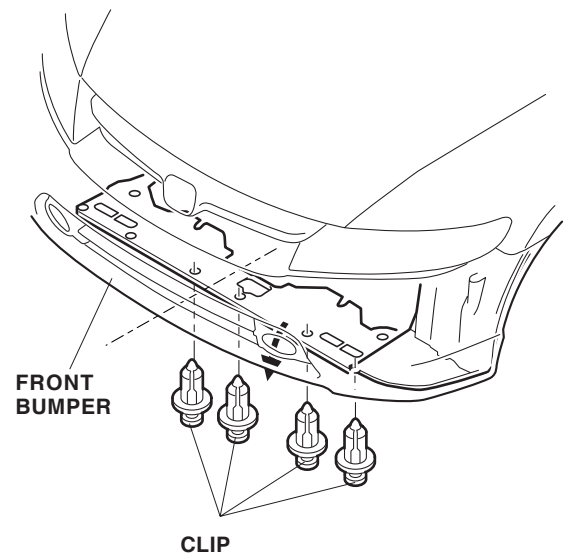

- Route the heater harness on the inner side of the bumper opening. Secure the heater harness to the fog light bracket with the wire tie with clip that you installed at point C.

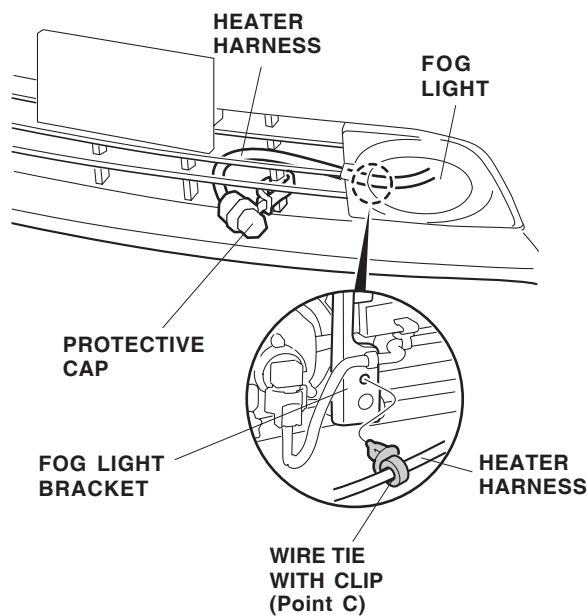

- Attach the protective cap to the grille, and plug the heater harness connector into the protective cap.

- Reinstall all removed parts. When reinstalling the engine cover, be careful not to pinch the heater harness.
 - Reinstall the radiator drain plug.
 - Fill the system with the recommended coolant. Follow the instructions described in the service manual to fill and bleed the cooling system.
 - Check the coolant reservoir for the correct level, and check the cooling system for signs of leakage. Repair as necessary.
 - Check that the heater harness is routed properly and all connectors are plugged in.
 - Put the drain bolt (removed in step 9) in the glove box.
 - Reconnect the negative cable to the battery.
 - Enter the customer's radio anti-theft code, and reset the radio station presets.
 - Reset the clock.
 - If the IMA battery level gauge (BAT) displays zero segments, start the engine, and hold it between 3,500 and 4,000 rpm (in Park or Neutral) until the IMA level gauge (BAT) displays at least three segments.
 - Because the battery was disconnected, you need to enter the Honda multi-matic feedback signal as described in the service manual.
- NOTE:** Whenever the battery is disconnected, the driver's AUTO window function is disabled.
- Start the engine. Push down on the driver's window switch until the window is fully open.
 - Pull up on the driver's window switch fully to close the window completely, then hold the switch for 2 seconds or more.
 - Lower and raise the driver's window to check operation of the driver's window AUTO function.
 - Test the AUTO window function.