

PARTS LIST

Back-up Sensor Attachment Kit P/N 08V67-SWA-100A

Back-up sensor control unit

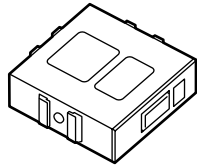

Buzzer



Back-up sensor harness

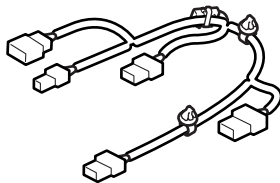

Back-up sensor subharness

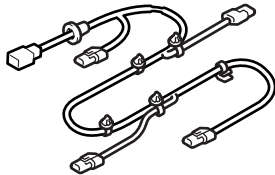

Right center sensor clip (Black)

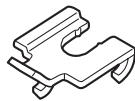

Left center sensor clip (White)

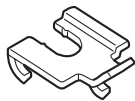

2 Corner sensor clips

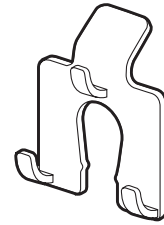

Control unit bracket



Connector clip

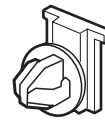

2 Wire ties

Wire tie with clip A

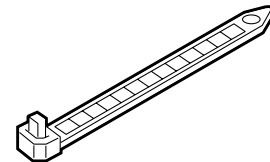

Wire tie with clip B

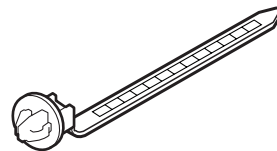
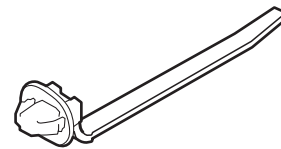

Wire tie with clip C

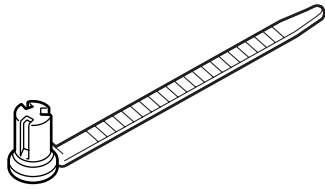

EPT sealer

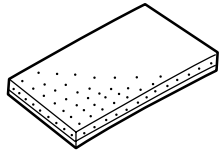

Fuse label

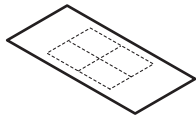

2 Self-tapping screws



Flange nut



Cable clip



Accessory user's information manual

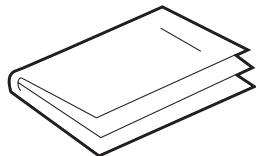

Back-up Sensor Kit

Right center sensor (blue)

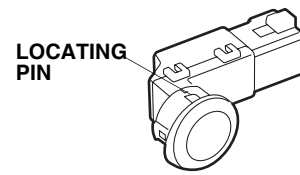

Left center sensor (blue)

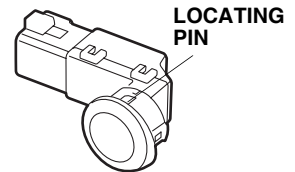

2 Corner sensors (white)

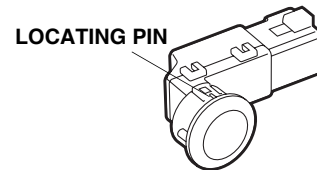

TOOLS AND SUPPLIES REQUIRED

Phillips screwdriver

Flat-tip screwdriver

Ratchet

8 mm and 10 mm Socket

Pushpin

Felt-tip pen

Drill

3 mm, 5 mm Drill bit

16 mm, 24 mm, and 26 mm Hole saw

Ruler

Eye protection (safety goggles, face shield, etc.)

10 mm Combination wrench

File

Diagonal cutters

Utility knife

Illustration of the Back-Up Sensors Installed on the Vehicle

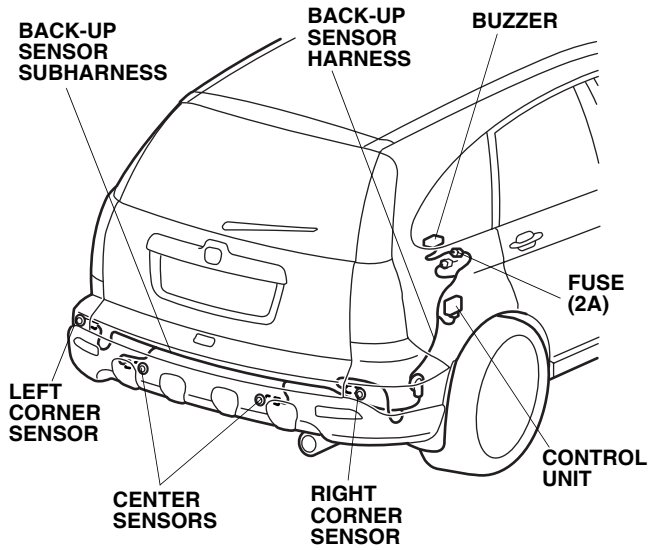

INSTALLATION

Customer Information: The information in this installation instruction is intended for use only by skilled technicians who have the proper tools, equipment, and training to correctly and safely add equipment to your vehicle. These procedures should not be attempted by “do-it-yourselfers.”

NOTE: If you are also installing a trailer hitch, install the back-up sensor first.

1. Make sure you have the anti-theft codes for the radio and navigation system if equipped, then write down the radio presets.
2. Disconnect the negative cable from the battery.

3. If equipped, remove the tonneau cover.

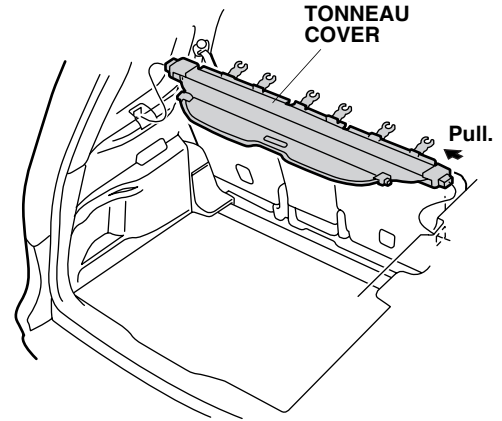

4. Remove the right rear door sill trim (three clips).

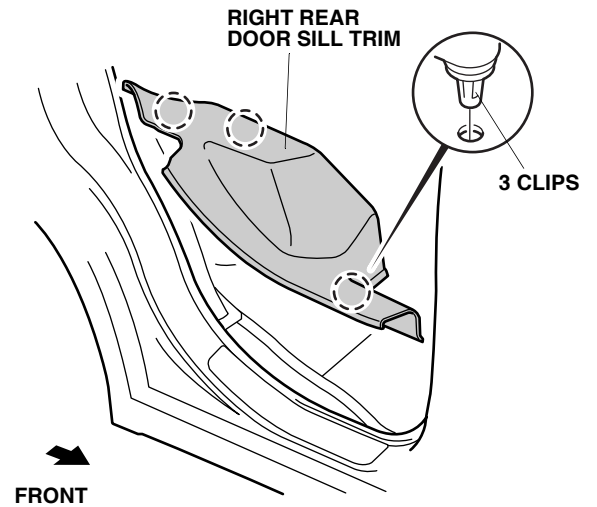

- Remove the trunk board (two hooks).

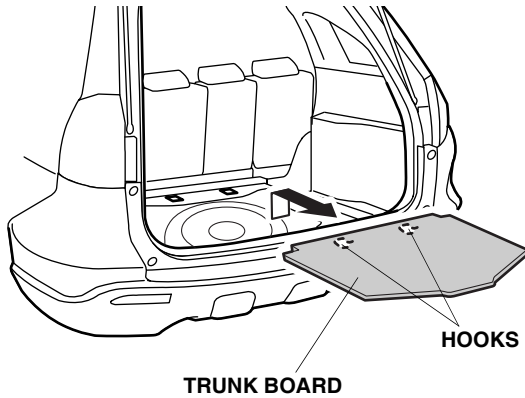

- Remove the weatherstrip from around the rear trim panel. Remove the rear trim panel (two bolts with tie-down hooks, two clips, and four clips).

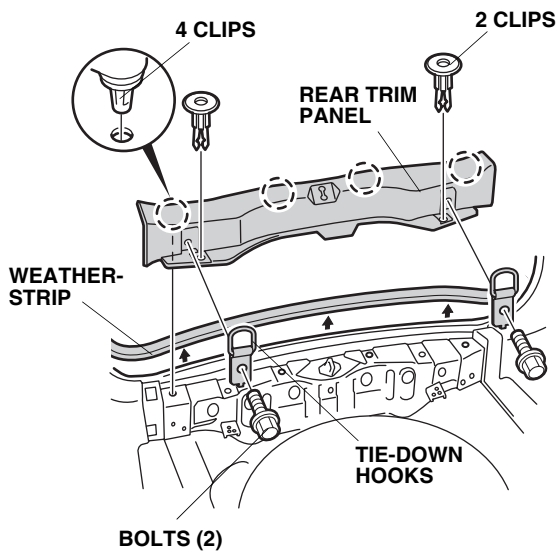

- Fold the rear seats forward, and remove the right rear lid from the right cargo area side trim (10 retaining tabs).
- Remove the vehicle bolt from the bracket of the right cargo area side trim panel.

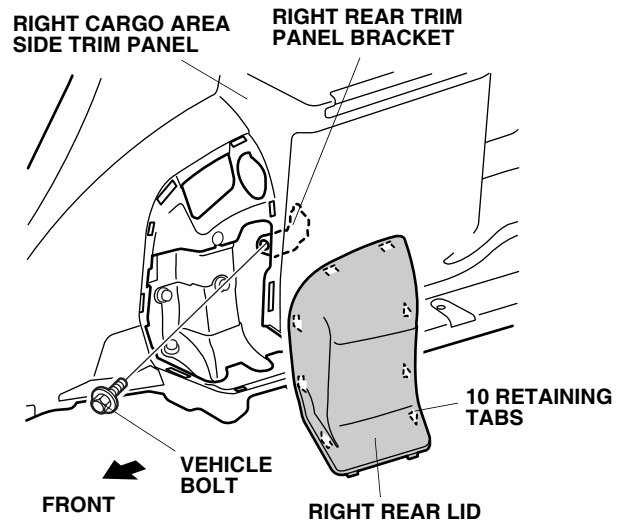

- Remove the rear door and tailgate weatherstrip from the right cargo area side and two clips from the trim panel.

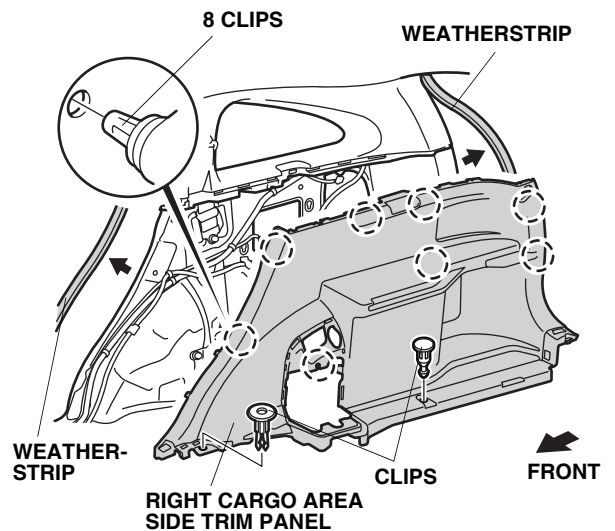

- Remove the right cargo area side trim panel (10 clips).

- Remove the seat belt from the right quarter pillar trim (one cover and one vehicle bolt).

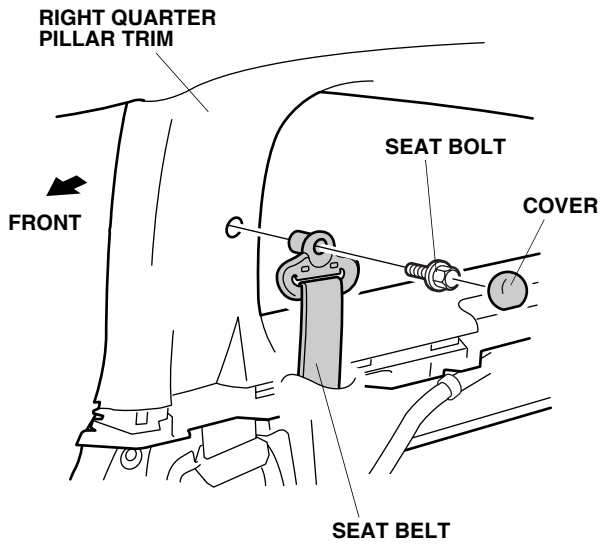

- Remove the right quarter pillar glass trim (seven clips).

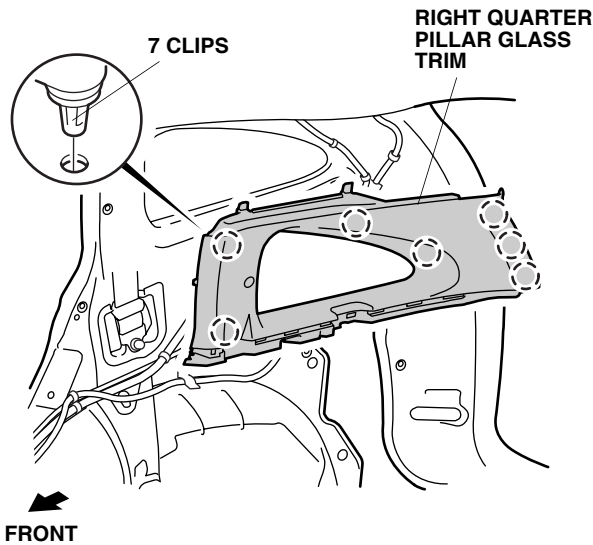

- Remove the left rear splash guards (four self-tapping screws).

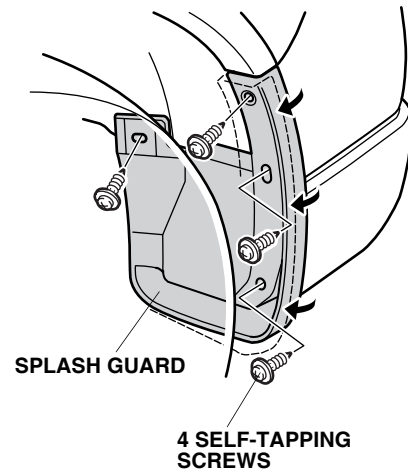

- Remove the right rear splash guard (four self-tapping screws).
- With the help of an assistant, remove the rear bumper (two bolt covers, two bolts, two flange bolts, and three clips).

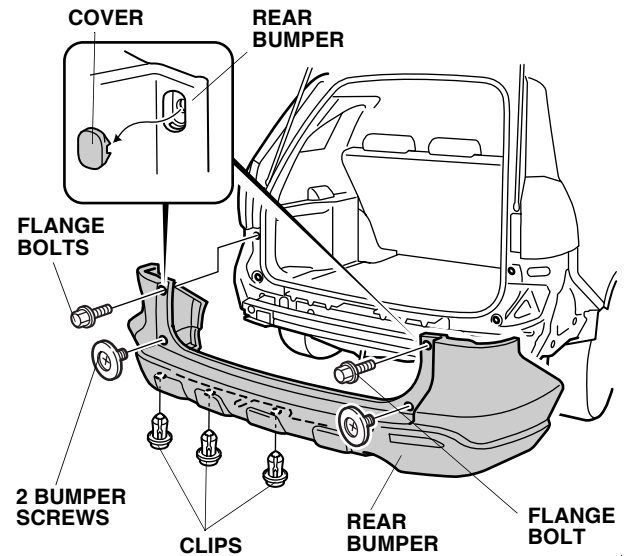

16. Get the back-up sensor harness, and attach the 2A fuse label (2A) to the fuse case.

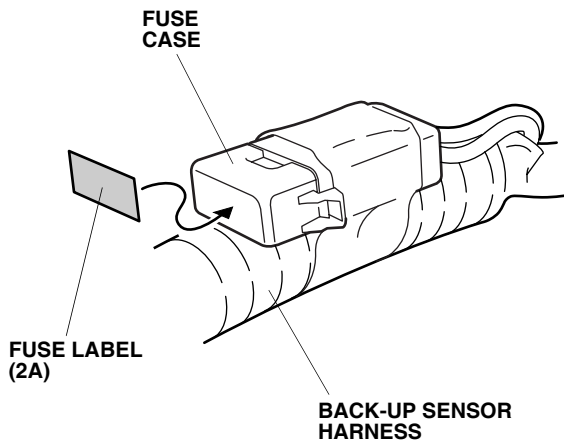

17. Install the cargo area, remove the clip that secures the vehicle 6-pin connector to the vehicle panel, and disconnect the vehicle 6-pin connector.

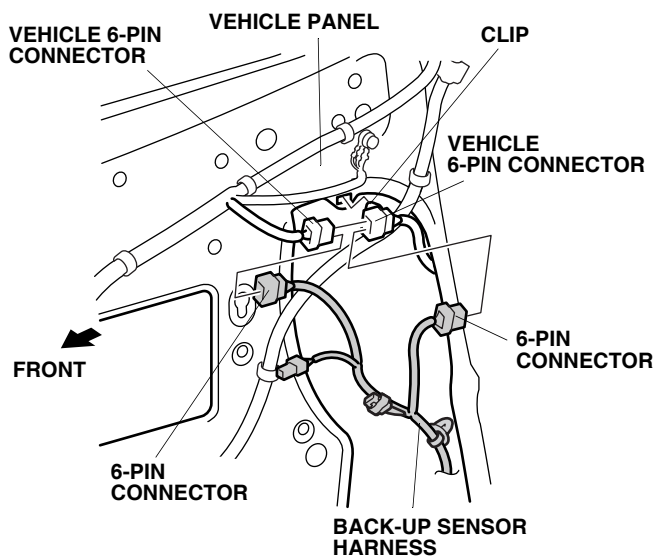

18. Plug the back-up sensor 6-pin connector into the vehicle 6-pin connector. Plug the other vehicle 6-pin connector into the other back-up sensor harness 6-pin connector.

19. Reinstall the vehicle 6-pin connector clip to the vehicle panel.

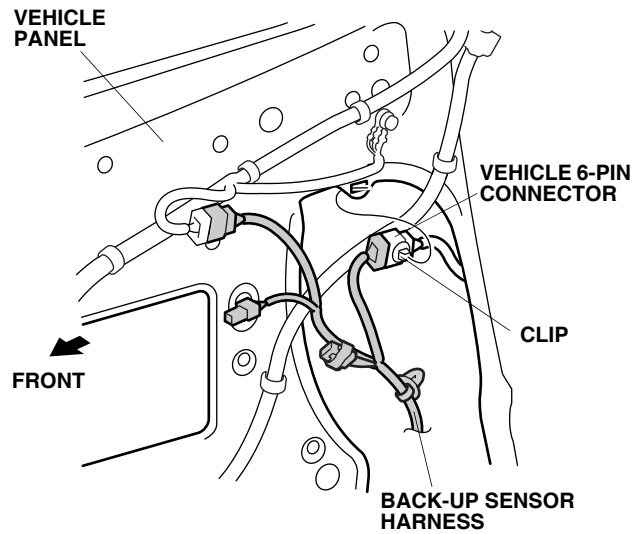

20. Secure the other 6-pin connector to the vehicle harness with one wire tie.

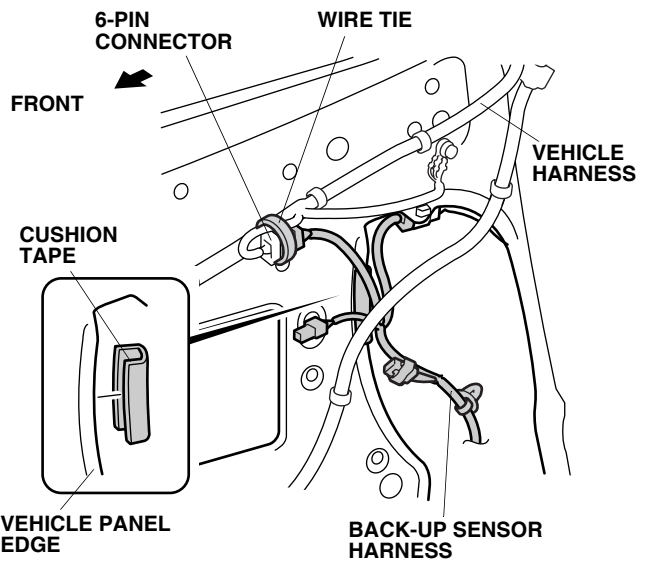

21. Using isopropyl alcohol on a shop towel, thoroughly clean the area where the cushion tape will attach. Attach the cushion tape to the edge of the vehicle panel at the location shown.

22. Slide the control unit bracket onto the control unit. Make sure that the three switches are in the down position.

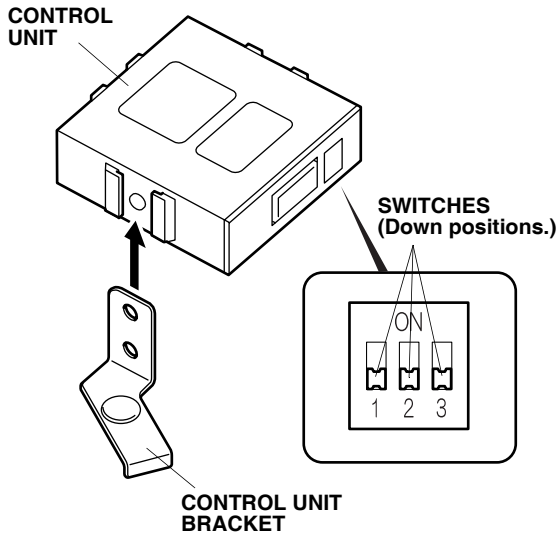

23. Plug the back-up sensor harness 14-pin connector into the control unit.

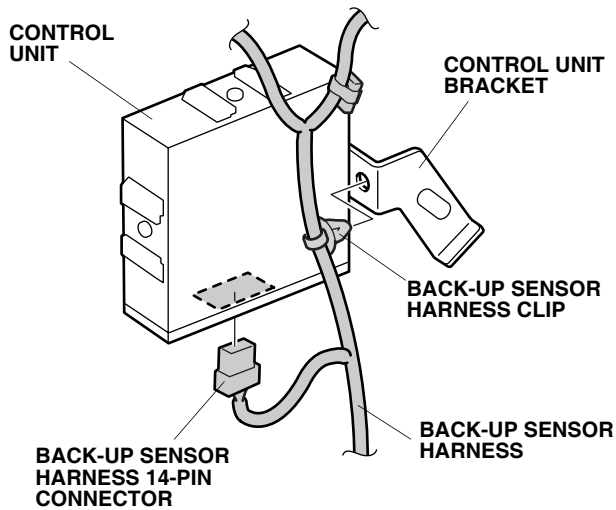

24. Attach the back-up sensor harness clip to the control unit bracket.

25. Insert the stud from the control unit bracket into the hole in the vehicle panel, make sure that the bracket tab is seated in the large hole. Secure the bracket to the vehicle panel using the 6 mm flange nut.

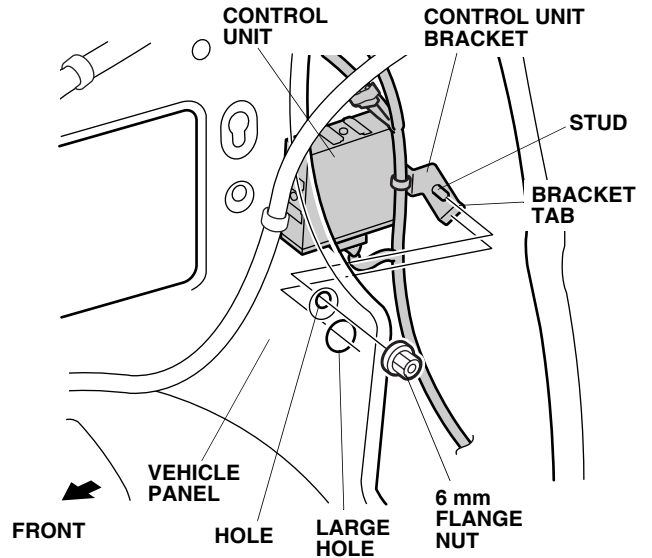

26. Install the back-up sensor harness clip into the hole in the vehicle panel.

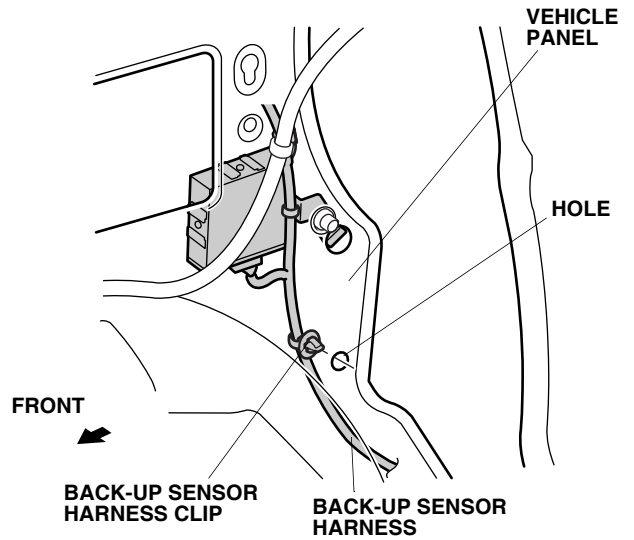

27. Using a utility knife, trim off the right quarter pillar glass trim in the area shown.

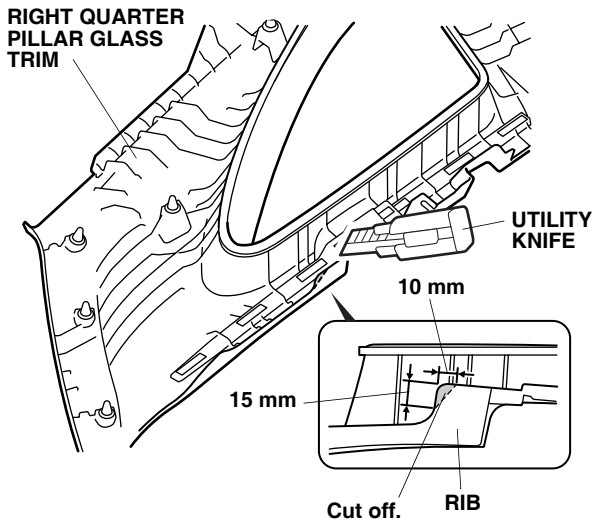

28. Using a ruler and a felt-tip pen, measure and mark the right quarter pillar glass trim in the area shown.

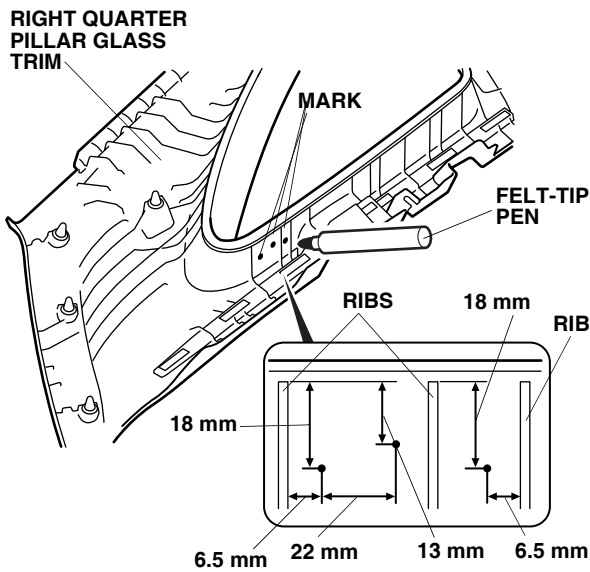

29. While wearing eye protection, drill a 4 mm hole at the two marked points, and remove any burrs.

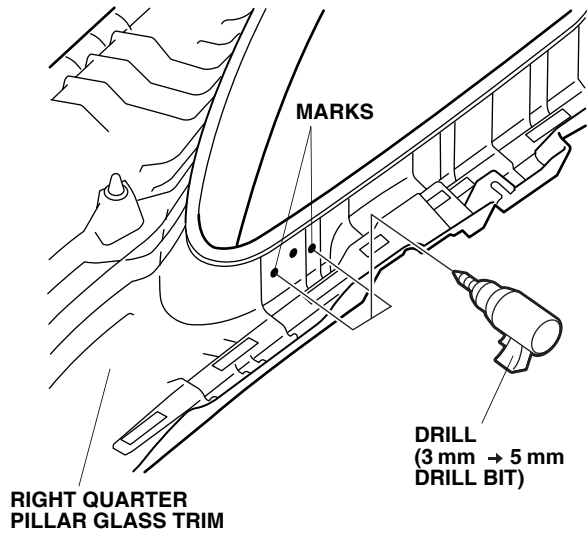

30. While wearing eye protection, drill a 3 mm bit, drill a hole at the marked point, then finish with a 16 mm hole saw. Remove any burrs.

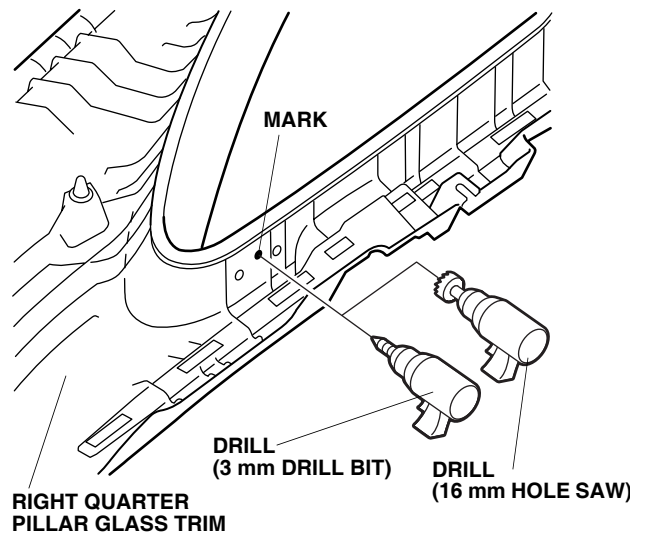

- Using isopropyl alcohol on a shop towel, clean the right quarter pillar glass trim where the double-sided tape will attach. Remove the adhesive backing from the buzzer. Route the buzzer 2-pin connector through the 16 mm hole, and install the buzzer in the right quarter pillar glass trim with the two self-tapping screws. Install with the on/off switch and the volume control toward the front.

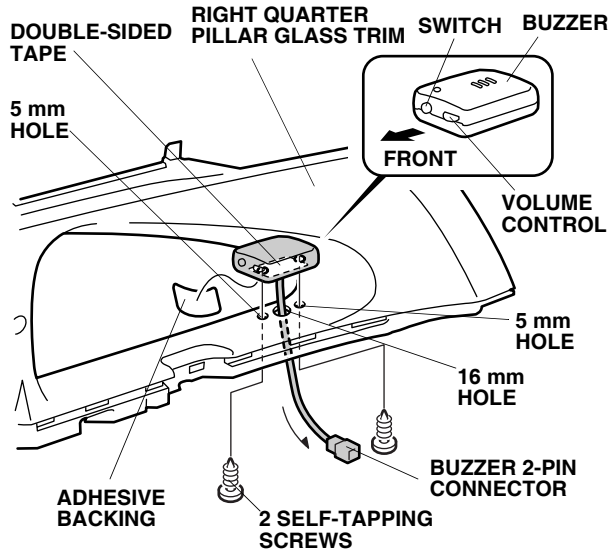

- Reinstall the right quarter pillar glass trim.
- Plug the back-up sensor harness 2-pin connector into the buzzer 2-pin connector.

With Vehicle Harness

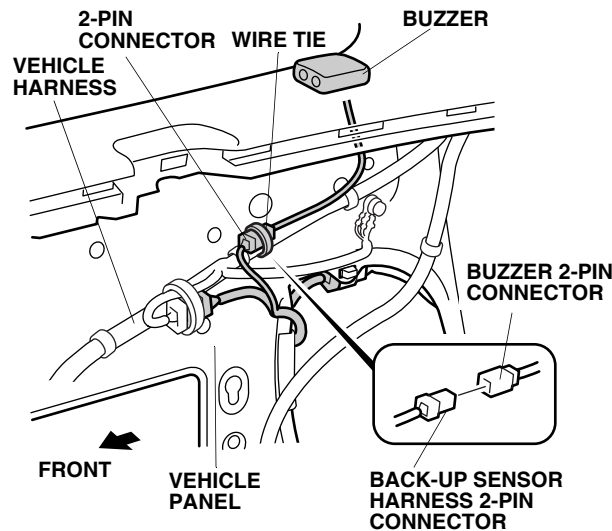

- Secure the 2-pin connector to the vehicle harness with one wire tie (without vehicle harness: wire tie with clip B).

Without Vehicle Harness

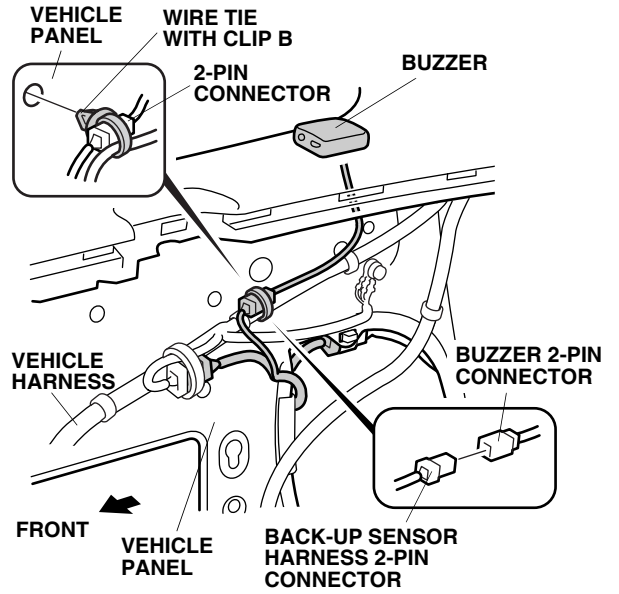

- Secure the buzzer harness to the vehicle harness with one wire tie.

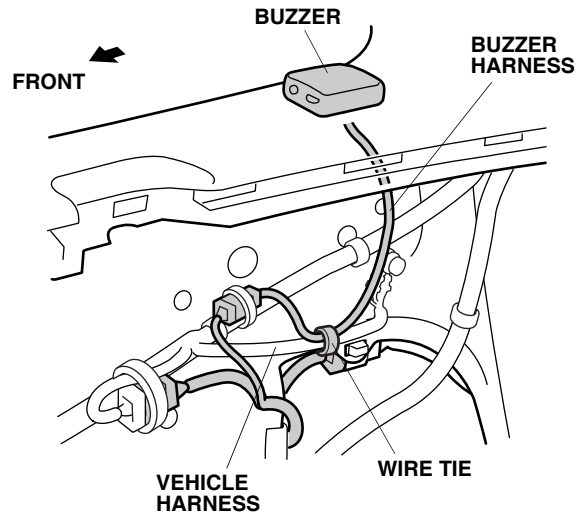

36. At the rear corner of the vehicle, remove the vehicle grommet.

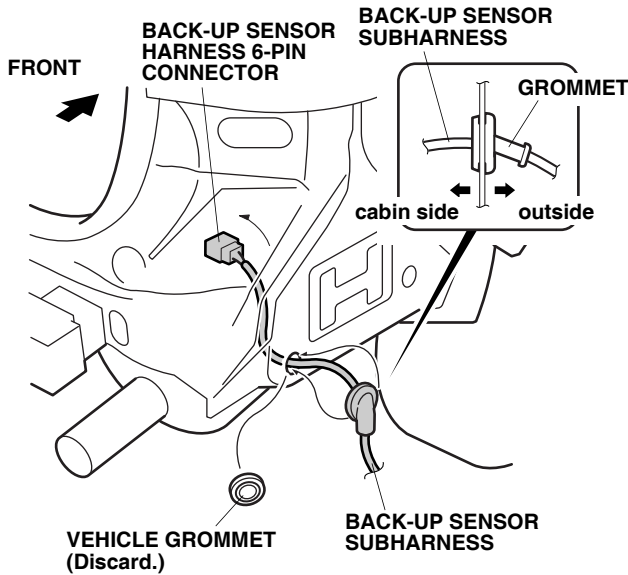

37. Route the back-up sensor subharness 6-pin connector through the hole where the vehicle grommet was removed, and seat the grommet of the back-up sensor subharness grommet in the vehicle hole.
38. Install the connector clip to the back-up sensor subharness 6-pin connector.

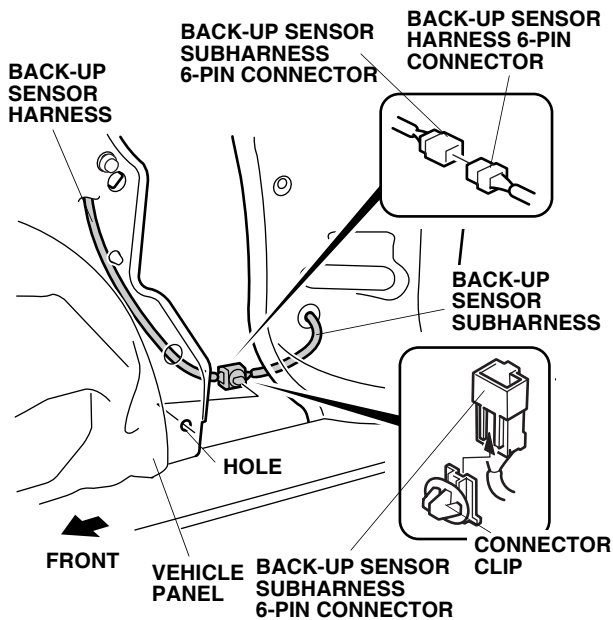

39. Plug the back-up sensor subharness 6-pin connector into the back-up sensor harness 6-pin connector, and install the connector clip. Secure the clip in the vehicle panel hole in the area shown.

40. Route the back-up sensor subharness as shown, and install the back-up sensor subharness clip into the vehicle panel hole. Secure the back-up sensor subharness:

With Rear Bumper Beam: Using isopropyl alcohol on a shop towel, clean the rear bumper beam where the cable clip will attach. Insert the back-up sensor subharness into the holder of the cable clip. Remove the adhesive backings from the cable clip, and attach the cable clip to the rear bumper beam as shown.

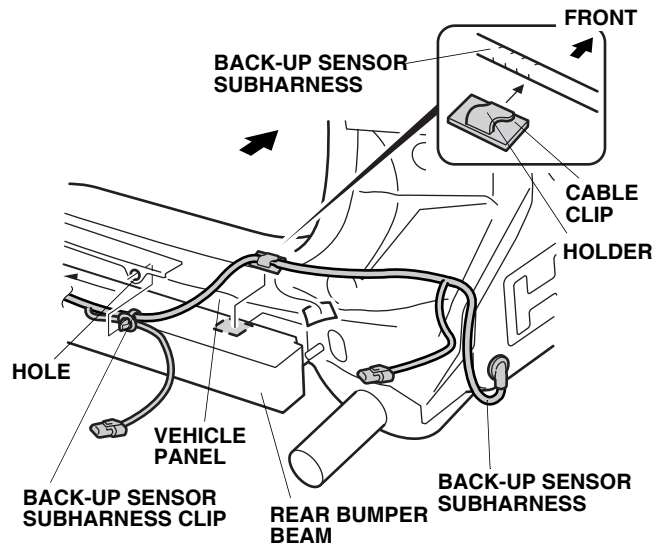

41. Route the back-up sensor subharness as shown. Attach the back-up sensor subharness clips into the holes in the vehicle panel.

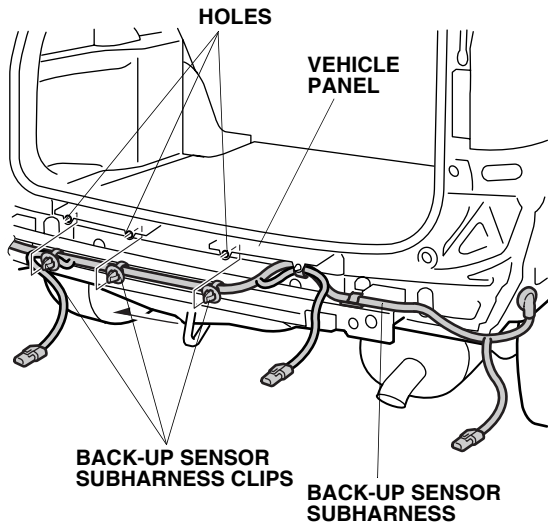

42. Using a pushpin, pierce the center and bottom of each preset on the passenger's side of the rear bumper. Pierce the center and top of the other three preset marks on the bumper. There are several marks on the inside of the rear bumper; make certain that you locate and pierce the proper preset marks.

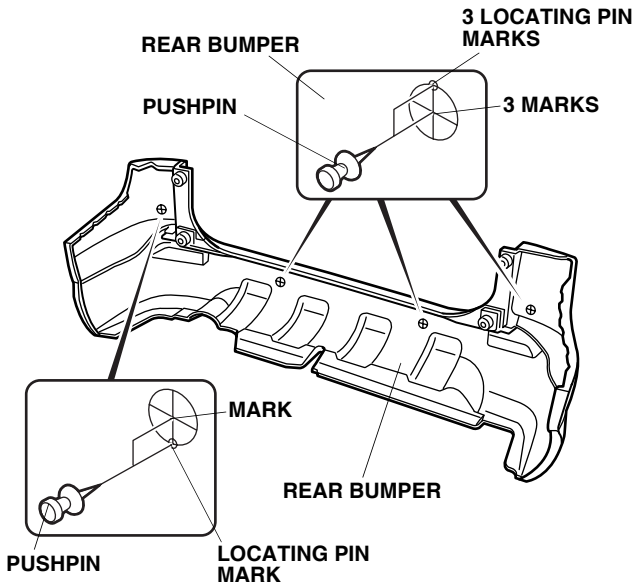

43. While wearing eye protection, drill a 3 mm hole at the eight pierced points you just made from the painted side of the rear bumper.

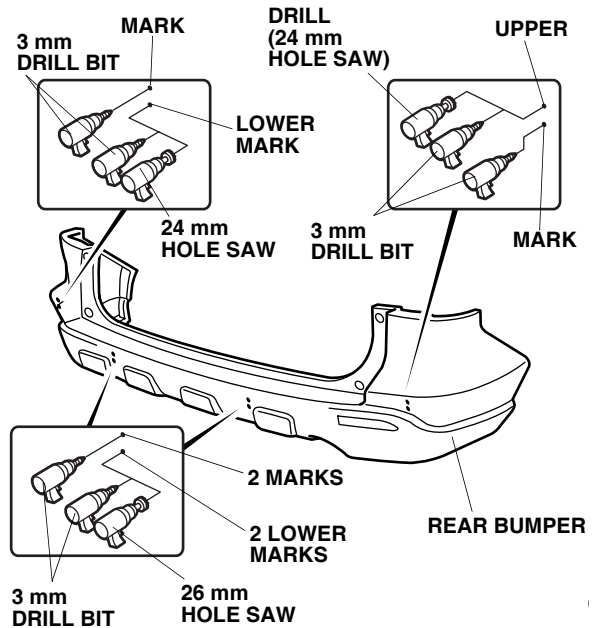

NOTE: Center holes are larger than the outer holes!

44. Enlarge the corner holes to 24 mm, and enlarge the center holes to 26 mm using a hole saw. Remove any burrs.
45. Install the two corner sensors to the rear bumper using the two corner sensor clips.

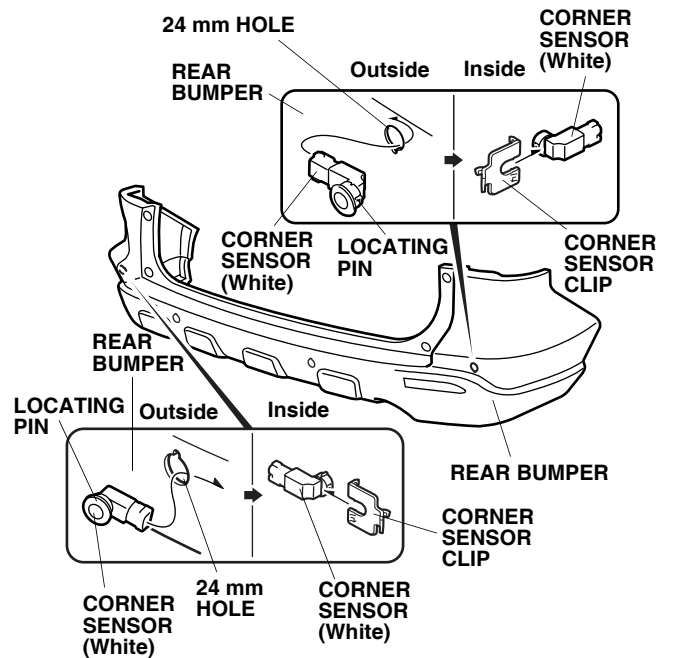

46. Install the right center sensor and left center sensor on the rear bumper using right and left center sensor clips.

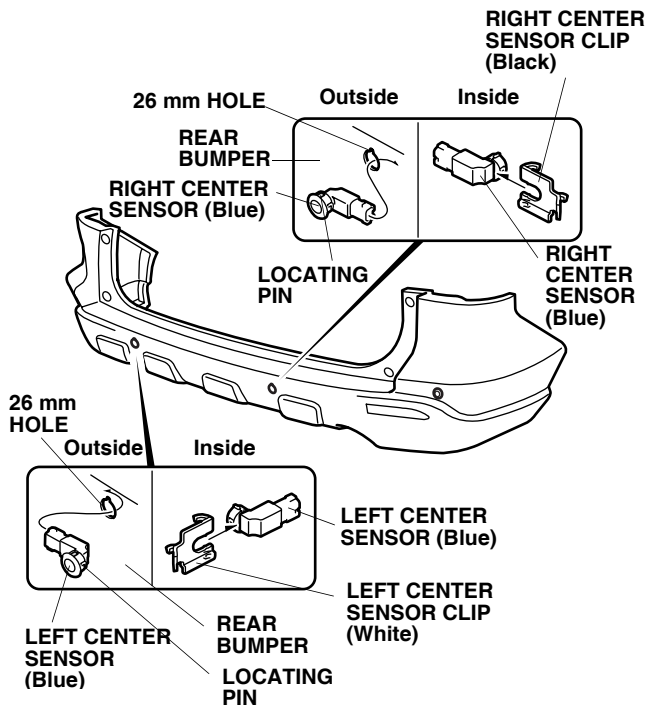

47. Remove the rear bumper absorber from the rear bumper beam.

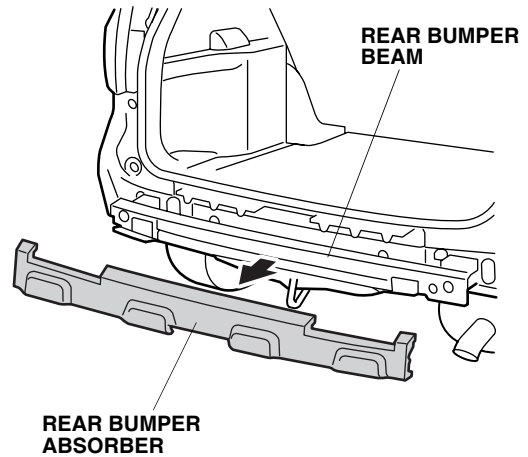

48. Using a utility knife, cut the rear bumper absorber along the preset line at the location shown.

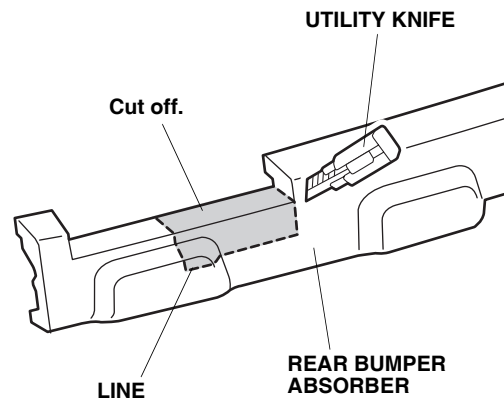

49. With the help of an assistant, bring the rear bumper near the vehicle, plug in the four back-up sensor subharness 2-pin connectors into the sensors, and reinstall the rear bumper.

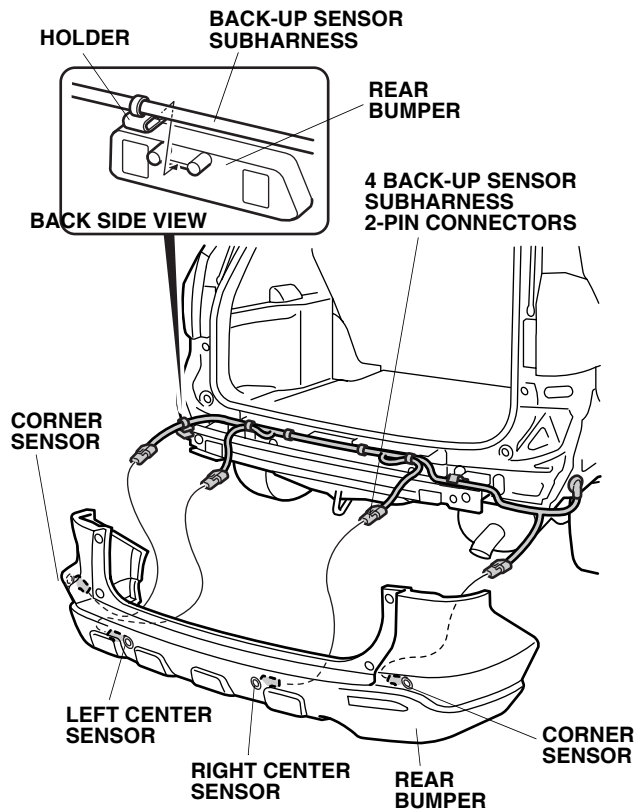

50. Attach the holder of the back-up sensor subharness to the rear bumper as shown.

51. Check that all wire harnesses and cables are routed properly and that all connectors are plugged in.
52. Reinstall all removed parts.
53. Reconnect the negative cable to the battery.
54. Enter the anti-theft codes for the radio and navigation systems, then enter the customer's radio presets.
55. Reset the clock.
56. Test that the back-up sensors work as described in the Accessory User's Information Manual, which is supplied in the kit.