



INSTALLATION INSTRUCTIONS

Accessory
SIDE UNDER SPOILER

Application
2008 ACCORD
2-DOOR

Publications No.
All 37572

Issue Date
SEP 2007

PARTS LIST

Left side under spoiler

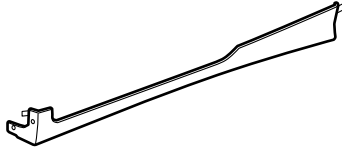

Right side under spoiler

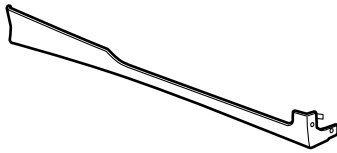

2 Side lower brackets

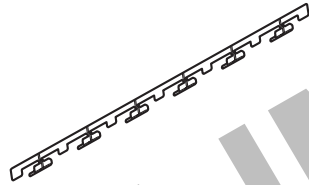

Template

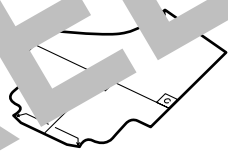

4 Self-tapping screws, 5 x 18 mm



2 Clamps

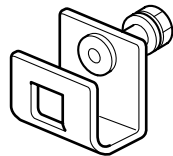

2 Side bottom brackets

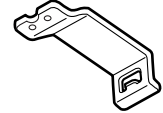

4 Screws



TOOLS AND SUPPLIES REQUIRED

Phillips screwdriver

Pushpin

Touch-up paint

Ratchet

Socket

Gloves

Masking tape

Shop towel

Isopropyl alcohol

Utility knife

Dryer

Felt-tip pen

INSTALLATION

Customer Information: The information in this installation instruction is intended for use only by skilled technicians who have the proper tools, equipment, and training to correctly and safely add equipment to your vehicle. These procedures should not be attempted by “do-it-yourselfers.”

NOTE:

- Thoroughly clean the bottom of the body from the rear of the front wheels to the front of the rear wheels.
- Using isopropyl alcohol on a shop towel, thoroughly clean the areas where the side lower bracket and the side under spoilers will attach. Allow to dry thoroughly before installing the side lower bracket and the side under spoilers.
- If oil, moisture, dust, etc. is not thoroughly removed, the side lower bracket may detach and the side lower skirt may come off the vehicle. Be sure to clean them before installing.
- Be careful not to damage the body finish when installing the side under spoilers.
- Before installing the side under spoilers, raise the vehicle off the ground and support it by placing racks in the proper locations as described in the Service Manual.
- After installing, hold the side lower bracket and the side under spoilers firmly against the vehicle body with the palm of your hand.
- These installation instructions show the left side under spoiler being installed. The same procedure applies to installing the right side under spoiler.
- Wear gloves to protect your hands during handling the side lower bracket.
- This side under spoiler kit should be installed only if the ambient air temperature is 60°F (15°C) or above.
- To allow the adhesive to cure, do not wash the vehicle for 24 hours.
- The side under spoiler cannot be installed with the splash guards.

Installing the Side Under Spoiler

1. Position the left side under spoiler on the vehicle body to check the installation position. Using isopropyl alcohol on a shop towel, clean the surface of the vehicle thoroughly where the left side under spoiler will attach to ensure secure adhesion of the double-sided adhesive tape.

Using isopropyl alcohol on a shop towel, thoroughly clean the surface where the left side under spoiler will attach.

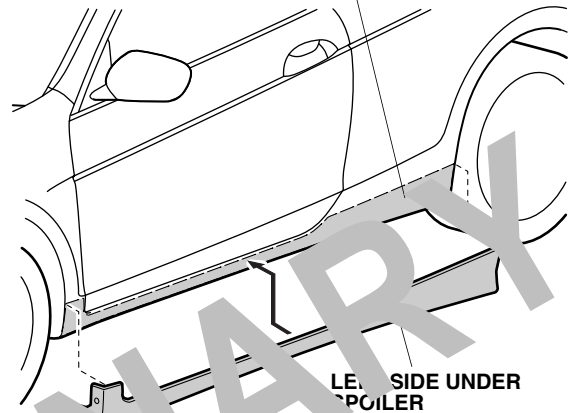

742001AY

2. Position the template A on the vehicle body. Using a felt-tip pen, mark the vehicle body at the distance shown.

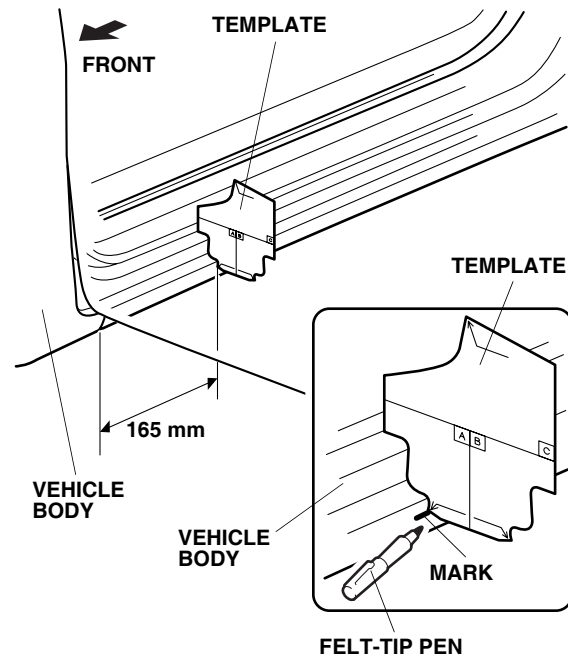

761901BE

- Position template (B) on the vehicle body. Using a felt-tip pen, mark the vehicle body at the distance shown.

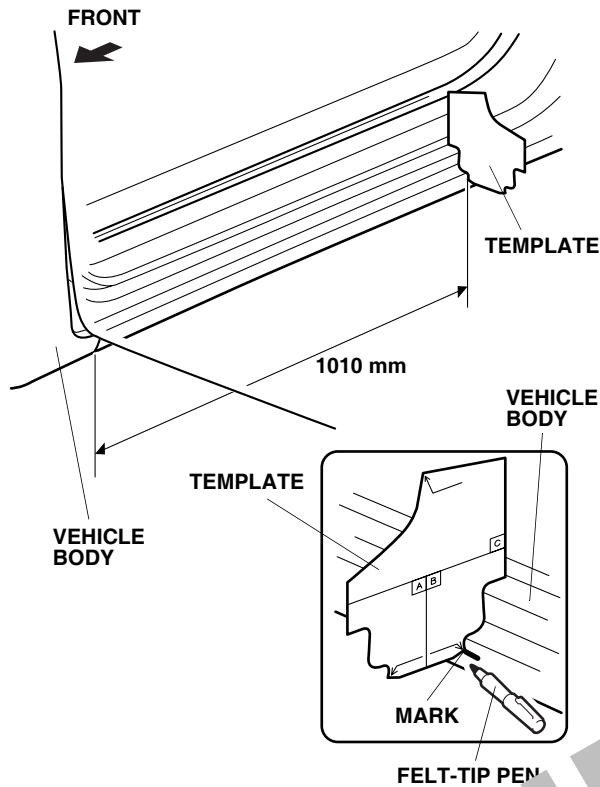

- Position the template (C) on the vehicle body. Using a felt-tip pen, mark the vehicle body at the distance shown.

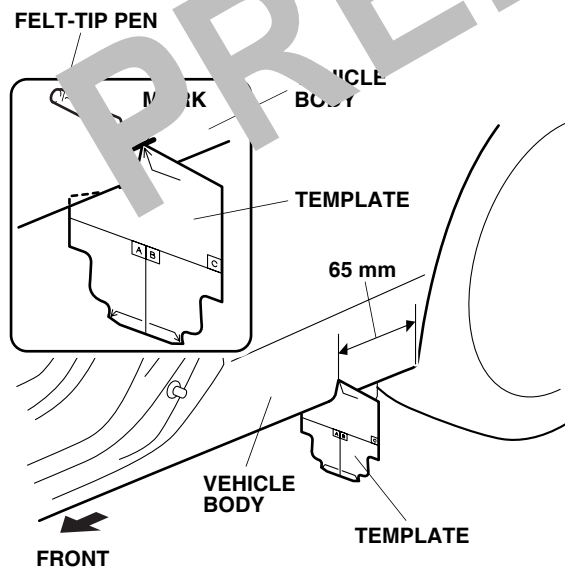

- Using a utility knife, cut both ends and the centers of the adhesive backing on the side lower bracket, and remove the cut backing pieces from both ends.
- Attach a piece of masking tape to each of the cut ends, and temporarily attach them to the front of the side lower bracket as shown.

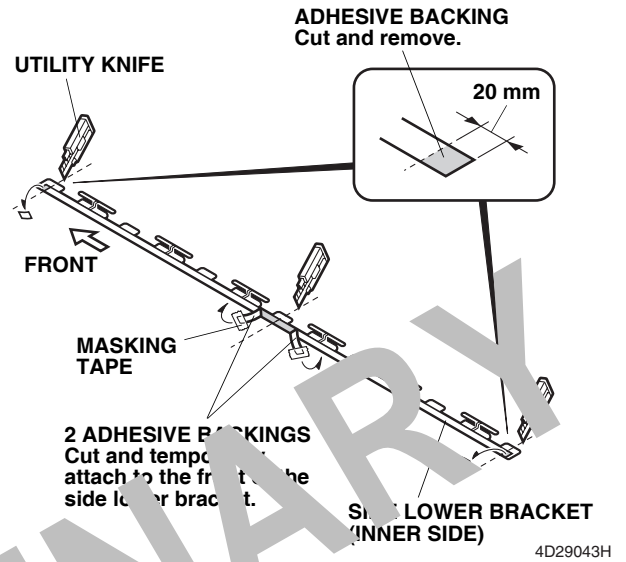

7. Position the side lower bracket as shown. Temporarily adhere the side lower bracket to the vehicle body by pressing the front end of the side lower bracket (where you removed the adhesive backing) against the vehicle body.
 - Position the side lower bracket on the vehicle body with care not to bend it and adhere it securely to the vehicle body.
 - If the side lower bracket comes off after temporarily adhering it, repeat step 1 and clean the surface where the side lower bracket will attach using isopropyl alcohol.

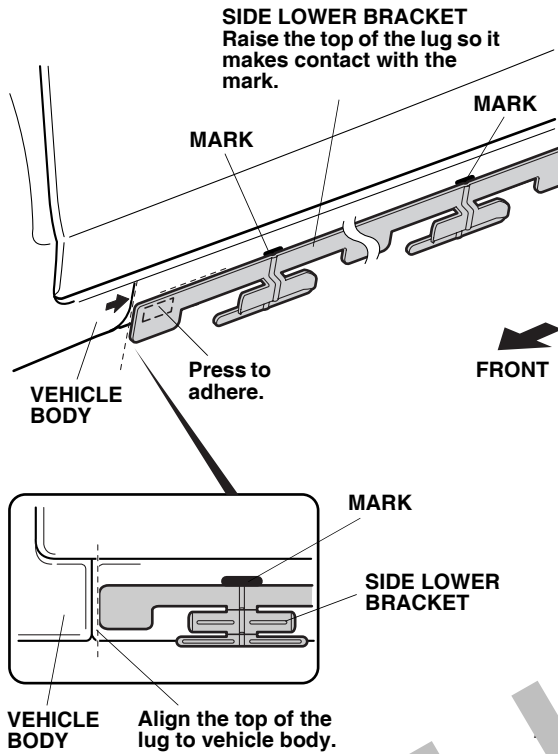

8. Raise the side lower bracket so that it makes contact with the marks.
9. Press the rear end of the side lower bracket (where you removed the adhesive backing) to adhere the side lower bracket firmly to the vehicle body.

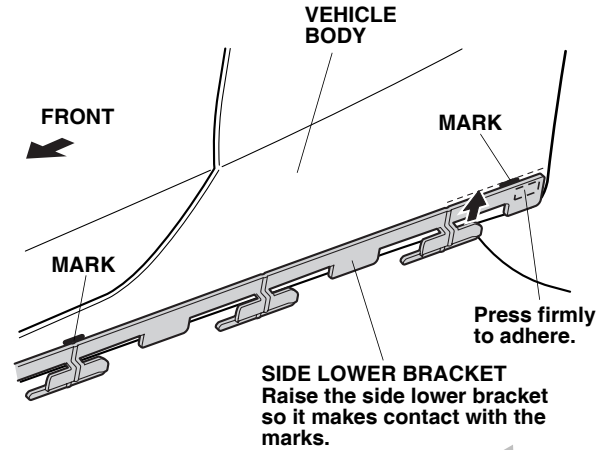

742013DY

10. Press the front end of the side lower bracket (where you removed the adhesive backing) to adhere the part firmly to the vehicle body.

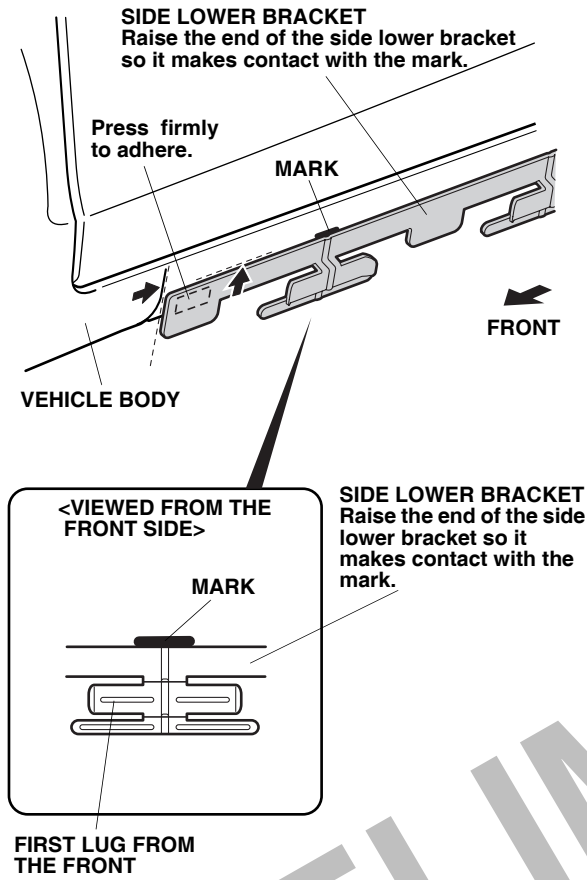

14CY

11. Raise the top of the center of the side lower bracket so that it lightly makes contact with the mark.
12. Press the side lower bracket in the center (where the adhesive tape was removed) to adhere it firmly.
 - Wear gloves to protect your hands during this operation.

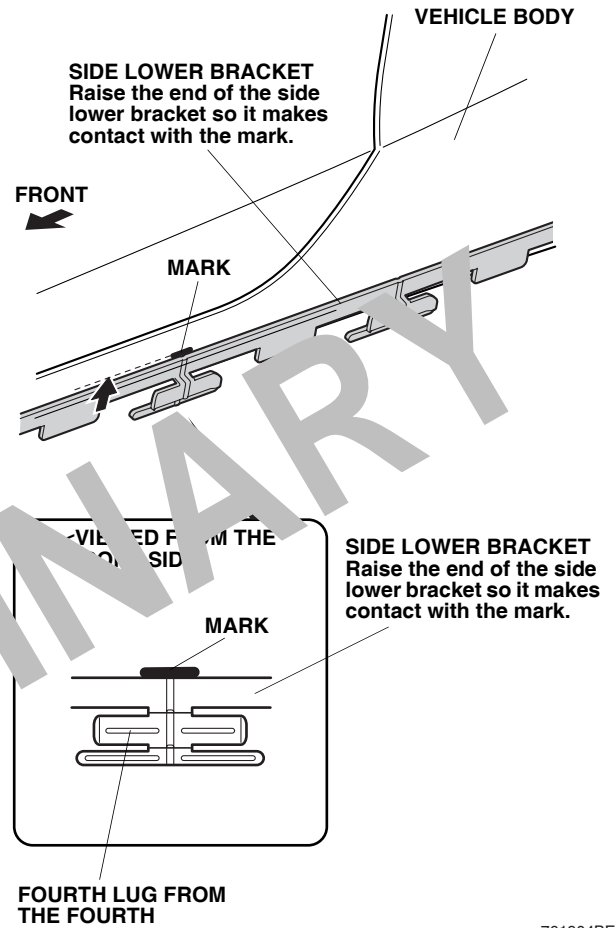

761904BE

13. Make sure the side lower bracket makes contact with the mark. Apply pressure to the side lower bracket starting from the center and moving to the ends while removing the adhesive backing that was temporarily attached to the lower bracket.

2 ADHESIVE BACKINGS

Press the side lower bracket lightly from the center to the ends while removing the adhesive backing.

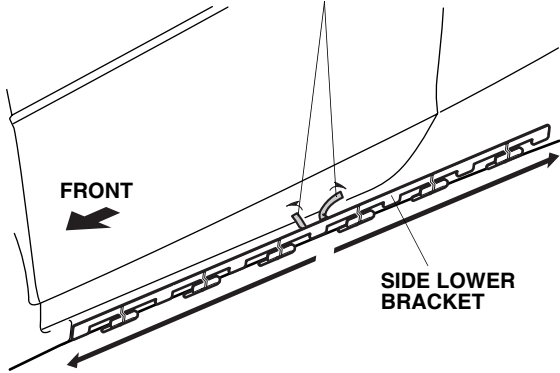

742016BY

- When the shop room temperature is below 60°F (15°C), warm up the entire of the side lower bracket close to the body temperature.

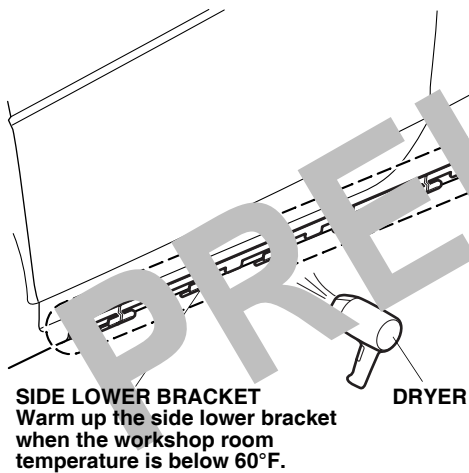

SIDE LOWER BRACKET
Warm up the side lower bracket when the workshop room temperature is below 60°F.

742018AY

14. Adhere the side lower bracket to the vehicle body by pressing it firmly where the double-sided adhesive tape is attached with the palms of your hands or fingers.

- Do not push the side under spoiler installation plates. This can deform the installation plates and disable you from installing the side under spoiler.

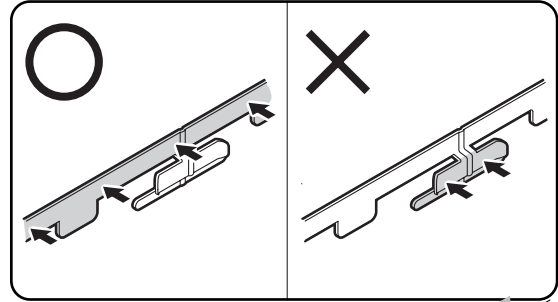

SIDE LOWER BRACKET
Press the entire surface of the double-sided adhesive tape.

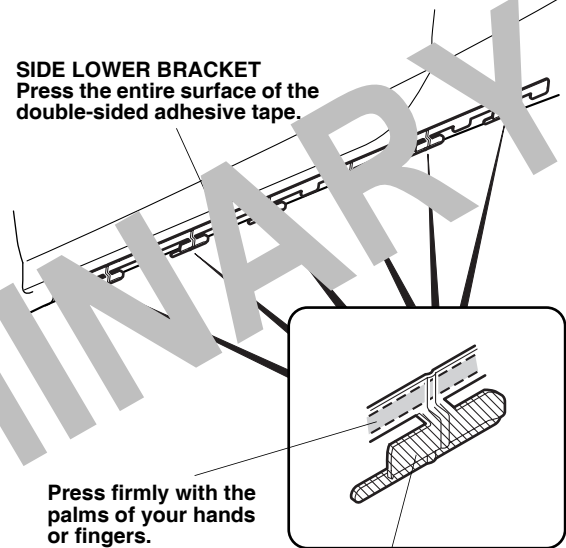

Press firmly with the palms of your hands or fingers.

Do not push here.

742019AY

15. Using a pushpin, make small holes through the center of the two clips.

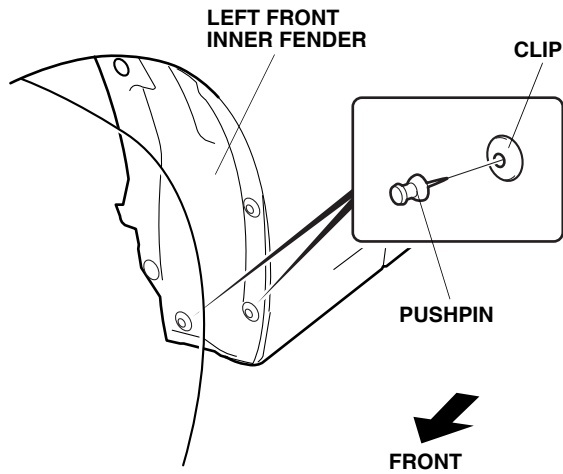

742021AY

16. Position the left side under spoiler and fit the side bottom bracket to the left side under spoiler, and mark the under coat.
17. Cut into the marked area of the under coat with a utility knife, and remove the under coat from the surface and inner side of the vehicle panel. Apply touch-up paint to the vehicle panel.

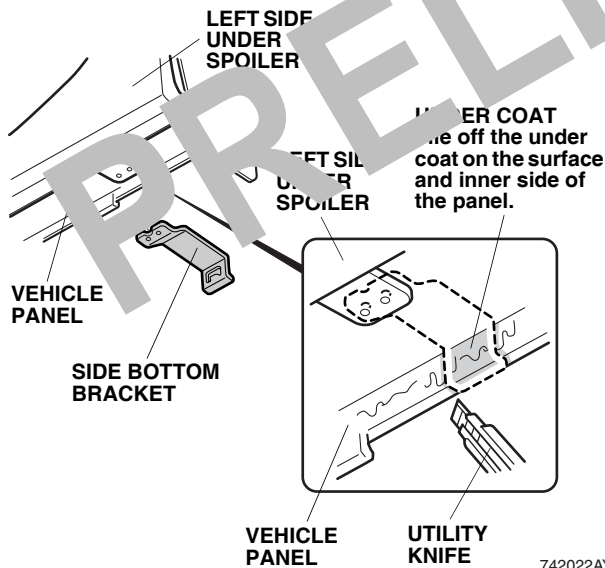

742022AY

18. Attach masking tape to the end of each adhesive backing. Fold the ends back, and tape them to the front of the left side under spoiler.

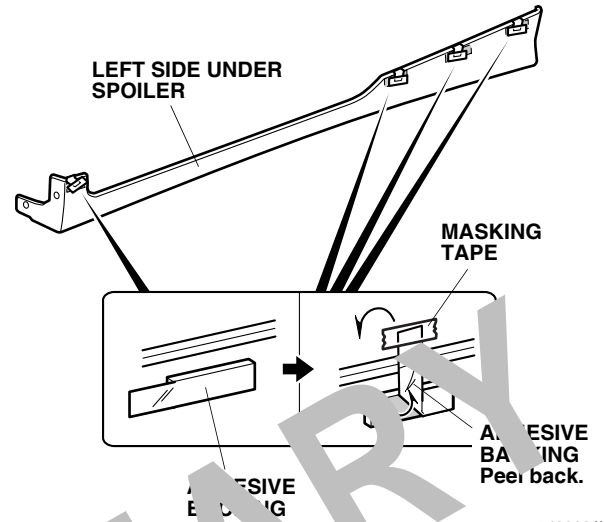

742023AY

19. Check the position of the under spoiler attachments by looking down from the top. Slide the left side under spoiler rearward slightly while pushing it against the vehicle body with both hands.
- Make sure the side lower bracket installation plates (upper and lower) attach to the brackets of the left side under spoiler.
 - Install the left side under spoiler very carefully. Excess pressure may damage the lower side bracket.
 - Check to see that the left side under spoiler bracket and side lower bracket are aligned if unable to install the left side under spoiler.

20. Check that all six brackets of the left side under spoiler are set in the side lower bracket installation plates.
- Visually check that there is no excessive gap between the left under spoiler and the vehicle. If an excessive gap is found, repeat operations from step 19.

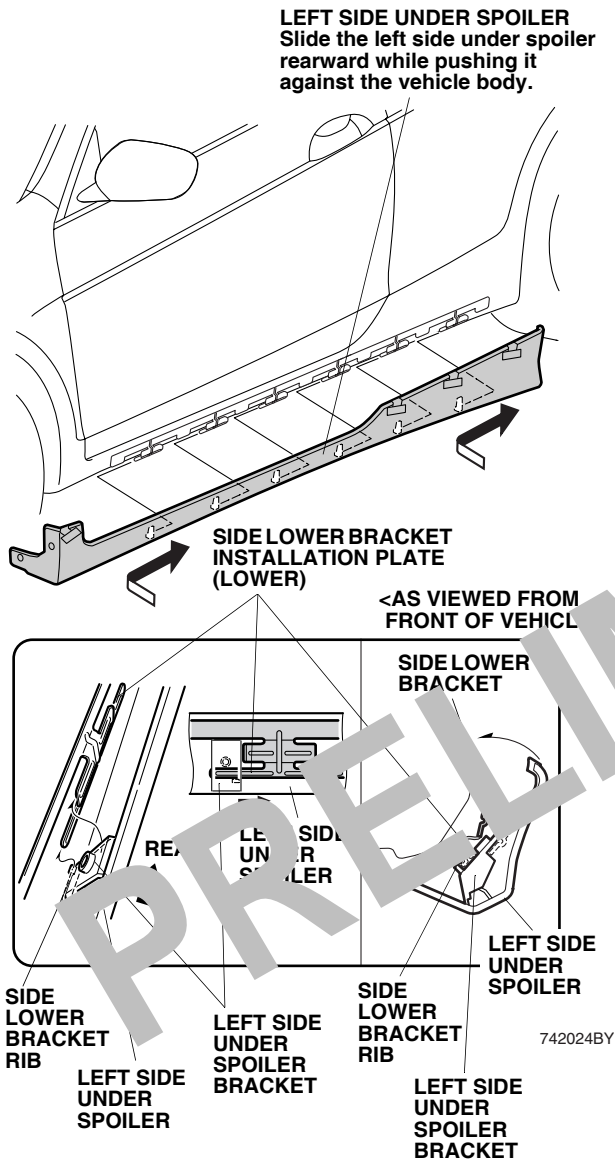

21. Gently tap on the left side under spoiler to remove any gap between the wheel arch of the left side under spoiler and the left front inner fender.

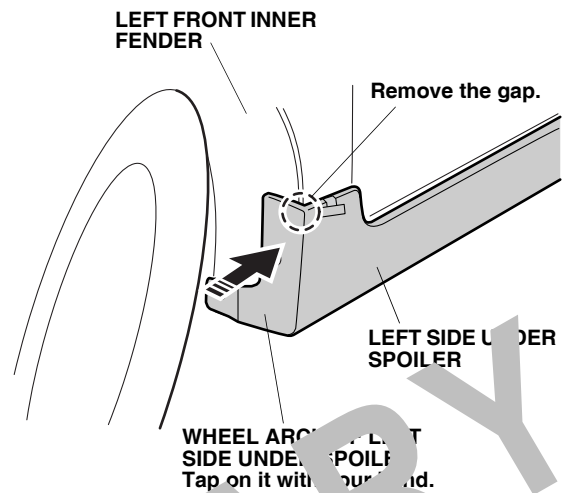

22. Loosely install the two 5 x 18 mm self-tapping screws in the holes in the wheel arch of the left side under spoiler.

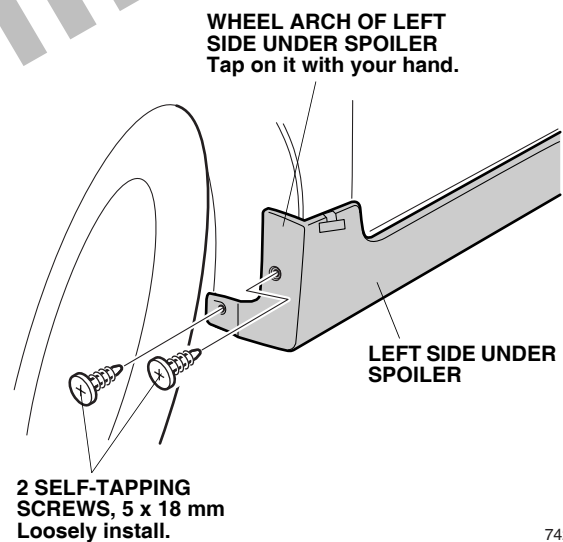

23. Loosen the clamp bolt with your hand. Do not use a wrench, as it can damage the bolt.
24. When the touch-up paint has dried, position the side under bracket and clamp on the side under spoiler. Loosely install the two screws. Thread the under clamp bolt, but don't tighten it completely yet.

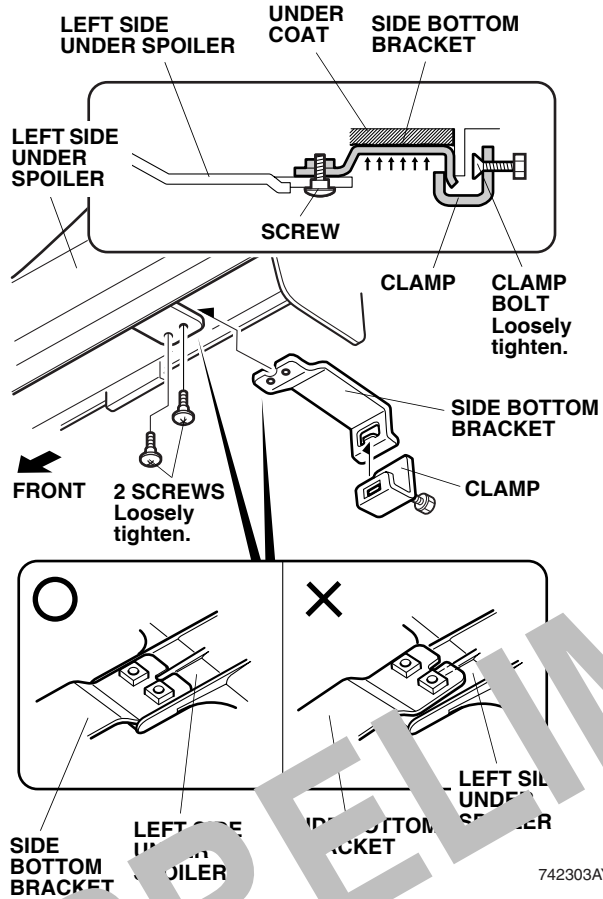

25. Remove the four adhesive backings from the left side under spoiler. Press on the adhesive part of the left side under spoiler firmly.
26. Tighten the two 5 x 18 mm self-tapping screws and the two screws securely.
27. Tighten the bolt on the clamp securely.
28. Repeat for the right side under spoiler.

