



INSTALLATION INSTRUCTIONS

Accessory

GOLD EMBLEMS
P/N 08F20-SJC-100

Application

2007 RIDGELINE

Publications No.

All 32430

Issue Date

MAY 2006

PARTS LIST

Front gold "H" emblem

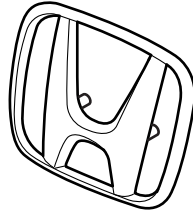

Rear gold "HONDA" emblem

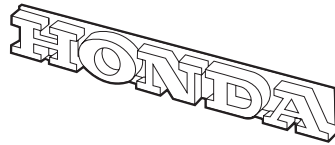

Rear gold "RIDGELINE" emblem

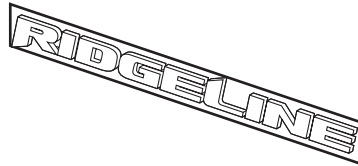

Rear gold "4WD" emblem



TOOLS AND SUPPLIES REQUIRED

- Phillips screwdriver
- Flat-tip screwdriver
- Ratchet
- 10 mm Socket
- Blanket
- Kite string
- Isopropyl alcohol

INSTALLATION

Customer Information: The information in this installation instruction is intended for use only by skilled technicians who have the proper tools, equipment, and training to correctly and safely add equipment to your vehicle. These procedures should not be attempted by "do-it-yourselfers."

NOTE:

- Be careful not to damage the body finish.
- To prevent damage, rest the front bumper on a blanket during the installation.
- This gold emblem kit should be installed only if the ambient air temperature is above 60°F (15°C).
- To allow the adhesive to "cure," do not wash the vehicle for 24 hours.

Installing the Front Gold "H" Emblem

1. Open the hood, then remove the front bumper (seven clips, four bolts, two short step bolts and two self-tapping screws). Place the front bumper on a blanket.

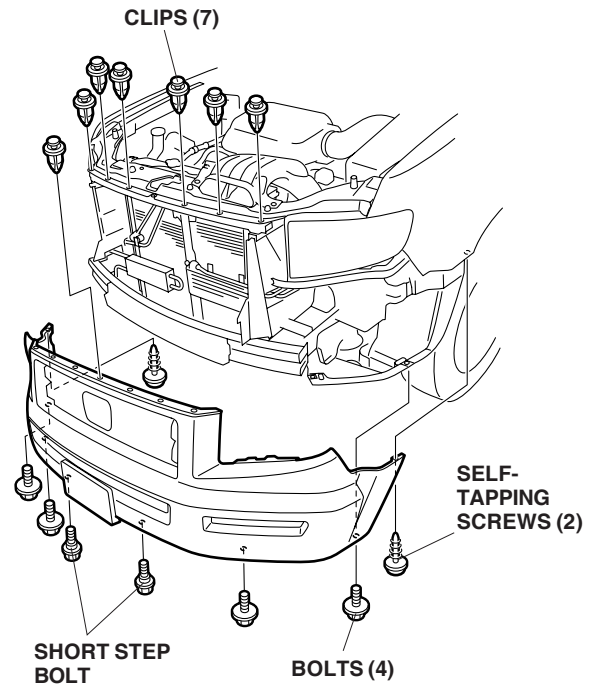

- Remove the front grille (nine self-tapping screws and eight tabs).

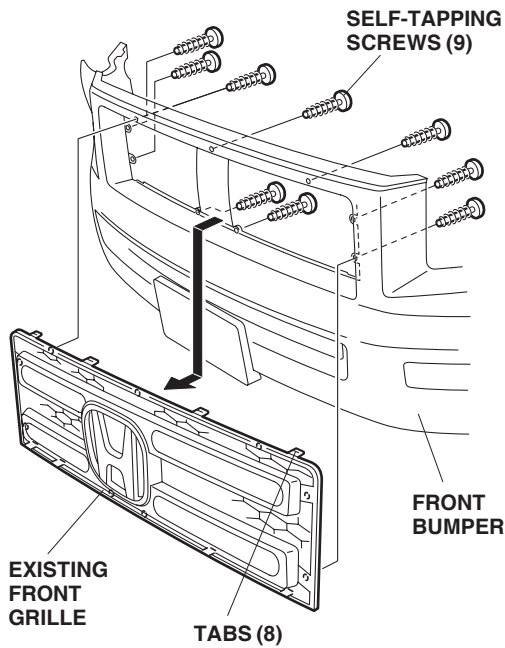

- Remove the two self-tapping screws that secure the existing "H" emblem and remove the emblem.

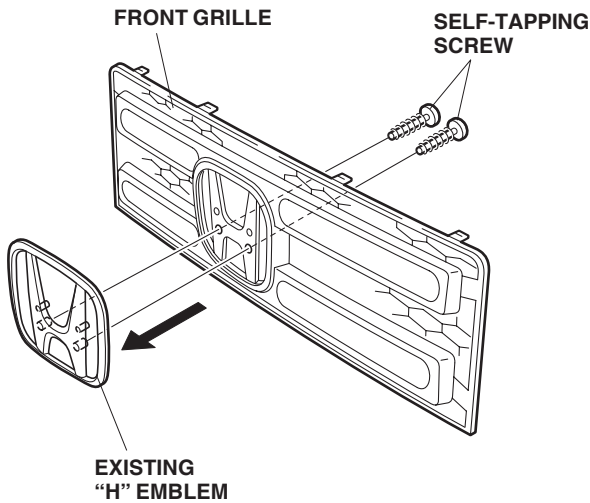

- Slide the pins on the front gold "H" emblem into the holes in the emblem base, and install the two self-tapping screws you just removed.

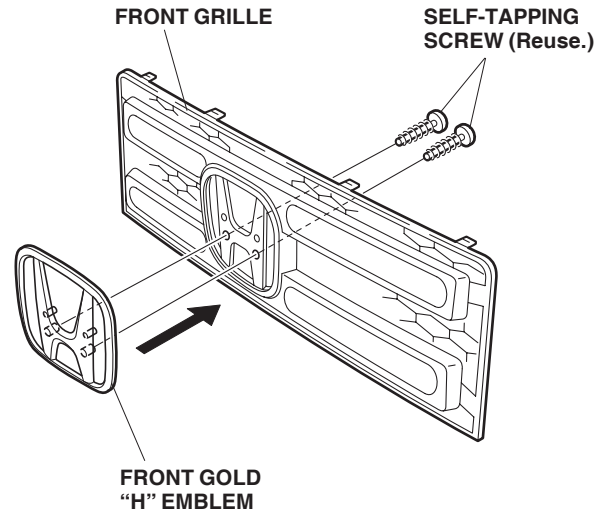

- Reinstall all removed parts. Check that all retaining pawls and clips are installed properly without play or rattle.

Installing the Rear Gold "HONDA," "RIDGELINE," and "4WD" Emblems

- Mark the locations of the existing "HONDA," "RIDGELINE," and "4WD" emblems by applying masking tape along four edges as shown.

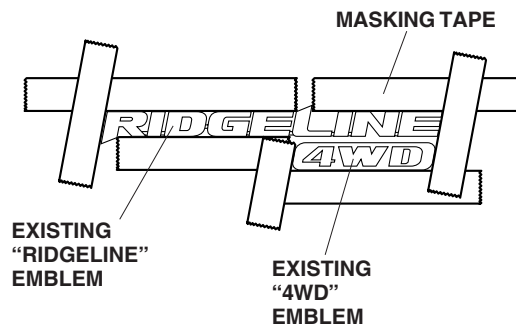
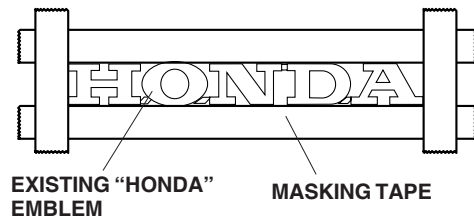

- Remove the "HONDA," "RIDGELINE," and "4WD" emblems from the body by moving a piece of kite string between the emblems and body.

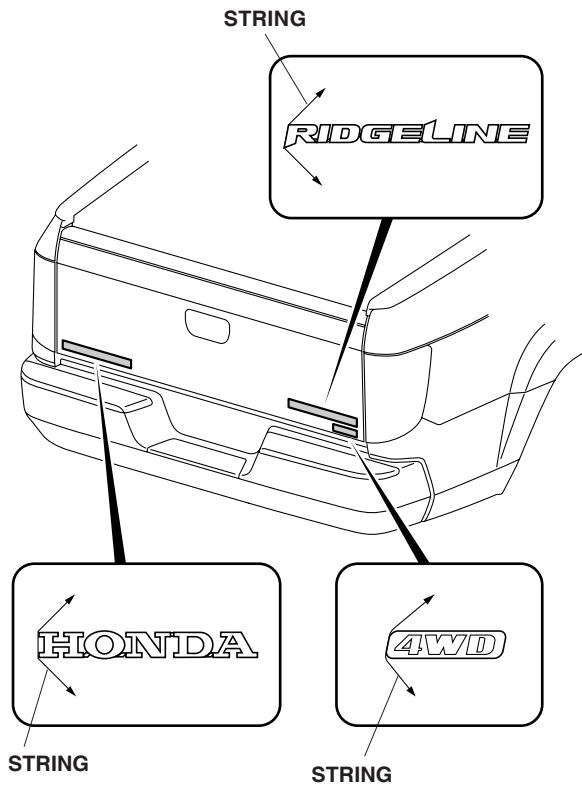

- Using isopropyl alcohol on a shop towel, clean the areas where the rear gold "HONDA," "RIDGELINE," and "4WD" emblems will attach.

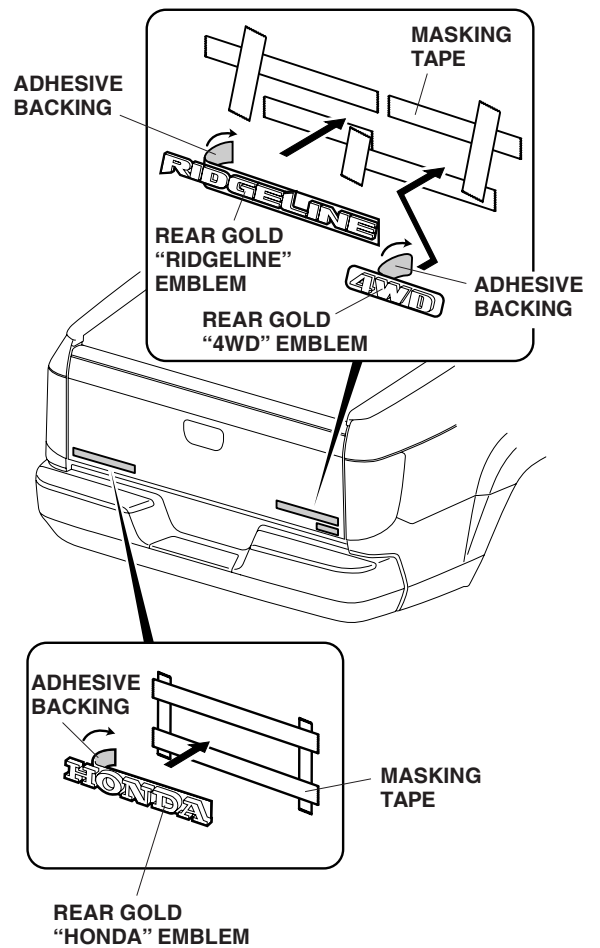

- Remove the adhesive backing from the "HONDA," "RIDGELINE," and "4WD" emblems and attach them to the body. After attaching, hold the emblems firmly against the body with the palm of your hand for 30 seconds.
- Remove the masking tape.