



INSTALLATION INSTRUCTIONS

Accessory

SKI ATTACHMENT
P/N 08L03-TA1-100B

Application

2007 ODYSSEY

Publications No.

All 33188

Issue Date

JULY 2006

Put this information in the glove box with the vehicle owner's manual.

PARTS LIST

2 Ski attachments

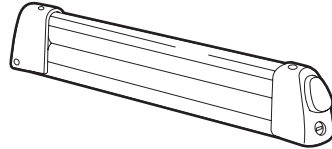

4 Knobs



4 Short T-bolts (for removable rack)

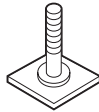

4 Long T-bolts (for fixed rack)

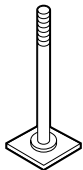

4 Spacers (for fixed rack)

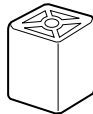

Key



TOOLS REQUIRED

Phillips screwdriver

T30 TORX Bit

Ratchet

INSTALLATION

NOTE:

- The ski attachments are designed to be used exclusively with a Honda roof rack, which is sold separately. If the vehicle is not equipped with a roof rack, have the recommended roof rack on hand and install the roof rack before installing the ski attachment.
- The ski attachments may be installed either with both on the driver's side or with both on the passenger's side.

- If equipped, remove the roof rack crossbars and end caps. Remove the four TORX bolts, four lock washers, and four washers from the front and rear crossbars, then remove the crossbars. Remove the four TORX self-tapping screws and eight washers from the crossbars, then remove the caps.

Odyssey (EX):

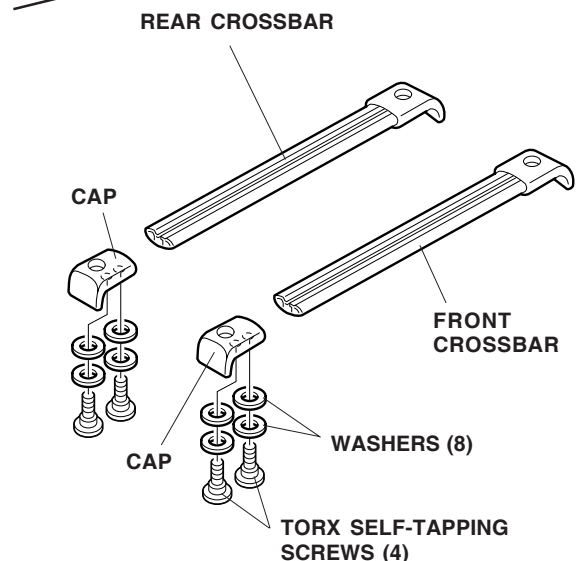
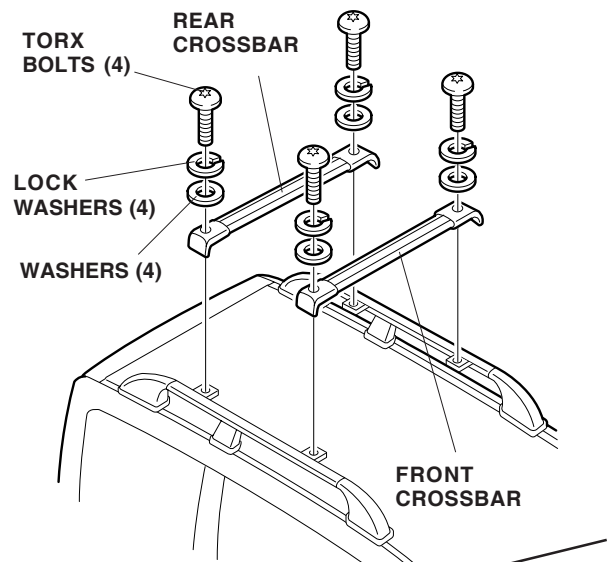

- If equipped, remove the right roof rack side rail. Remove the six screws from the right side rail, then remove the four self-tapping Torx screws and washers, and remove the side rail.

Odyssey (LX):

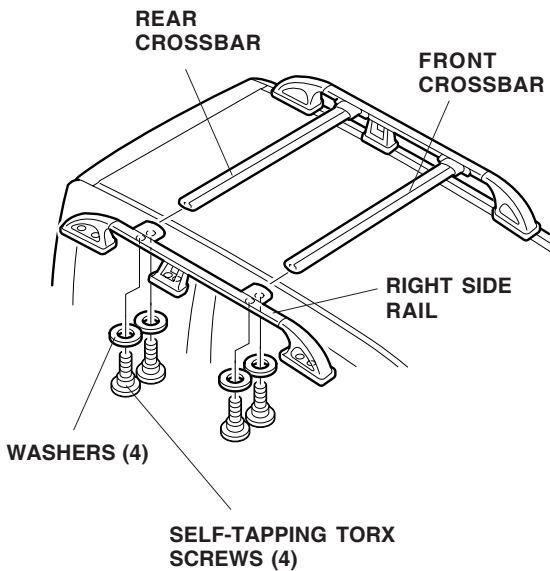
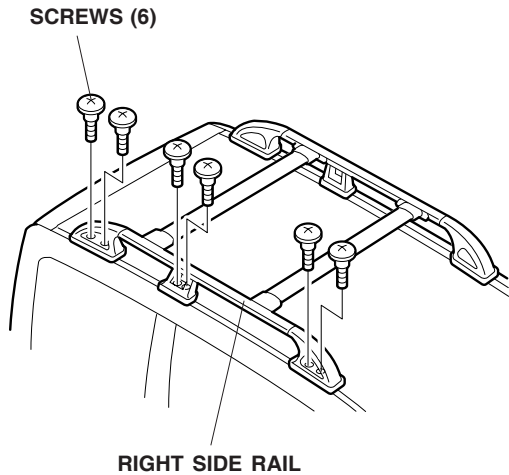

- Remove the rubber moldings from the front and rear roof rack crossbars. Retain the rubber moldings to reinstall later.

Odyssey (EX):

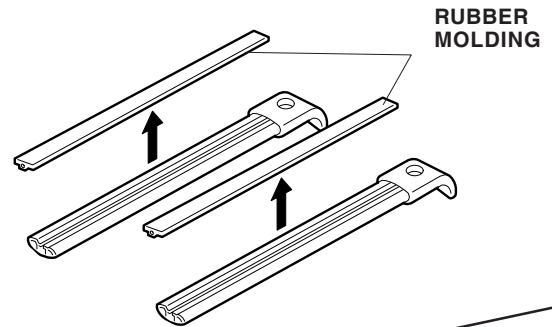

Odyssey (LX):

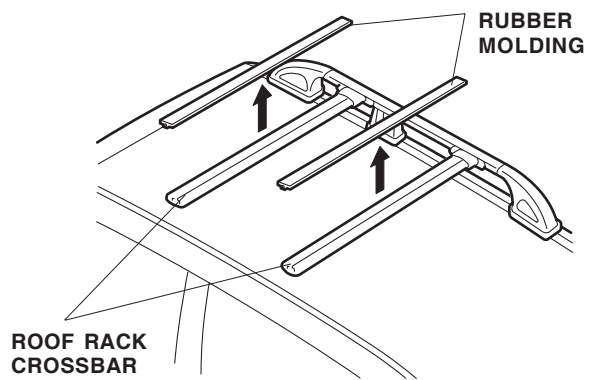

- Slide the two long bolts into each crossbar.

Odyssey (EX):

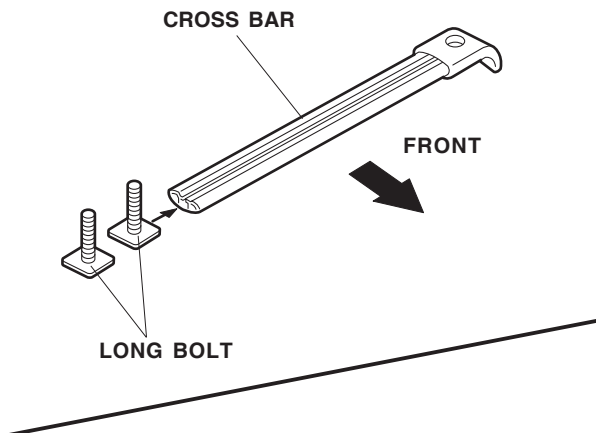

Odyssey (LX):

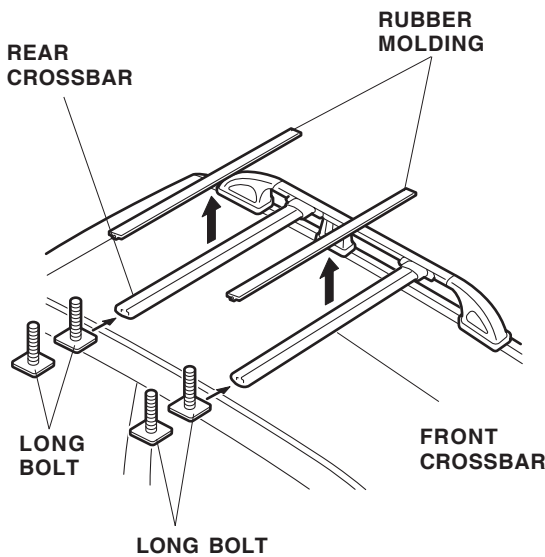

- Reinstall the right side rail to the crossbars (if equipped), and torque the screws to 5 to 7 lb-ft (7 to 10 N·m). Reinstall the caps and crossbars (if equipped), and torque the TORX bolts to 7 lb-ft (10 N·m). Reinstall the roof rack cover (if equipped).

- Insert the key, and turn it clockwise to unlock the front ski attachment. Press the button, and open the top frame completely.

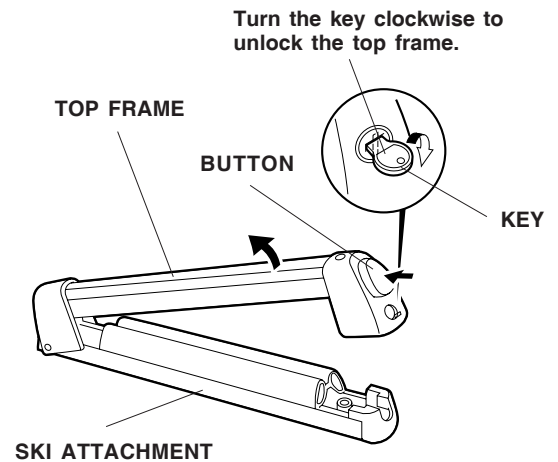

- Position the spacers and the front ski attachment onto the T-bolts, and install the two knobs. Tighten the knobs securely.

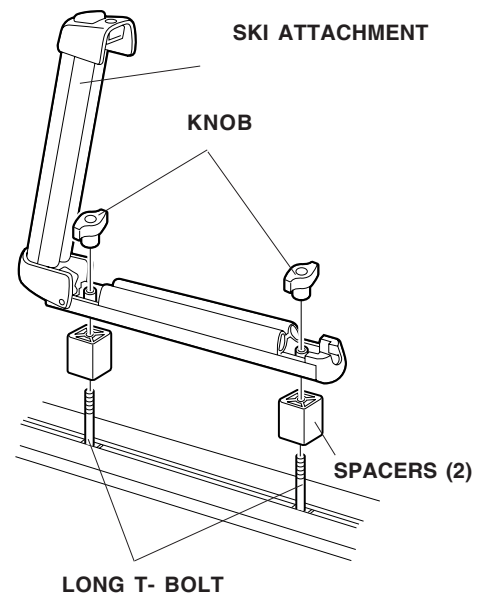

- Repeat steps 6 and 7 to install a ski attachment to rear crossbar.
- Close the top frame and listen for it to "click" into position, then turn the key counterclockwise to lock the top frame.
- Rock the ski attachment in all directions to make sure it is installed securely. If necessary, retighten the T-bolts or reinstall the ski attachment.

- To prevent excess wind noise, cut each rubber molding and install the cut pieces into the grooves in the crossbars.

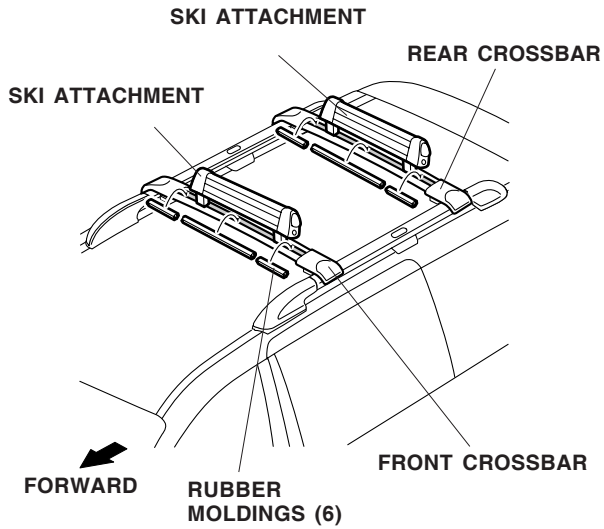

- Write down the key number, and put it in a safe place in case the key is lost or stolen.

Loading the Skis on the Vehicle

- Insert the key, and turn it clockwise to unlock the top frame. Push the button, and raise the top frame completely.

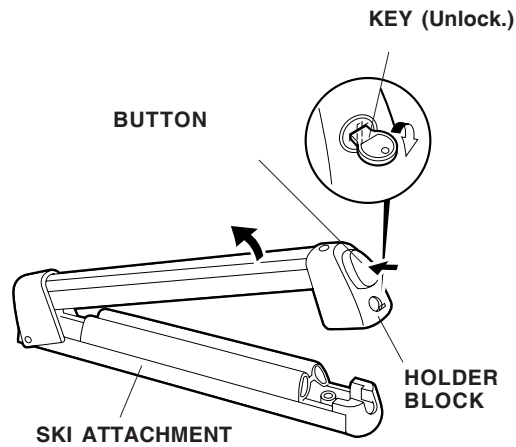

- Position the skis on the attachment with the rear of the skis facing forward, and the bindings between the front and rear attachments.

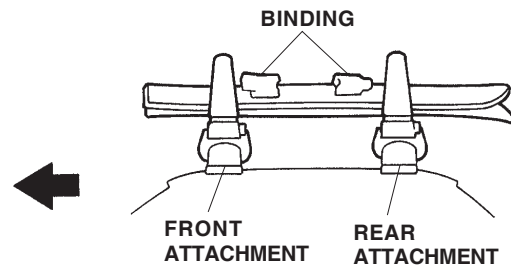

- If the bindings cannot be positioned between the front and rear attachments, install the skis with one of the bindings positioned behind the rear attachment.

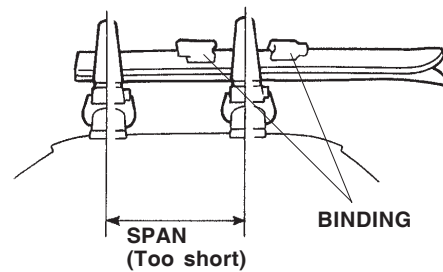

- Close the top frame, and listen for it to "click" into position. Depending on the thickness of the ski, you may need to attach the hook in the second position.

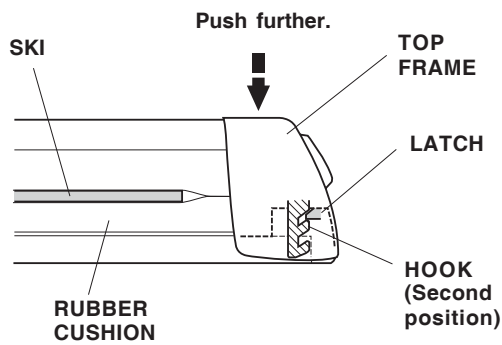
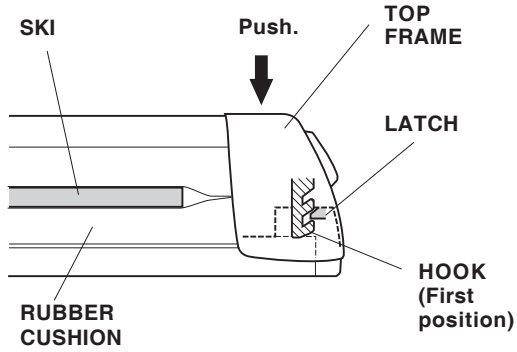

- Lock the top frame by turning the key counterclockwise. Remove the key.

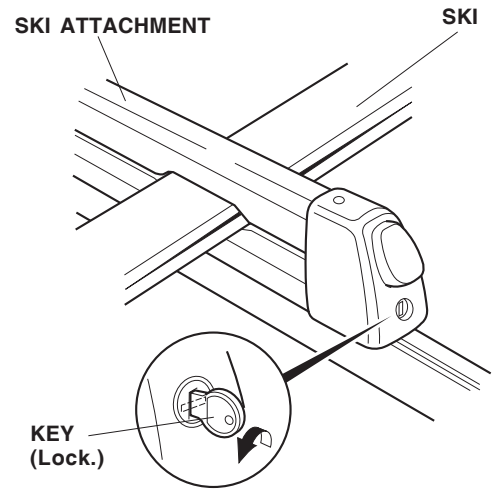

- With the ski attached, rock the attachment in all directions to make sure it is installed securely. Adjust as necessary.

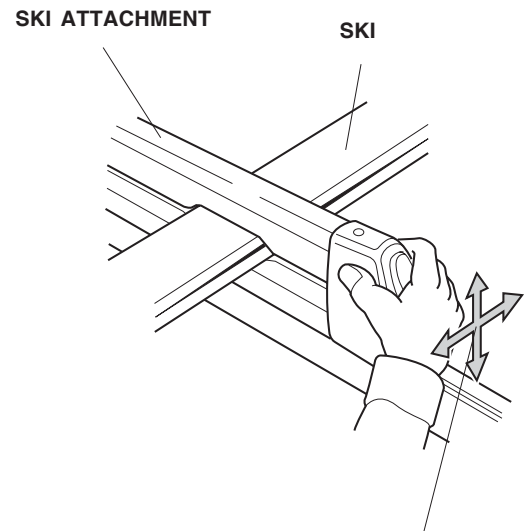

Rock the ski attachment in all directions to make sure it is installed securely.