



INSTALLATION INSTRUCTIONS

Accessory
ROOF RACK CROSSBAR (LX)
P/N 08L02-SHJ-100A

Application
2007 ODYSSEY

Publications No.
All 33183
Issue Date
JULY 2006

PARTS LIST

Front crossbar
(longer)

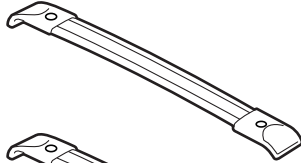

Rear crossbar
(shorter)

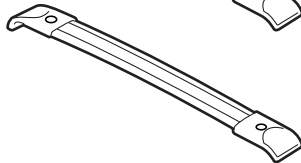

4 Special bolts

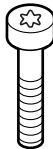

Right side rail

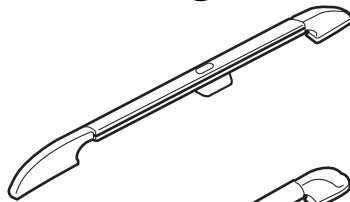

Left side rail

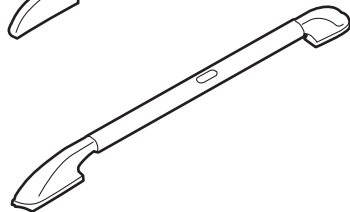

4 Short TORX bolts



Right center stay

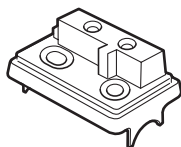

Left center stay

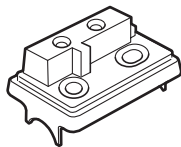

Right center cover

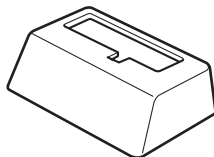

Left center cover

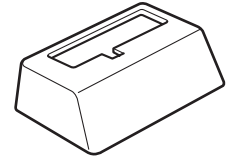

4 Holders

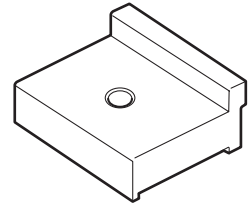

12 TORX nuts



2 Rail caps

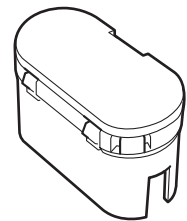

4 Washers



4 Lock washers



TOOLS AND SUPPLIES REQUIRED

Phillips screwdriver

Flat-tip screwdriver

Shop towel

Long-nose pliers

T-30 TORX driver

Hacksaw (32 tpi blade)

Small flat-tip screwdriver

INSTALLATION

NOTE:

- The weight of cargo must not exceed the maximum weight capacity of 150 lb (68 kg).
- Be extremely careful not to damage the roof and other finished surfaces of the body when installing the roof rack.
- Do not interchange the front and rear parts or the right and left parts.

1. Place a shop towel around the tip of a flat-tip screwdriver, and pry up on the rear of each roof molding.

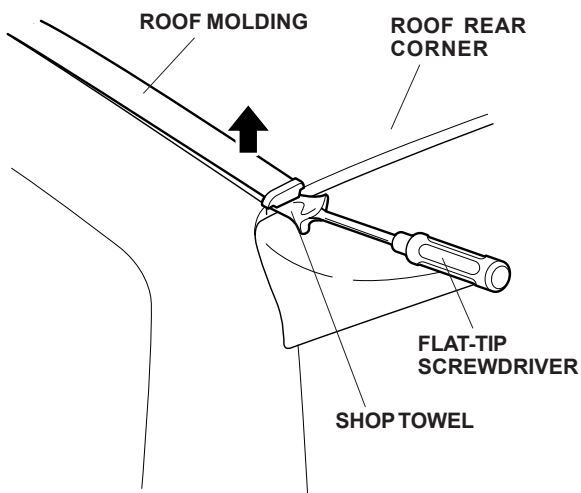

2. Remove the roof moldings by carefully lifting them upward.

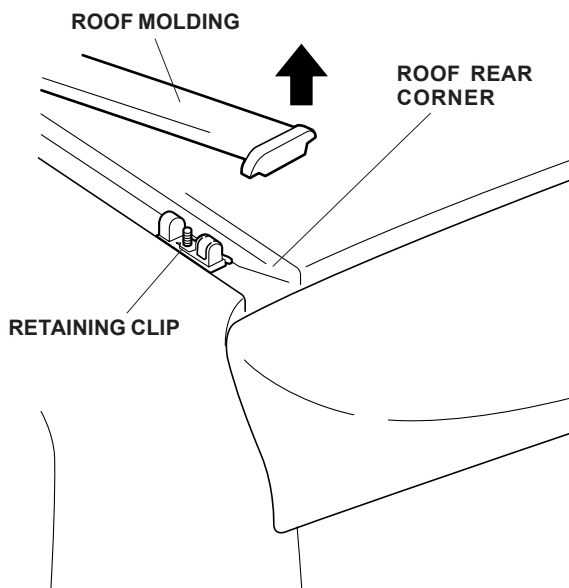

3. If the front or rear retaining clips remained on the roof molding, remove them from the roof molding, and reinstall them in their original positions on the vehicle. Remove the remaining clips and set them aside; they will not be reused.

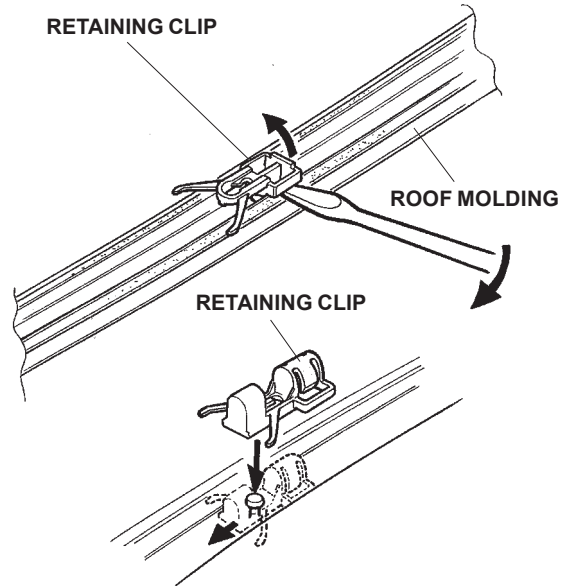

4. If any of the six center retaining clips remained on the roof, remove them from the stud bolts using long nose pliers.

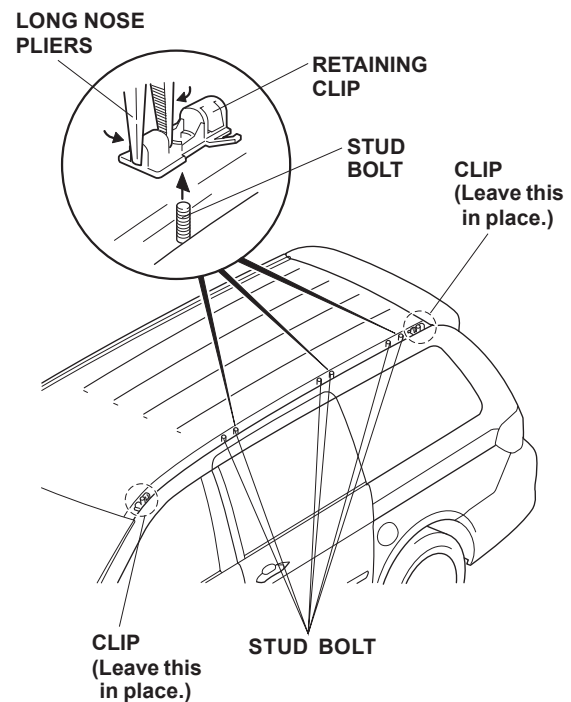

- Using a hacksaw, cut each roof molding according to the dimensions shown.

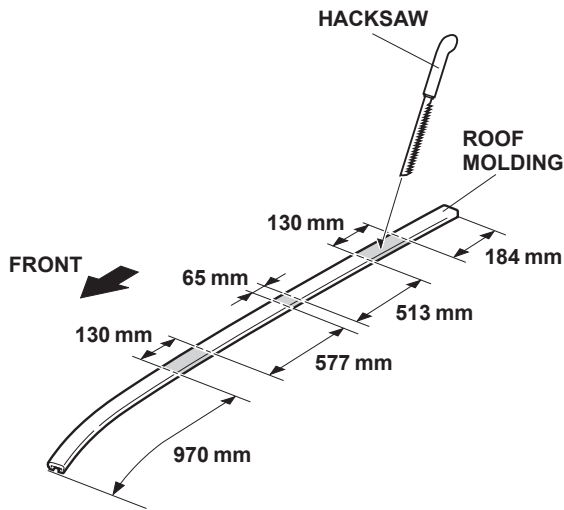

- Reinstall the cut pieces of molding to the vehicle.

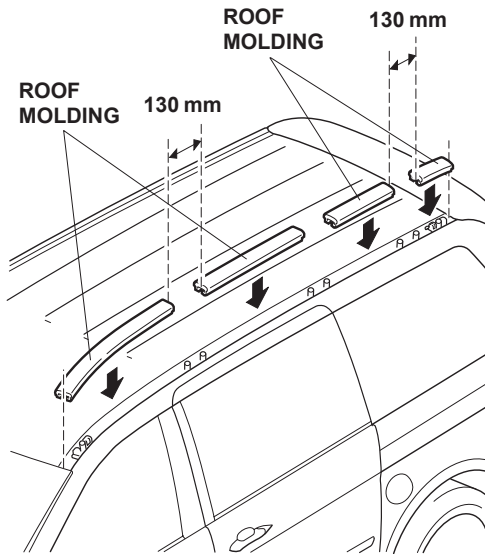

- Place the left center stay over the two stud bolts at the center of the roof, and install the two TORX nuts using a T-30 TORX driver. Torque the TORX bolts to 5 to 8 lb-ft. (7 to 10 N·m).

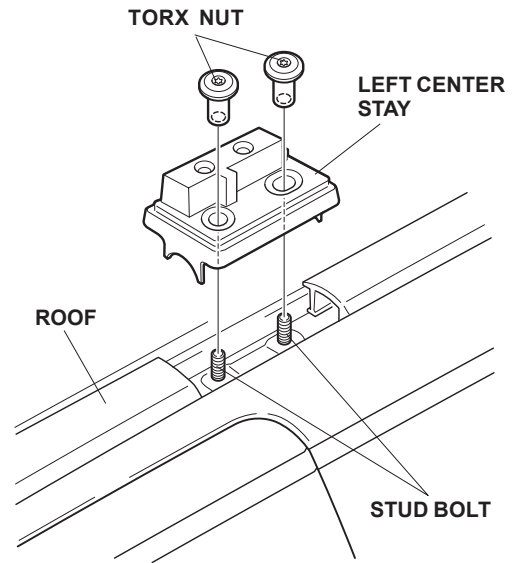

- Install the left center stay cover on the left center stay.

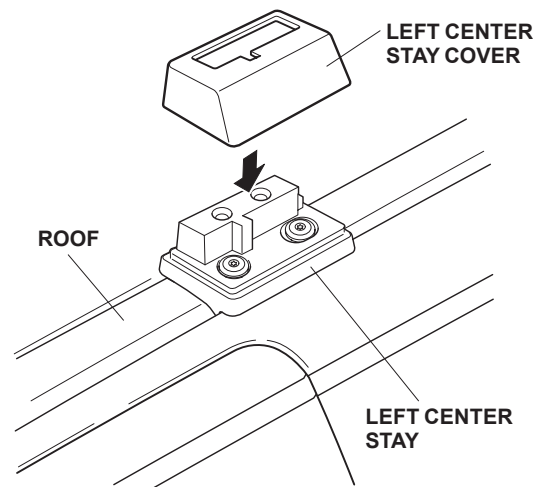

9. Place the left roof rail over the four stud bolts on the left side of the roof.

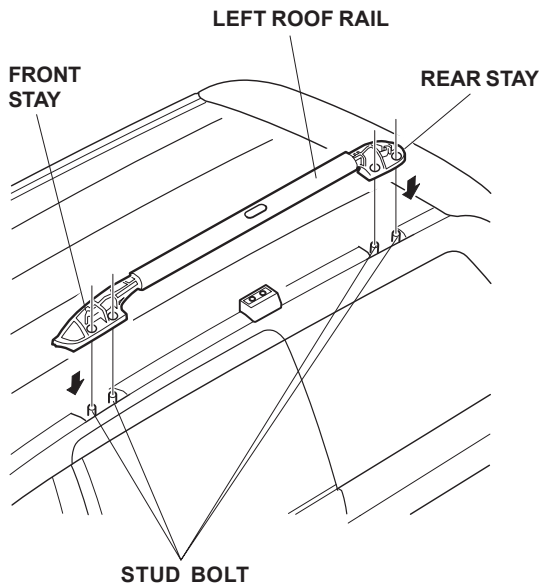

10. At the center stay, install two short TORX bolts through the holes in the left roof rail. Torque these TORX bolts to 4 to 5 lbs (5 to 7 N·m).

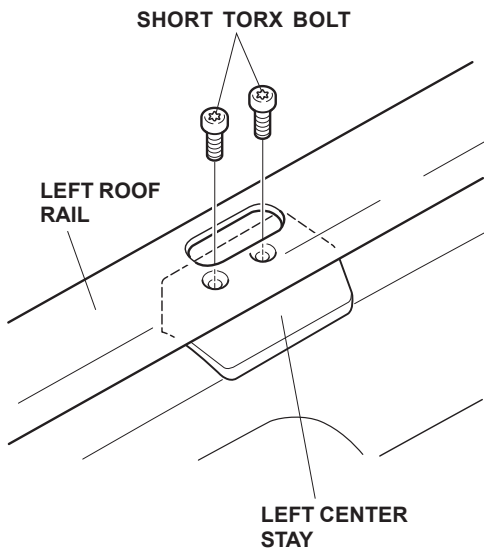

11. Install four TORX nuts to the stud bolts in the front stay and the rear stay. Torque the four TORX nuts to 5 to 8 lb-ft. (7 to 10 N·m).

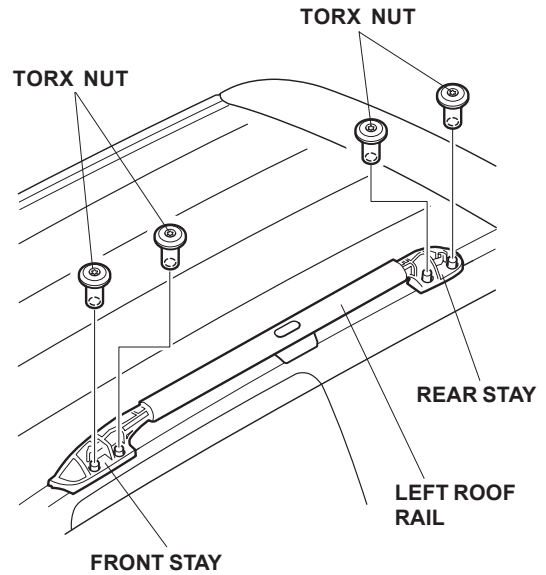

12. Install the rail cap into the hole in the center of the left roof rail.

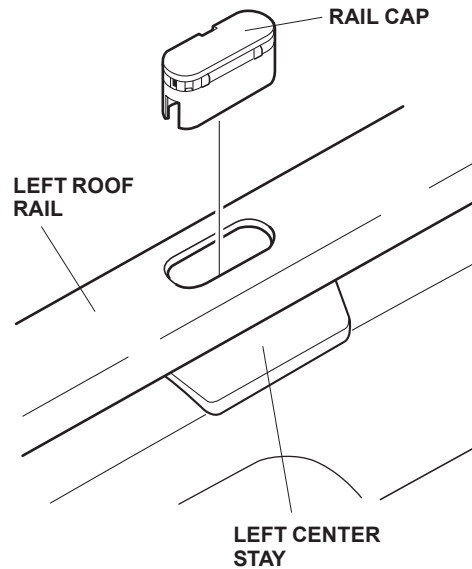

13. Repeat steps 7 through 12 to install the right roof rail on the right side of the vehicle.

- Slide two holders into each roof rail from the rear of each rail.

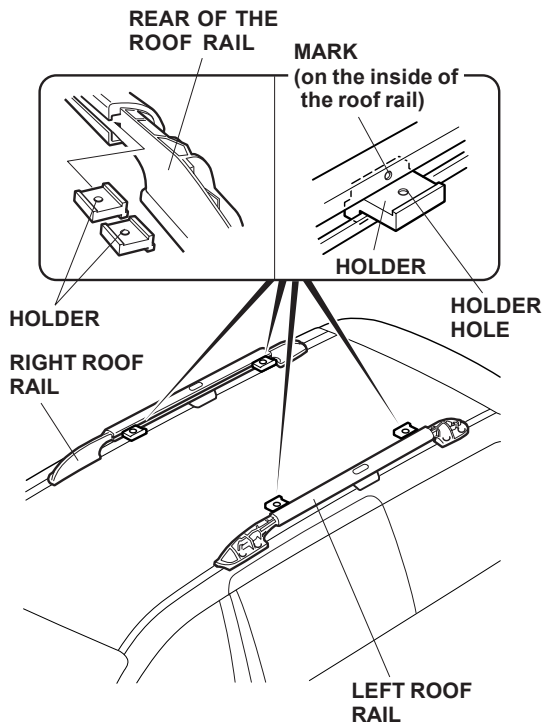

- Align the hole in each holder with the mark on the inside of the roof rail.
- Position the cross bars on the holders, and install the special bolts with washers. Tighten the bolts securely.

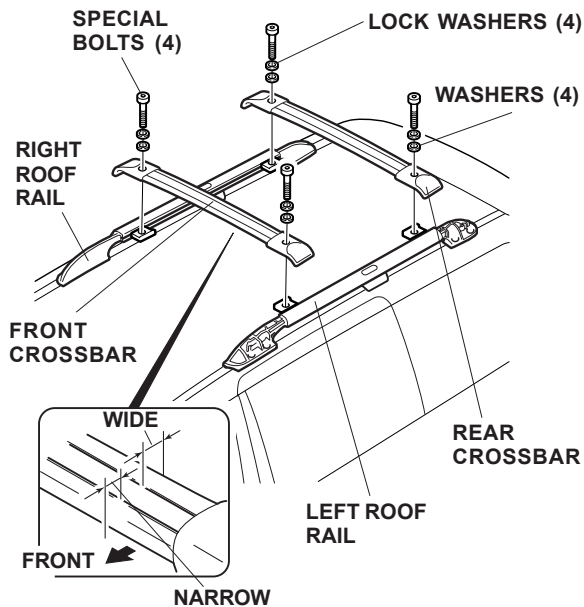

- Install the stay covers to the roof rail.

