



# INSTALLATION INSTRUCTIONS

Accessory  
**REAR UNDER SPOILER**

Application  
**2007 ODYSSEY**

Publications No.  
**All 33181**  
Issue Date  
**JULY 2006**

**NOTE: Optional splash guards cannot be used with this rear with this rear under spoiler.**

## PARTS LIST

Rear under spoiler

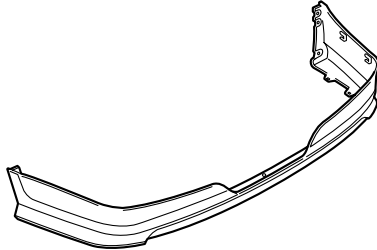

5 Long Stepped bolts



4 Short Stepped bolts



6 Square head bolts

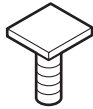

2 Self-tapping screws

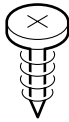

15 Washer-nuts



2 Spring nuts



4 Adhesive Collars



## TOOLS AND SUPPLIES REQUIRED

Phillips screwdriver

Flat-tip screwdriver

Ratchet

10 mm Socket

Drill

3 mm, 8 mm, and 10 mm Drill bits

Clip remover

Felt-tip pen

File

Isopropyl alcohol

Shop towel

Masking tape

Blanket

Pushpin

Eye protection (face shield, safety goggles, etc.)

## INSTALLATION

**Customer Information:** The information in this installation instruction is intended for use only by skilled technicians who have the proper tools, equipment, and training to correctly and safely add equipment to your vehicle. These procedures should not be attempted by "do-it-yourselfers."

### NOTE:

- Be careful not to damage the rear bumper and body paint finish.
- To prevent damage, rest the rear bumper on the blanket during the installation.
- This rear under spoiler kit should be installed only if the ambient air temperature is 60°F (15°C) or above.
- To allow the adhesive to "cure", do not wash the vehicle for 24 hours.

- Remove the rear bumper:
  - If equipped, remove two screws and three clips that secure the inner fender.
  - Remove the four self-tapping screws (two on each side) at the fenderwell.
  - Using a clip remover, pry out and remove the three clips along the bottom of the bumper.
  - Using a flat-tip screwdriver, pry out and remove the bumper bolt cover covers, then remove the four bumper bolts.
  - With the help of an assistant, release the bumper from the fenderwell, and slide the bumper away from the vehicle.
  - If equipped, unplug the backup sensor connectors.
  - Set the bumper on a blanket.

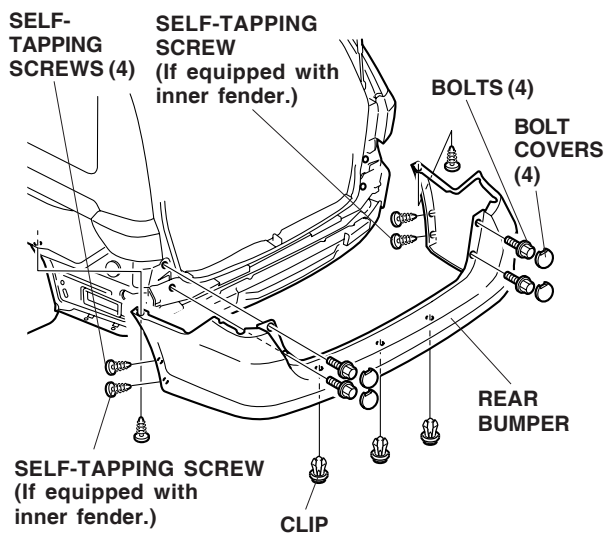

- On the inside of the bumper, locate the 13 marked areas. Using a pushpin, pierce the bumper at the 13 locations identified below. Double-check your marks before piercing through the bumper.
  - 3.

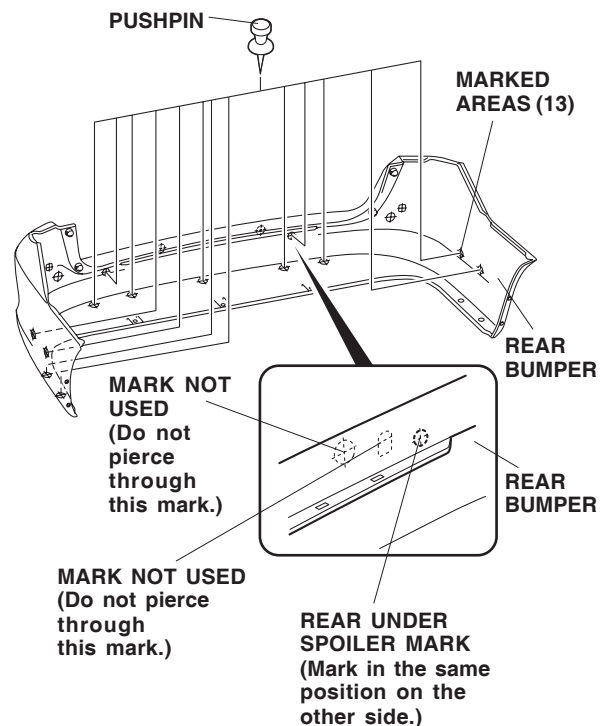

- While wearing eye protection, drill an 8 mm hole through the two rear marks and the four side marks.
  - First drill with a 3 mm drill bit, then finish with an 8 mm drill bit.
  - Remove any burrs from the edges of the holes with a file.

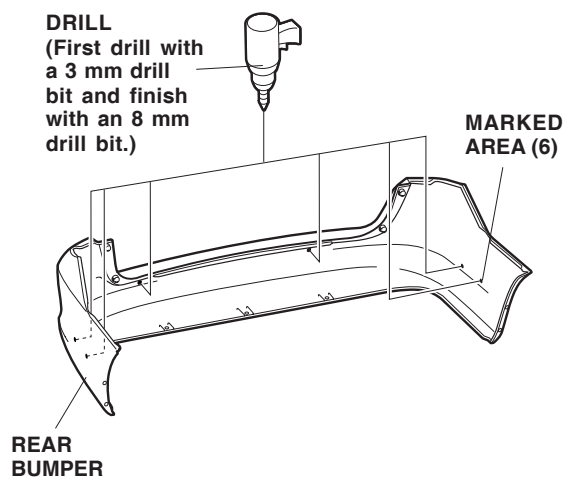

4. Turn the bumper upside down. While wearing eye protection, drill a 10 mm hole through each of the seven marks and two slots:
  - First drill with a 3 mm drill bit, then finish with a 10 mm drill bit.
  - Remove any burrs from the edges of the holes with a file.

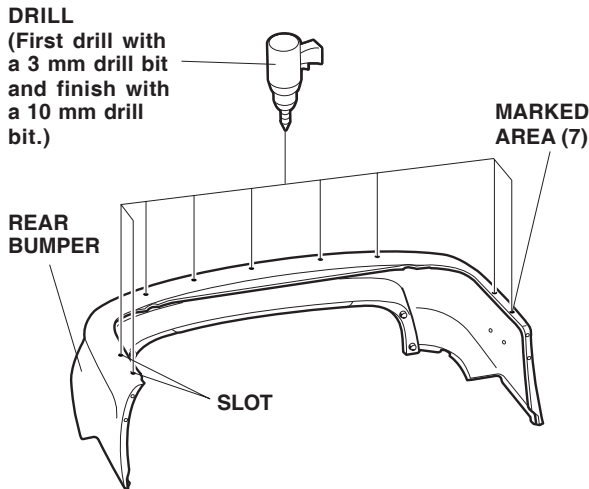

5. On the inside of the rear under spoiler, locate the six brackets (three on each side). Slide one square head bolt into each bracket on the rear under spoiler.

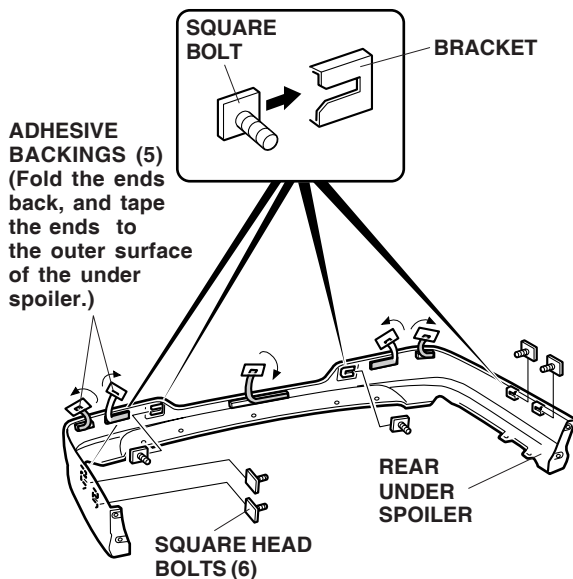

6. Attach a strip of masking tape to the end of each adhesive backing, then pull back 1½ to 2 inches of adhesive backing. Fold the ends back, and tape them to the outer surface of the spoiler with masking tape.

7. Using isopropyl alcohol on a shop towel, clean the rear spoiler areas where the adhesive collars will attach. Remove the adhesive backing from each adhesive collar, and attach the collar to the inside of the rear spoiler in the areas shown.

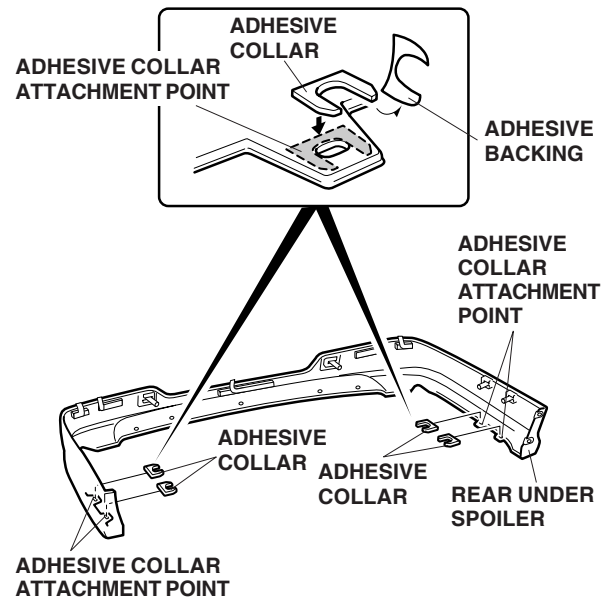

8. LX model only: Install one spring nut to the lower bumper hole on each side at the fenderwell.

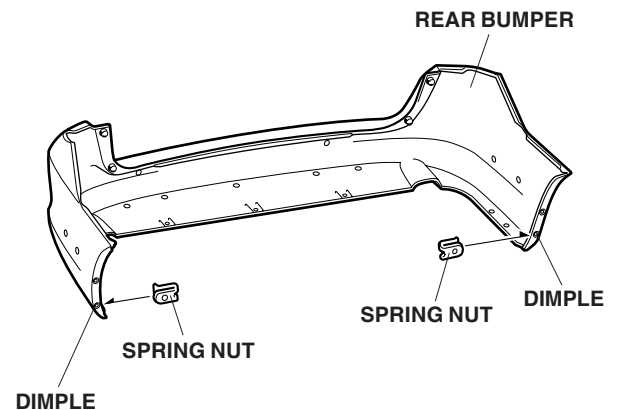

9. Using isopropyl alcohol on a shop towel, clean the rear bumper where the rear under spoiler will attach.

10. Position the rear under spoiler on the rear bumper, and install a washer nut to each square-head bolt. Tighten the washer-nuts in the order shown.

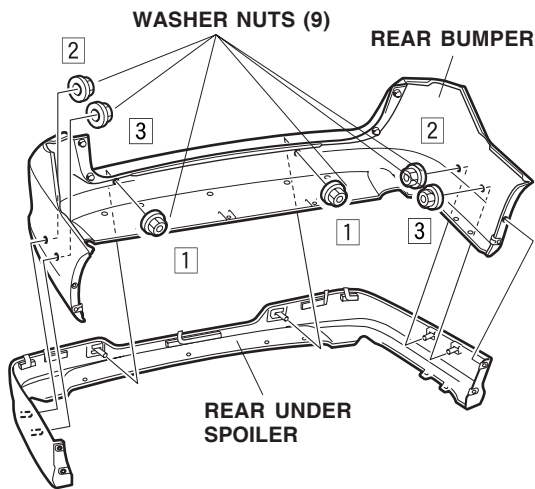

11. Install the five long stepped bolts through the inboard holes in the under spoiler, and install the four short stepped bolts through the outboard holes in the under spoiler. Install a washer-nut on each stepped bolt. Tighten the washer-nuts in the order shown.

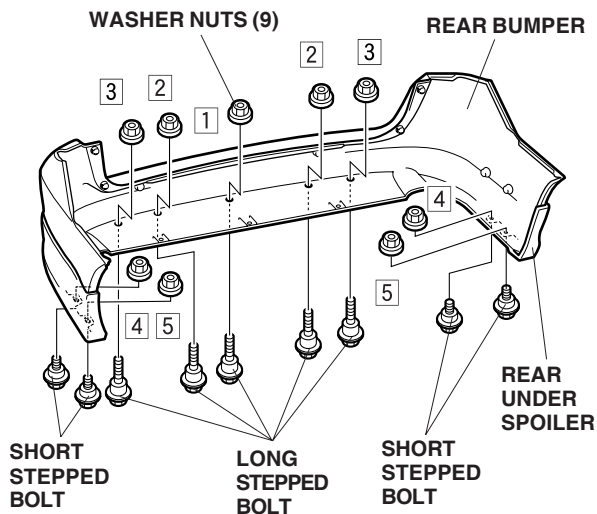

12. While holding light pressure on the under spoiler, carefully remove the adhesive backings from the under spoiler. After attaching, hold the under spoiler firmly against the rear bumper with the palm of your hand for 30 seconds, particularly at the edges.

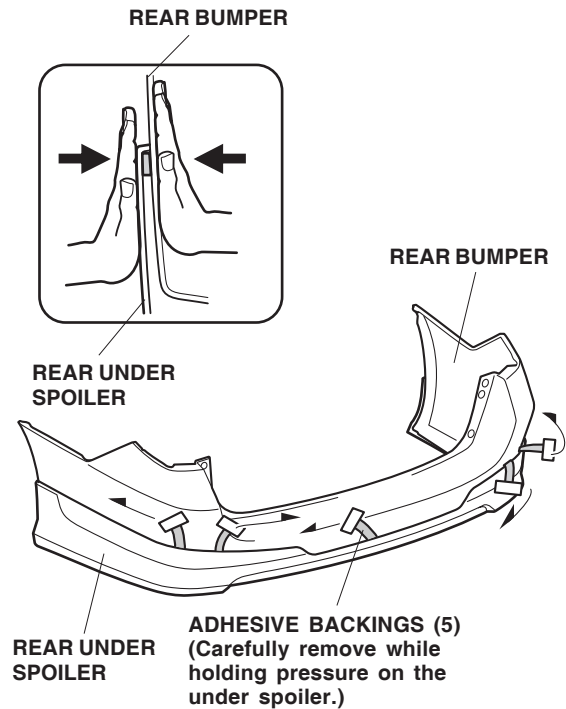

13. Reinstall the rear bumper.

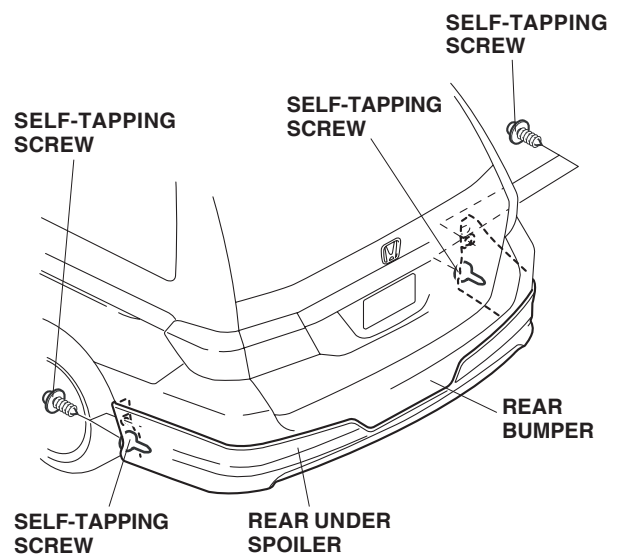

14. Install the self-tapping screws at the fenderwell.

**Give a copy of this page to your customer.**

- When towing the Odyssey, follow the instructions described in the vehicle Owner's Manual.
- When using the rear towing hook, make sure to remove the rear bumper with rear under spoiler. Failure to follow this precaution could damage the vehicle, the rear bumper, and the rear spoiler.

