



INSTALLATION INSTRUCTIONS

Accessory

FRONT GRILLE
P/N 08F21-SLN-100A

Application

2007 FIT

Publications No.

All 31715

Issue Date

MAR 2006

PARTS LIST

Front grille

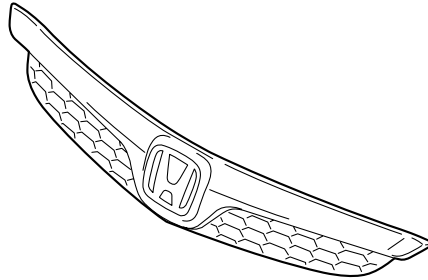

TOOLS AND SUPPLIES REQUIRED

Phillips screwdriver
Flat-tip screwdriver
Isopropyl alcohol
Shop towel
Masking tape
Blanket

INSTALLATION

Customer Information: The information in this installation instruction is intended for use only by skilled technicians who have the proper tools, equipment, and training to correctly and safely add equipment to your vehicle. These procedures should not be attempted by "do-it-yourselfers."

NOTE: Be careful not to damage the body finish.

1. Open the hood, remove the eight clips and four screws that fasten the front bumper. With the help of an assistant, remove the front bumper. To prevent damage, set the front bumper on a blanket.

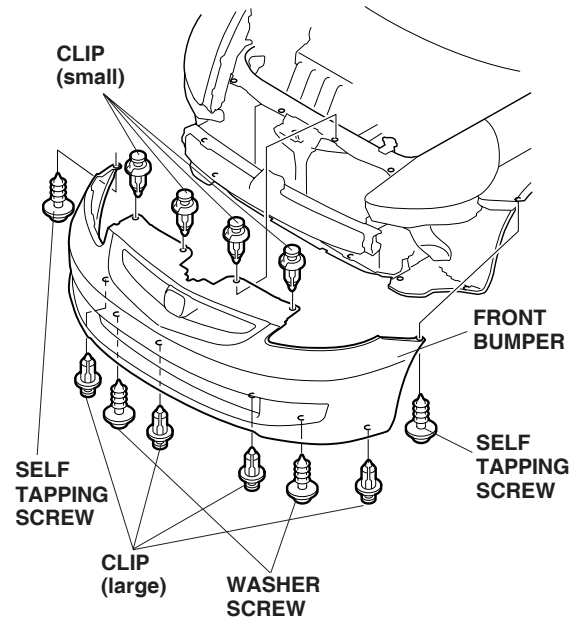

- Remove the two self-tapping screws and four retaining tabs that secure the top of the front grille. Remove the three retaining tabs that secure the bottom of the front grille and remove the front grille.

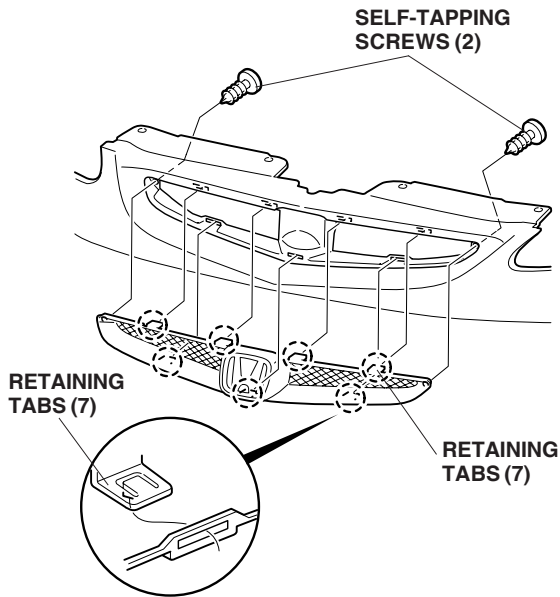

- Peel back 1-1/2 to 2 inches of the adhesive backing, and attach a strip of masking tape to the end of each adhesive backing. Fold the ends back, and tape them to the front of the front grille.

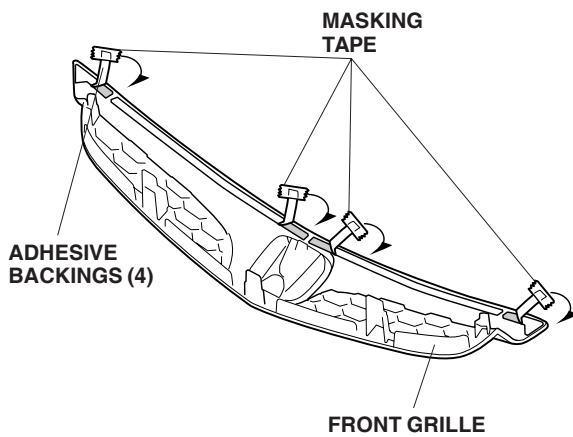

- Using isopropyl alcohol, thoroughly clean the surface of the front bumper where the front grille will attach.

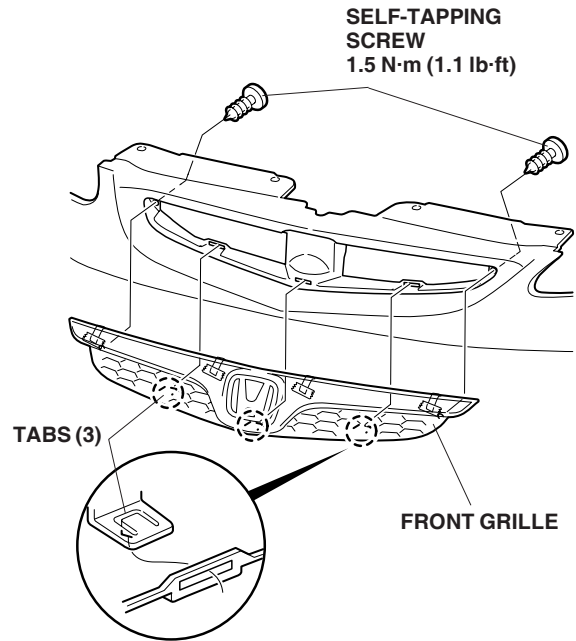

- Position the front grille on the front bumper by installing the three lower retaining tabs into the front bumper and reinstall the two self-tapping screws removed in step 2.

- Align the upper edge of the front grille with the upper edge of the front bumper by pushing down on the front grille, then while remove the adhesive backings, and use the palm of your hand to hold pressure against it for 30 seconds. Start from the center and work toward the sides.

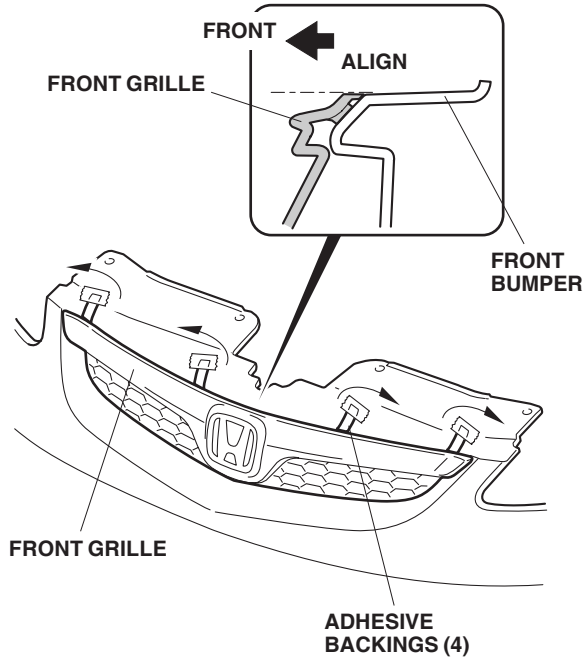

- Reinstall the front bumper.