



# INSTALLATION INSTRUCTIONS

Accessory

FOG LIGHTS

Application

2007 FIT

Publications No.

All 31723

Issue Date

MAR 2006

## PARTS LIST

Fog light assembly (left)

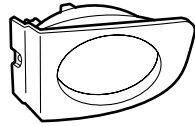

Fog light assembly (right)

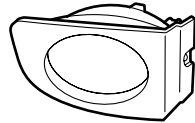

Fog light harness

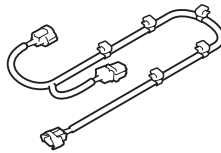

Switch harness

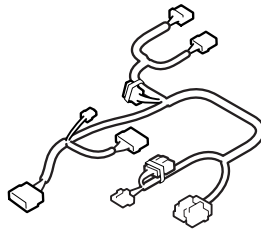

Fuse label

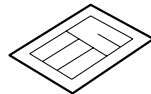

Relay

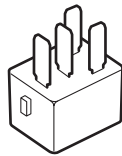

2 Clip nuts



2 Special screws

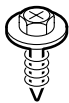

11 Wire ties

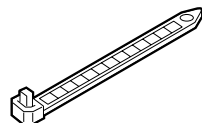

Fog light subharness

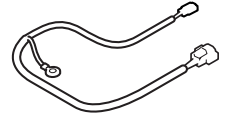

2 Wire ties with clips

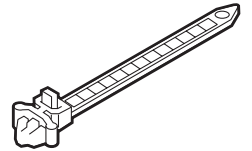

Fuse (20A)

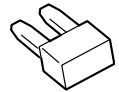

Template

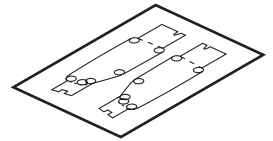

Fog light switch

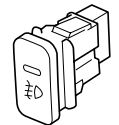

Wire tie with holder

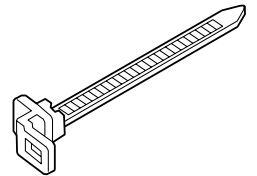

2 Clips



## TOOLS REQUIRED

Phillips screwdriver  
Flat-tip screwdriver  
Ratchet wrench (8 mm, 10 mm box)  
Drill  
Drill bits (3 mm, 5.5 mm)  
Utility knife  
File  
Hacksaw blade  
Felt-tip pen  
Hole saw (20 mm)  
Shop towel  
Isopropyl alcohol  
Pushpin  
Eye protection  
Scissors  
Blanket  
Masking Tape

## Illustration of the Fog Lights Installed on the Vehicle

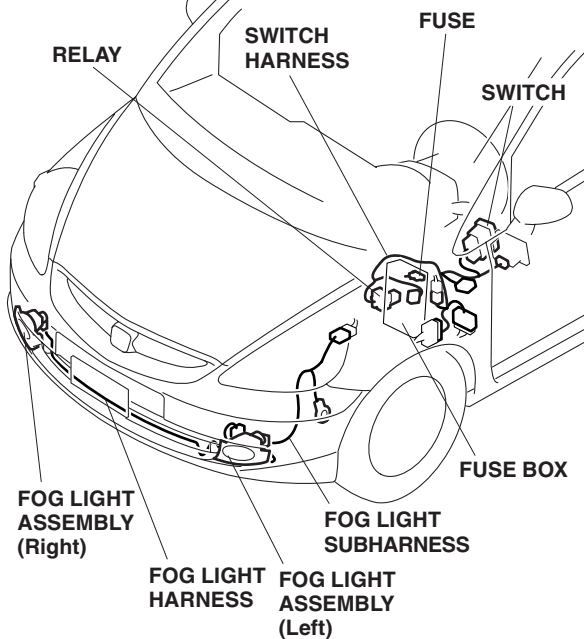

## INSTALLATION

**Customer information:** The information in this installation instruction is intended for use only by skilled technicians who have the proper tools, equipment, and training to correctly and safely add equipment to your vehicle. These procedures should not be attempted by "do-it-yourselfers".

**NOTE:** Be extremely careful not to damage the front bumper or any other finished surfaces of the body.

1. Make sure you have the anti-theft code for the radio, then write down the frequencies for the preset buttons.
2. Disconnect the negative cable from the battery.

### Cutting the Front Bumper

3. Open the hood. Remove the front bumper (eight clips and four self-tapping screws). To prevent damage, set the front bumper on a blanket.

**NOTE:** Have an assistant help you when removing and installing the front bumper.

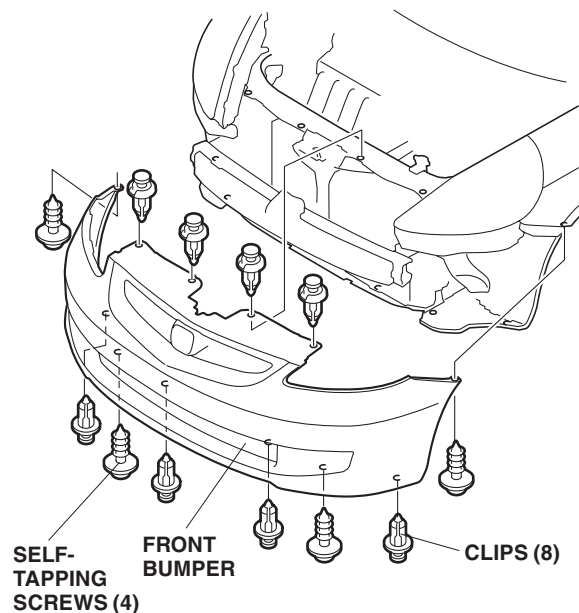

- Remove the left front bumper side vent (three hooks).

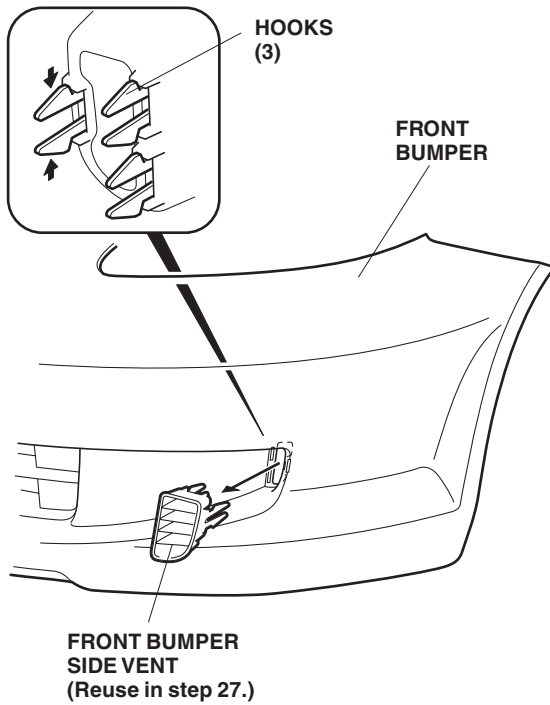

- Using scissors, cut out the template marked "L" along the outer line as shown.

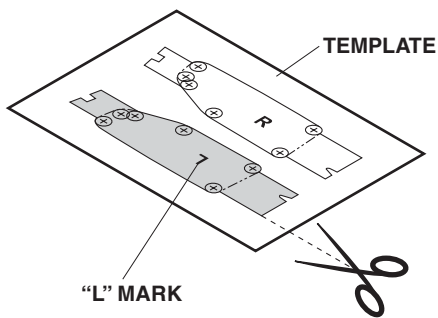

- On the outside of the front bumper, place the left template along the front bumper and tape it in place.

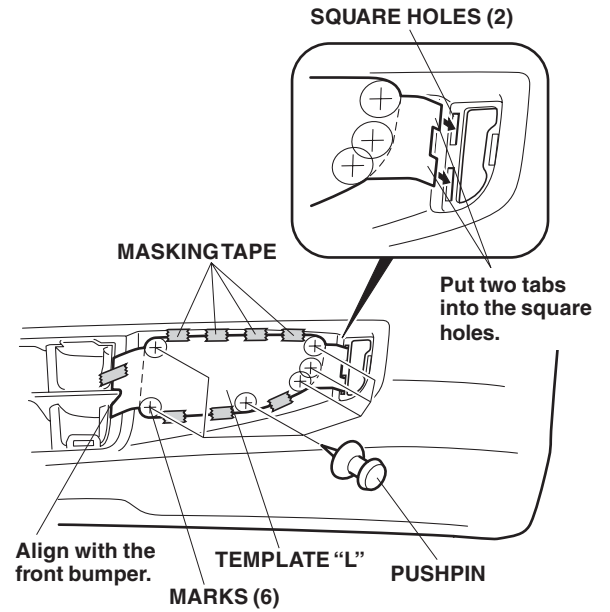

- Using a pushpin, mark the front bumper at each of the six marks printed on the template.
- Using a utility knife, cut the template along the broken lines.

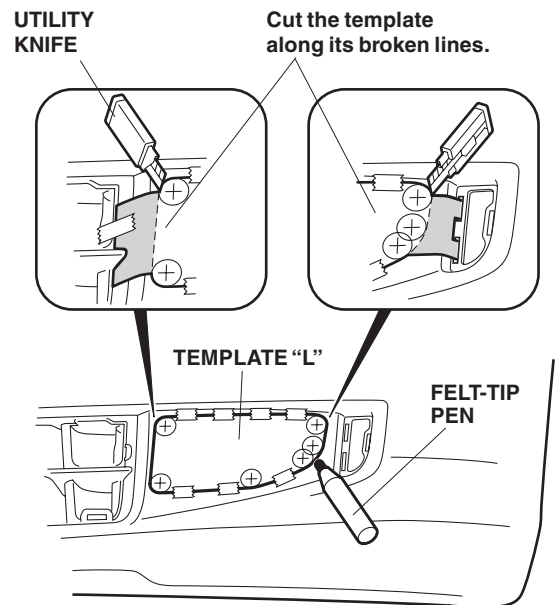

- Using a felt-tip pen, mark the front bumper along the outer edge of the template. Remove the template.

- To protect the front bumper, apply masking tape in the area shown.

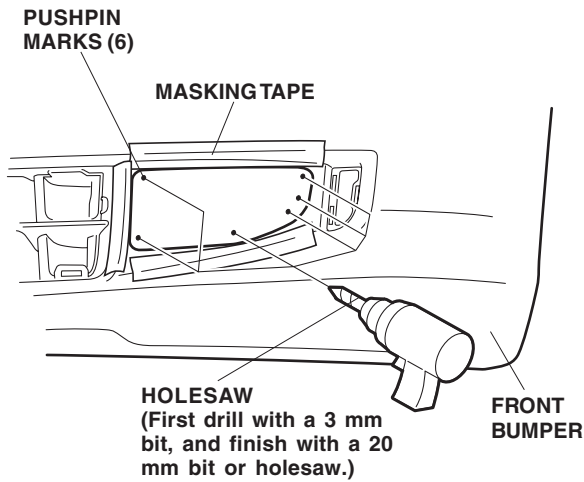

- While wearing eye protection, drill six 20 mm holes through the marks you just made.
- Using a hacksaw blade, cut the bumper along the line made in step 9. Use care when cutting the bumper along the outer line. Remove any burrs from the edge of the hole with a file.

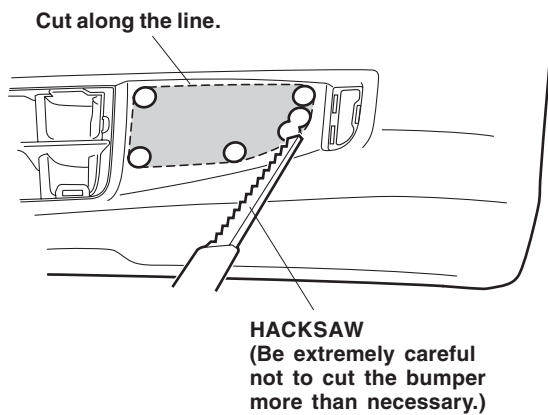

- Locate the dimple on the front bumper. While wearing eye protection, drill a 5.5 mm hole through the dimple. Start with a 3 mm drill bit, and finish with a 5.5 mm drill bit.

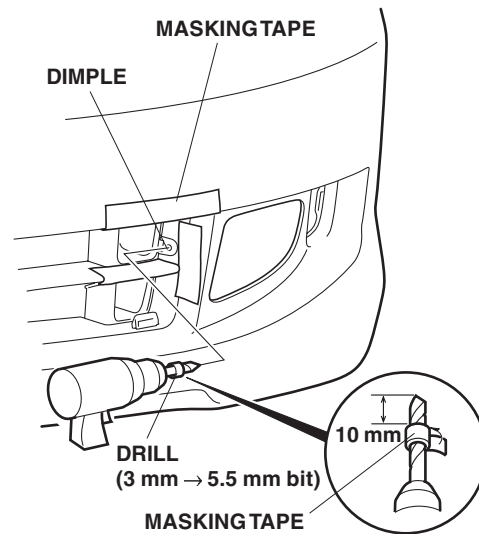

- Repeat steps 4 through 13 to mark and cut the right side of the bumper.

### Routing the Fog Light Subharness

- Remove the left inner fender clip. Pull the left inner fender down; releasing a tab in the direction shown.

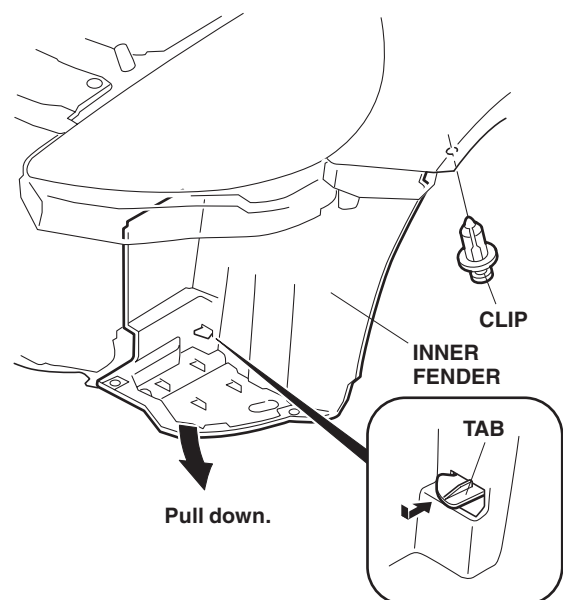

- Inside the left fender area, locate the 1-pin connector blue-taped to the vehicle harness. Remove the blue tape to free the connector.

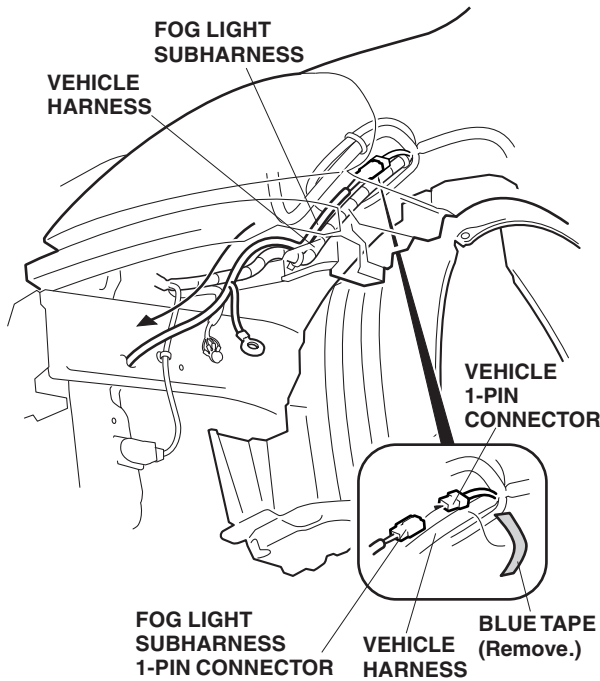

- Plug the fog light subharness 1-pin connector into the 1-pin connector you just freed, then route the fog light subharness along the vehicle harness to the front of the vehicle.
- Locate and remove the ground bolt from the left inner fender area, then secure the fog light subharness ground terminal using the ground bolt.

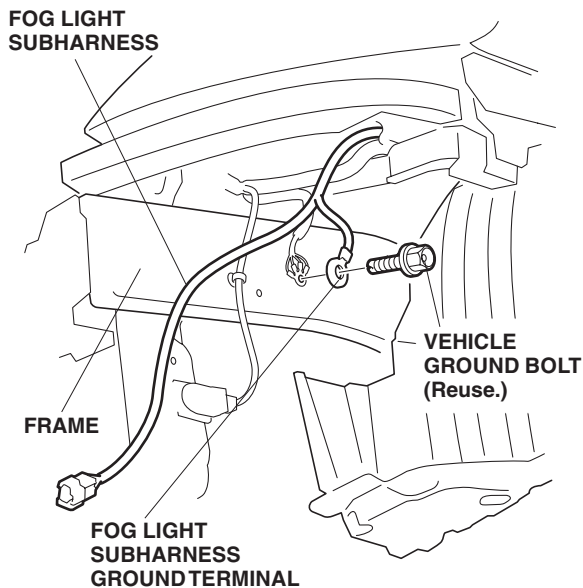

- Secure the fog light subharness to the vehicle frame and panel hole using the two wire ties with clips at the green-taped locations.

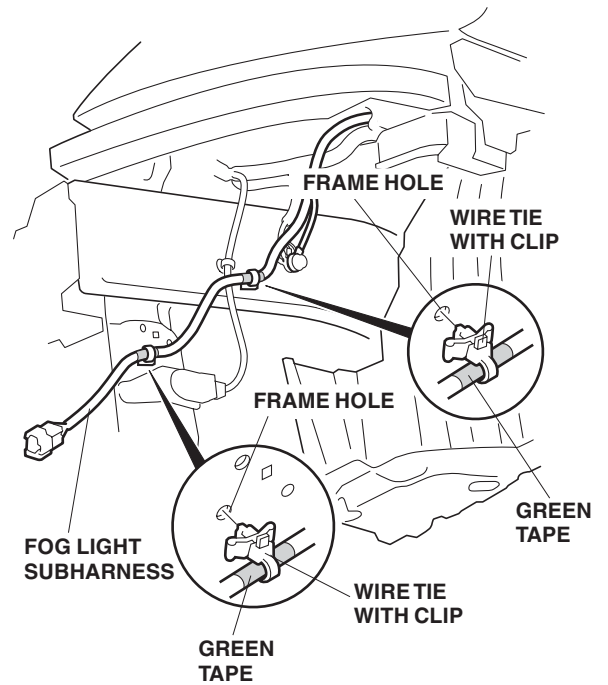

- Secure the fog light subharness to the vehicle harness with three wire ties.

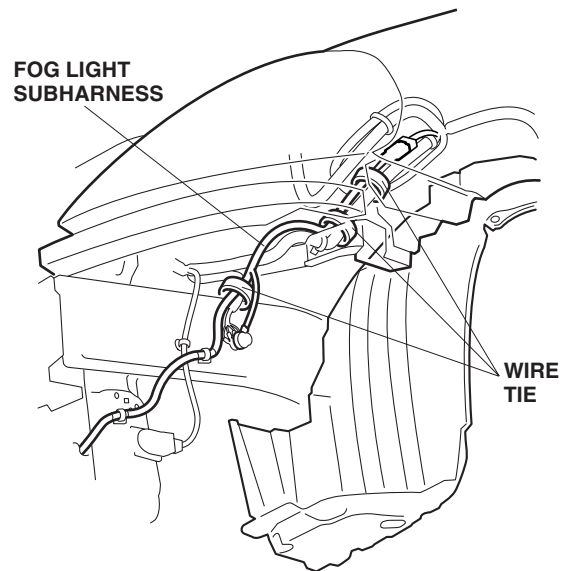

## Routing the Fog Light Harness

21. On the inside of the front bumper on the left side, place the narrowed portion of the fog light harness between the air screen and the front bumper.

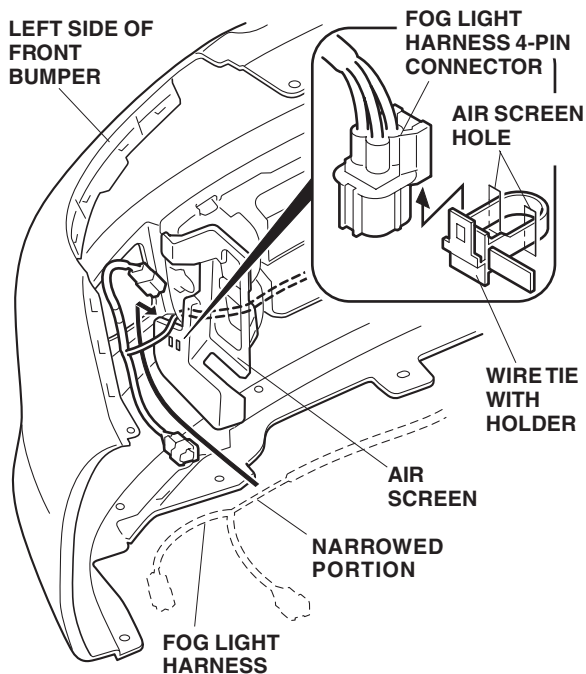

22. Attach the wire tie with holder to the fog light harness 4-pin connector, and route it through the air screen holes.
23. Attach one clip to the fog light harness at the green tape, then attach the clip to the front bumper opening as shown.

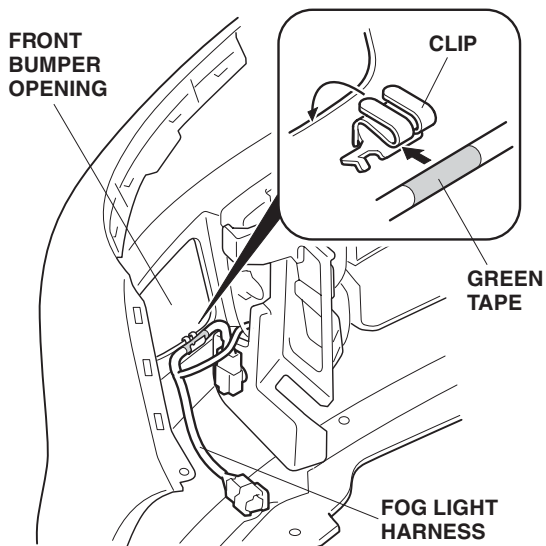

24. Route the fog light harness along the front bumper to the right side of the vehicle and attach the five fog light harness clips to the five ribs inside the front bumper.

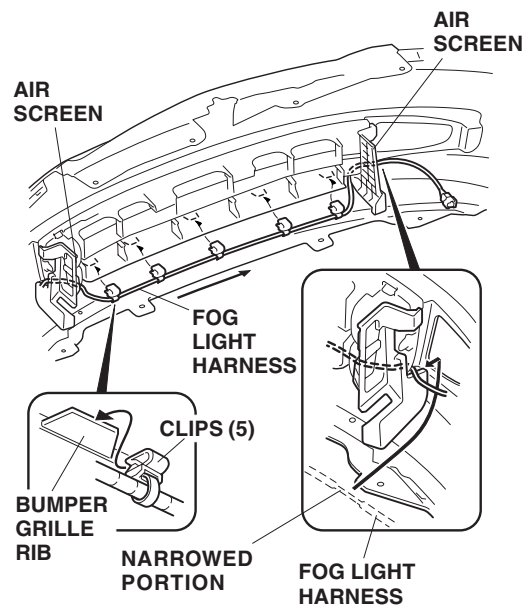

25. Route the narrowed portion of the fog light harness to the right side of the front bumper, the same as in step 21.
26. Attach one clip to the fog light harness at the green tape, then secure the clip to the front bumper opening as shown.

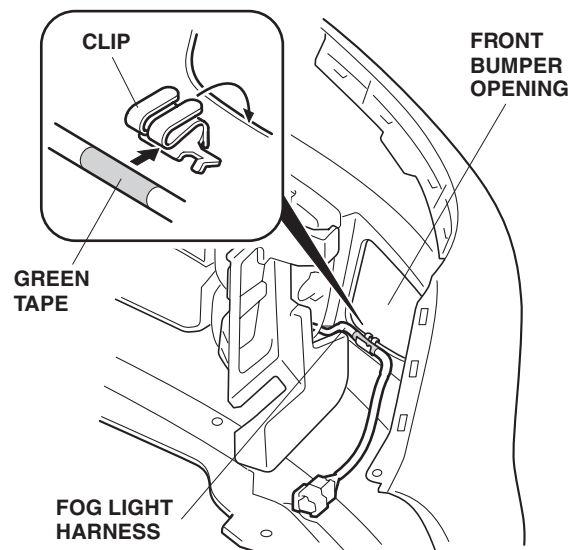

27. Reinstall the front bumper side vents.

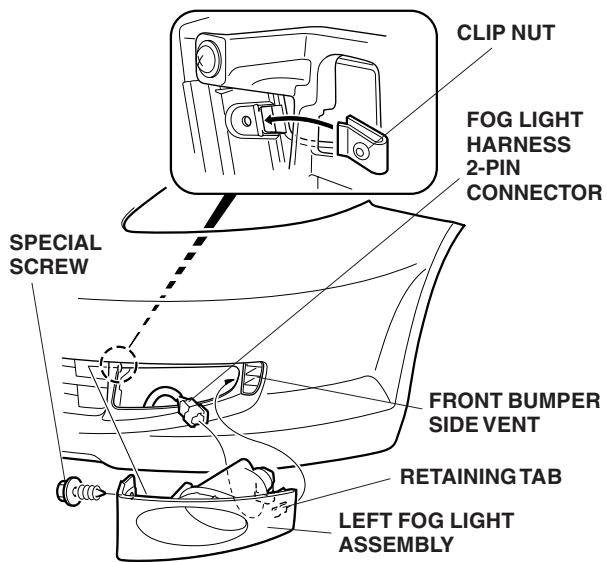

28. Attach one clip nut to the 5.5 mm hole made in step 13. Plug the fog light harness 2-pin connector to the left fog light.
29. Mount the fog light assembly to the front bumper by inserting the retaining tab around the bumper, and installing the self-tapping screw.
30. Install the right fog light assembly the same way.
31. While holding the front bumper near the front of the vehicle, plug the fog light subharness 4-pin connector into the fog light harness 4-pin connector.

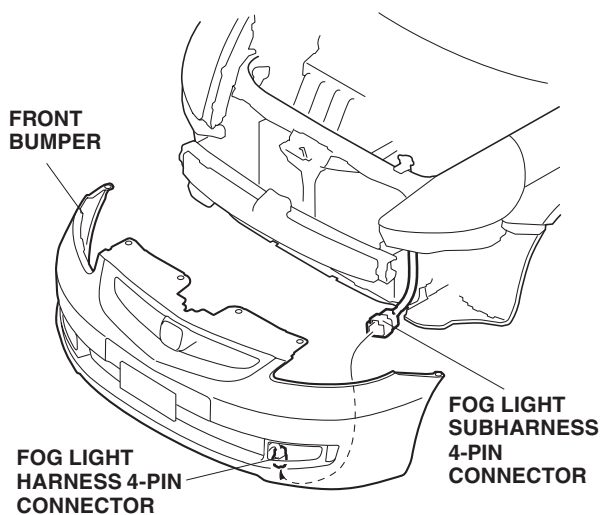

32. Reinstall the front bumper.

### Routing the Switch Harness

33. Remove the driver's dashboard under cover:

- Turn the knob clockwise.
- Release the clip and the pin.

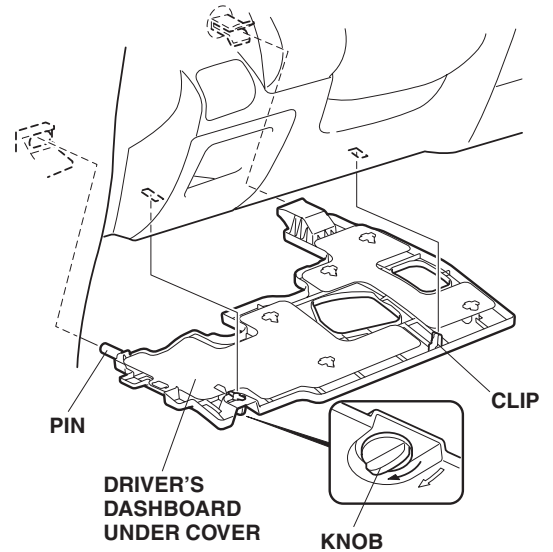

34. Pull away the weatherstrip from around the driver's kick panel. Remove the driver's kick panel (two clips).

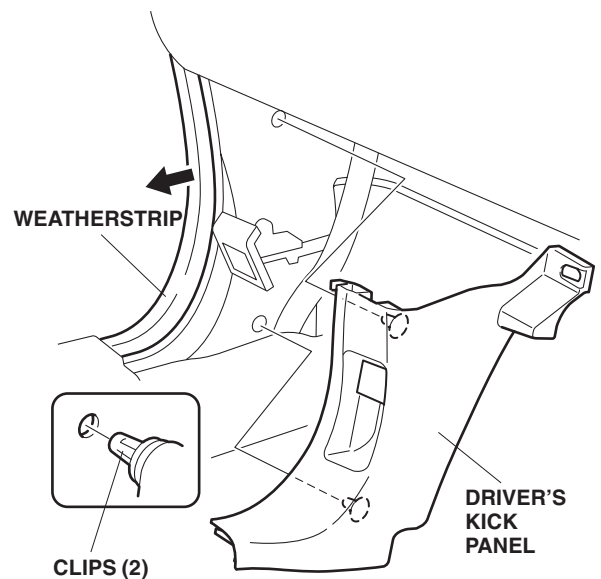



35. Remove the fuse box cover:

- Turn the knob counterclockwise.
- Release the five clips and the three retaining tabs.

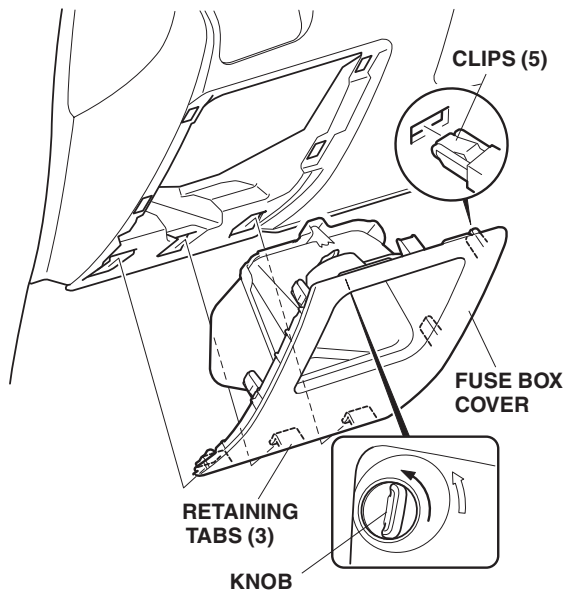

36. Using isopropyl alcohol on a shop towel, thoroughly clean the vehicle fuse label on the back of the fuse box cover.

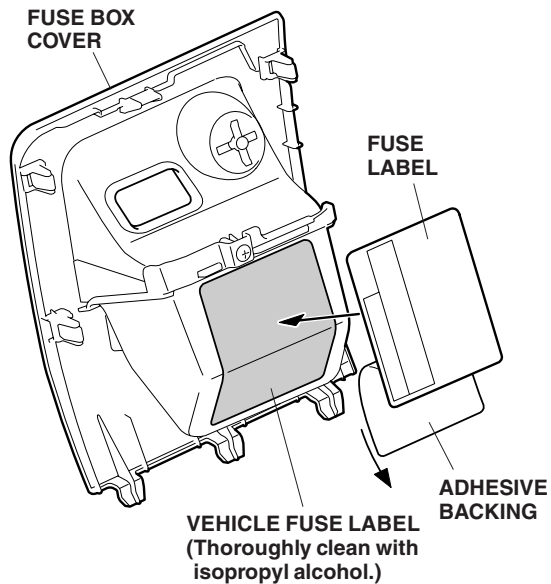

37. Remove the adhesive backing from the fuse label, and then attach the fuse label over the existing vehicle fuse label as shown.

38. Plug the 4-pin relay into the switch harness relay block, then slide the relay block onto the vehicle relay block on the right side of the fuse box.

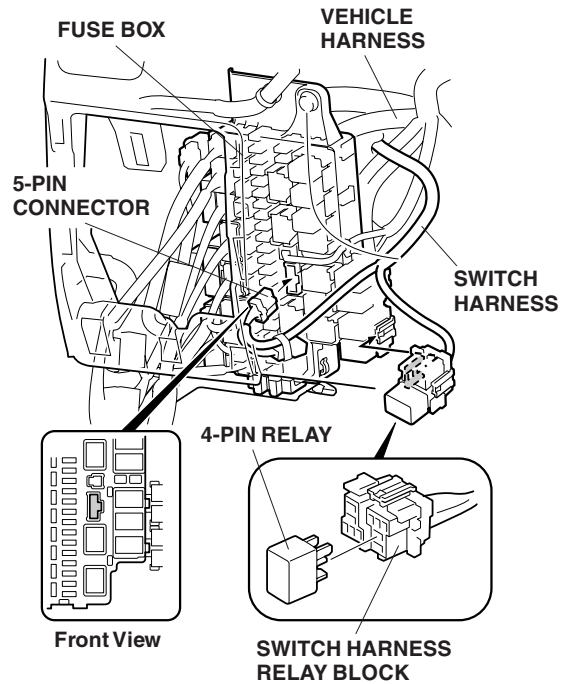

39. Plug the switch harness 5-pin connector into the 5-pin slot of the fuse box.

NOTE: If the fuse box 5-pin connector is already used by another accessory:

Locate the 5-pin connector black-taped to the switch harness, and remove the dummy connector from the 5-pin connector. Plug the other accessory 5-pin connector into the switch harness 5-pin connector (black-taped).

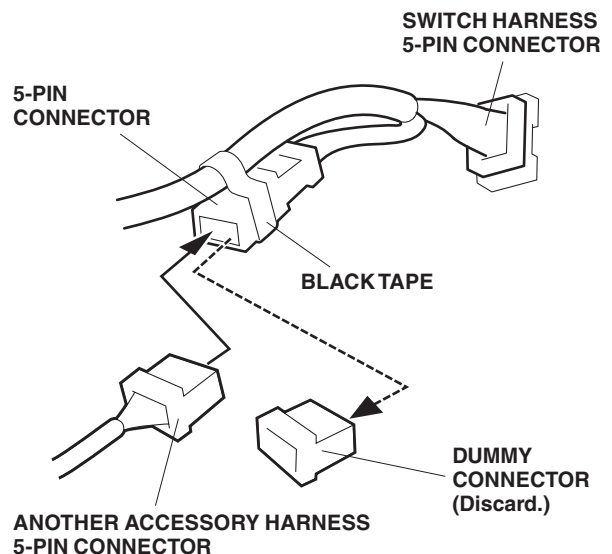



40. Install the 20A fuse into the number 20 slot in the fuse box.

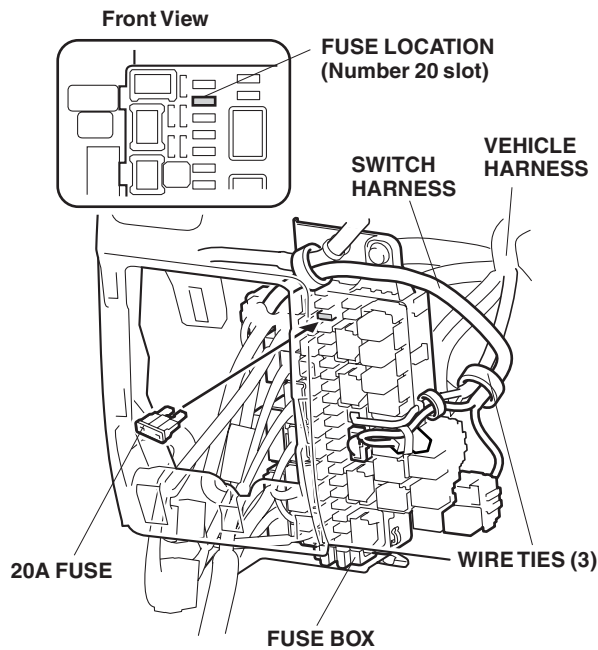

41. Secure the switch harness to the vehicle harness with three wire ties.
42. From behind the dashboard, push out the switch cover from the switch panel, then unplug the 13-pin connector from the mirror switch.

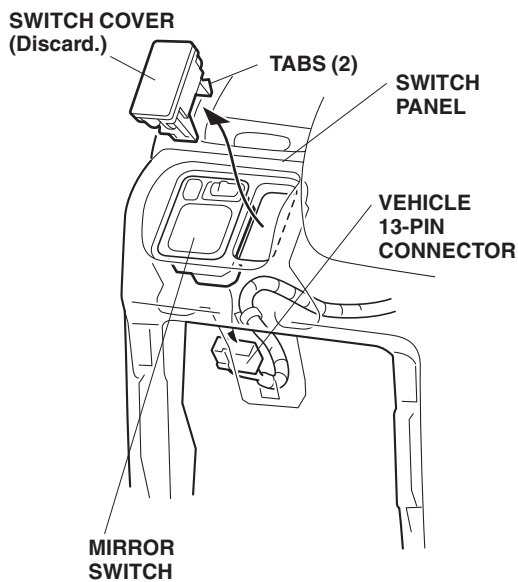

43. Plug the switch harness 13-pin connector into the mirror switch. Plug the vehicle mirror switch 13-pin connector into the switch harness 13-pin connector.

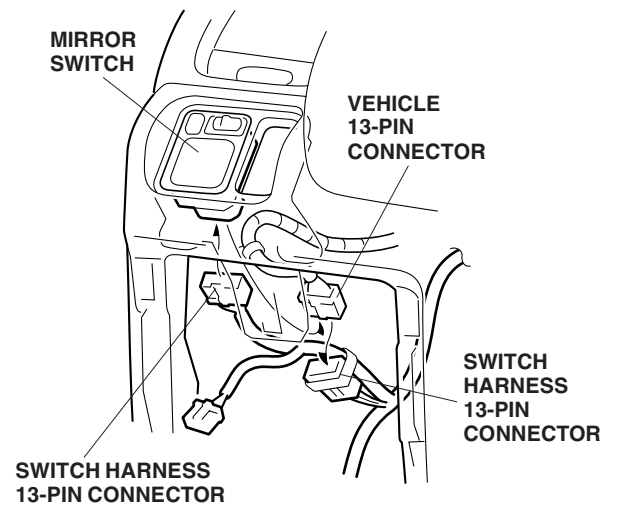

44. Get the fog light switch. Plug the switch harness 5-pin connector into the fog light switch, then install the switch into the dashboard panel.

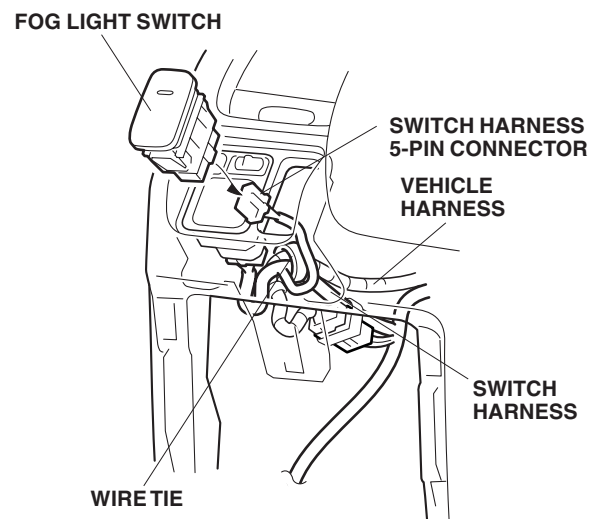

45. Secure the switch harness to the vehicle harness with one wire tie.

- Unplug the vehicle 20-pin connector from the lower left side of the fuse box, and plug the switch harness 20-pin connector into the fuse box.

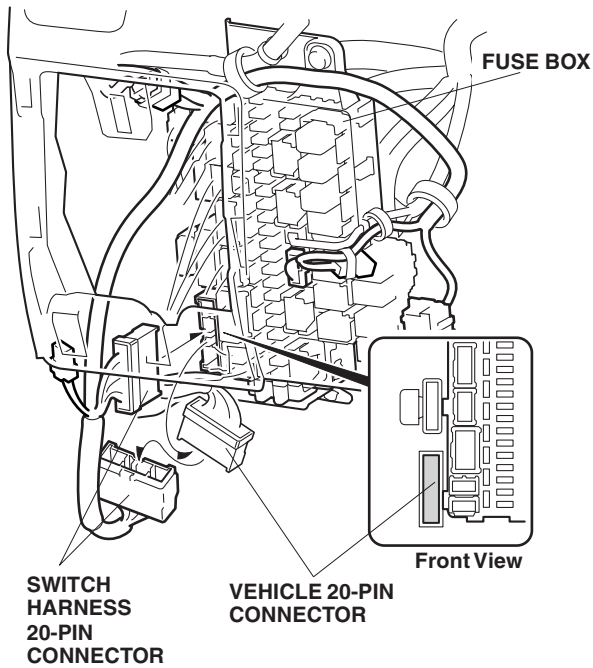

- Plug the vehicle 20-pin connector you just unplugged into the remaining switch harness 20-pin connector.
- Locate the 2-pin connector blue taped to the vehicle harness. Remove the blue tape to free the connector. Plug the switch harness 2-pin connector into the 2-pin connector you just freed.

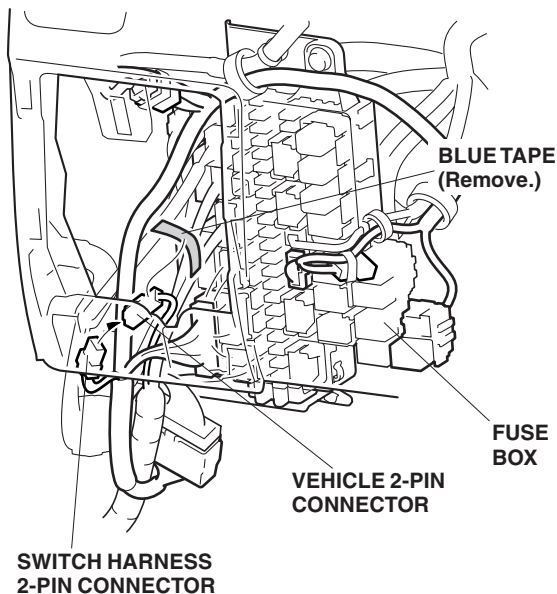

- Secure the 20-pin connector to the vehicle harness using two wire ties connected together.

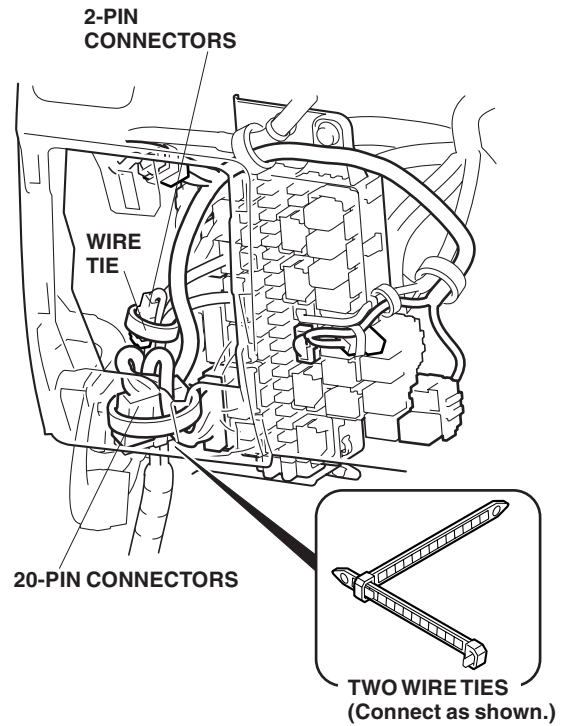

- Secure the 2-pin connector to the vehicle harness with one wire tie.

51. Check that all wire harnesses are routed properly and all connectors are plugged in.
52. Reinstall all removed parts. Check that all clips and fasteners are installed securely.
53. Reconnect the negative cable to the battery.
54. Reset the clock, and reset the radio station presets.

NOTE: When the battery is disconnected, the driver's window AUTO function is disabled.

- Start the engine. Push down on the driver's window switch until the window is fully open.
- Pull up on the driver's window switch to close the window completely, then hold the switch for 2 seconds or more.
- Lower and raise the driver's window to check operation of the driver's window AUTO function.

## USE AND CARE

### How to Operate Fog Lights

NOTE: The fog light lenses can cloud when the outside temperature is cold; this is normal and should go away in warm weather.

- Turn the light switch to the "D" position (headlights on low beam).
- Press the fog light switch (indicator on).
- If the fog lights don't come on, check the fuse and all the connectors, including the ground cable.

### Fog Light Aiming Adjustment

- Adjust the aiming according to local laws and regulations.
- To adjust, turn the aiming adjustment screw in or out until the correct aiming is obtained.

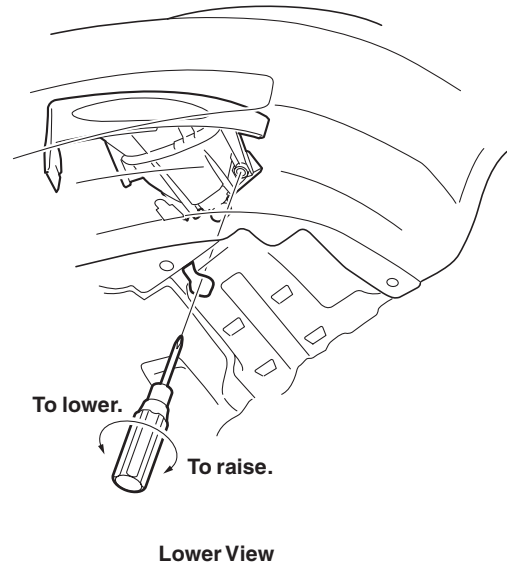

## BULB REPLACEMENT

1. Remove a self-tapping screw and a clip, and then pull back the inner fender.

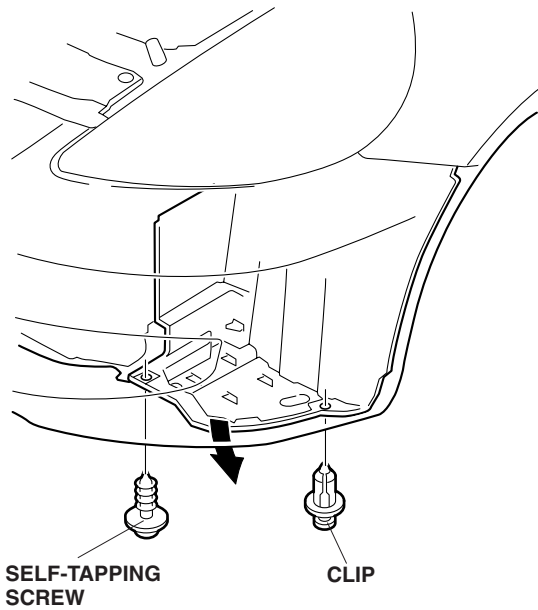

2. Unplug the connector from the fog light.
3. Remove the bulb.

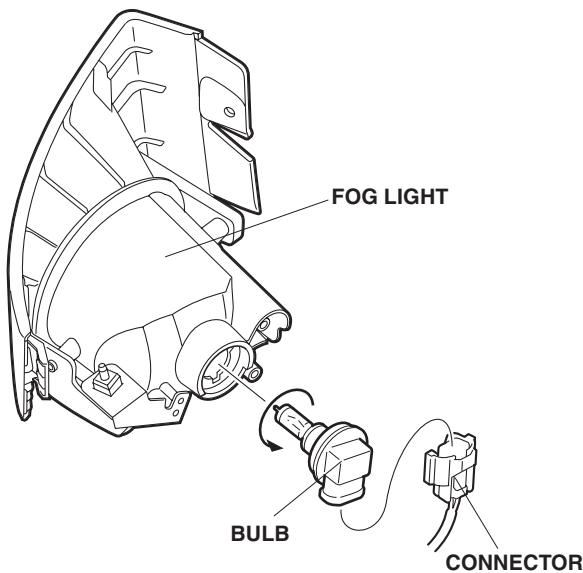

4. Install the new bulb and socket to the fog light.

- Use only a genuine Honda halogen light bulb of specified wattage.

Rating: 12V 55W H11 Halogen Light Bulb P/N 33165-S5A-003

- Do not touch the bulb. Oily or greasy substances on the bulb can shorten its service life due to the heat produced when the bulb is turned on. If the bulb is accidentally touched, wipe it clean with a soft cloth that has been dampened with a denatured alcohol or a mild detergent solution.
- Align the tab on the fog light with the cutout in the bulb when installing the new bulb. If not aligned, the fog light may annoy oncoming drivers.

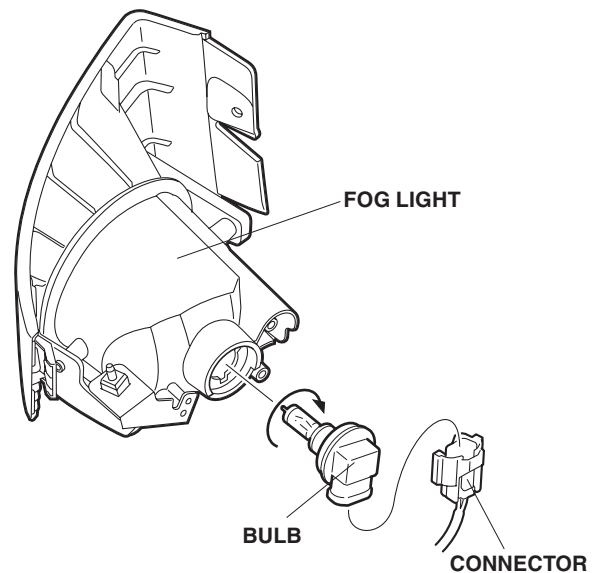

5. Reinstall the removed parts in the reverse order of removal.
  - Check that the wire harnesses are not pinched.
  - Be sure to tighten the self-tapping screw and bolts securely.
6. Check the operation of the fog light; adjust the aiming if necessary.

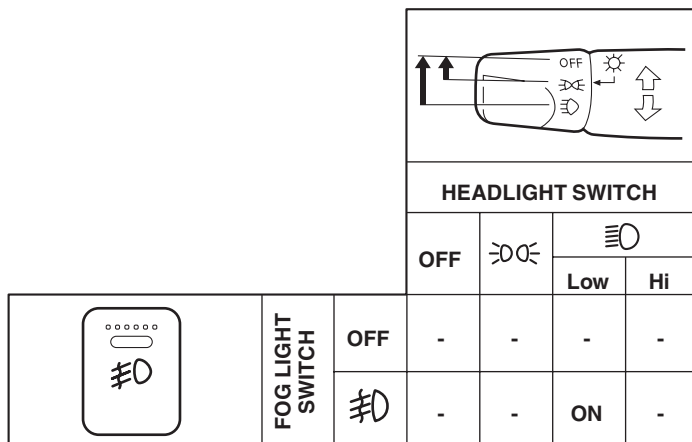
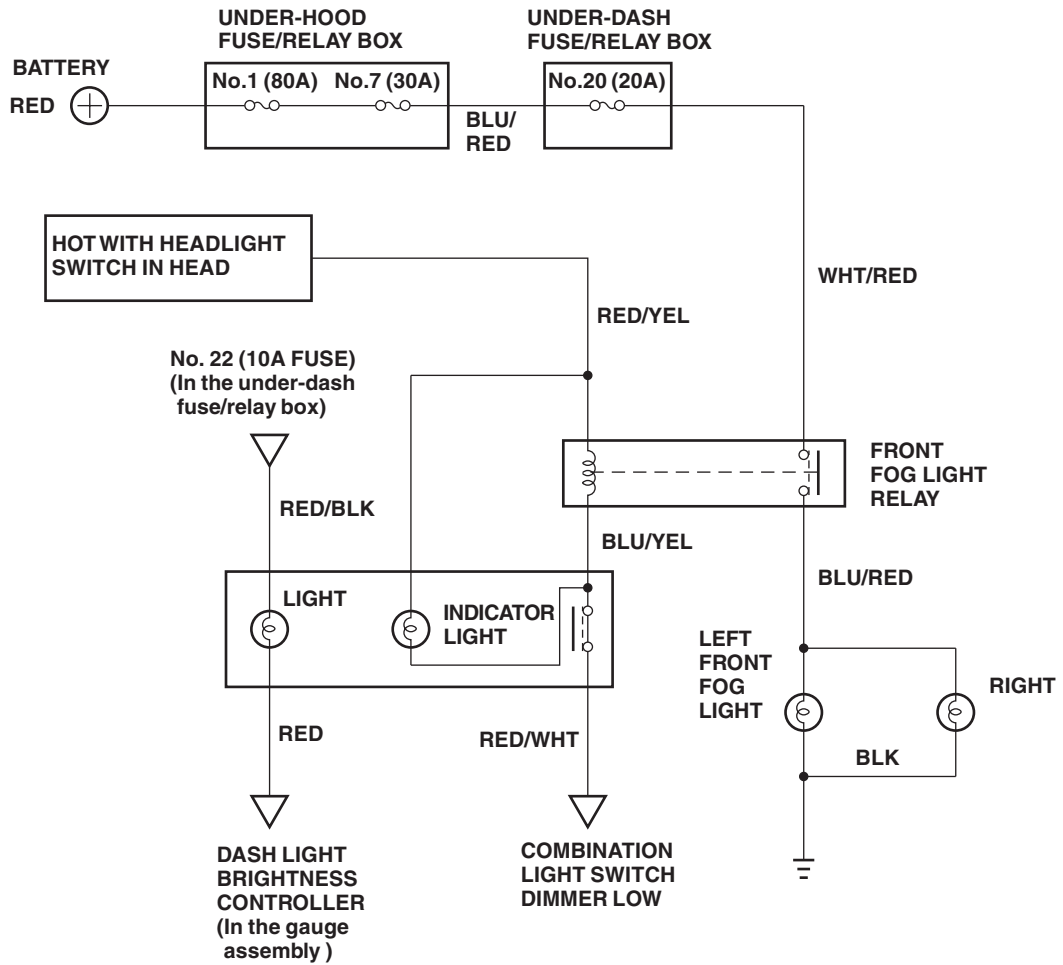

BLK	BLACK	BRN	BROWN
YEL	YELLOW	ORN	ORANGE
BLU	BLUE	PUR	PURPLE
GRN	GREEN	NAT	NATURAL
RED	RED	PNK	PINK
WHT	WHITE	GRY	GRAY
LT BLU	LIGHT BLUE	LT GRN	LIGHT GREEN