



INSTALLATION INSTRUCTIONS

Accessory

SIDE UNDER SPOILER

Application

2007 CIVIC SI

Publications No.

All 33461

Issue Date

AUG 2006

PARTS LIST

Left side under spoiler

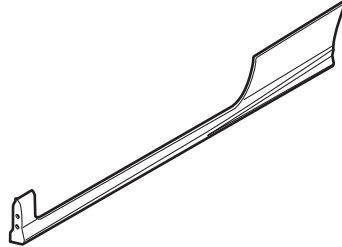

Right side under spoiler

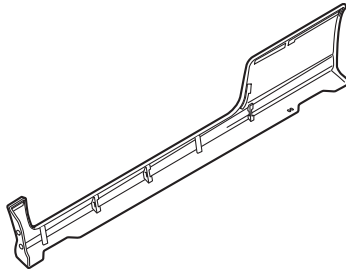

2 Side lower brackets

The side lower bracket will deform easily. Handle the part carefully with both hands when you move it.

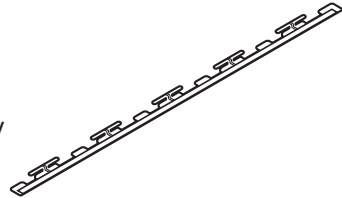

Template

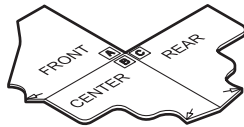

4 Self-tapping screws



2 Under brackets

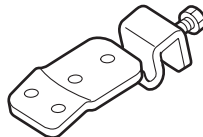

4 Screws



PARTS LIST

Left side sticker
(Sold separately)

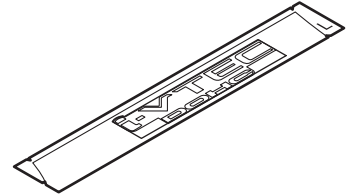

Right side sticker
(Sold separately)

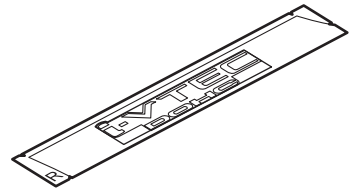

TOOLS AND SUPPLIES REQUIRED

Phillips screwdriver

Tape measure

Felt-tip pen

Shop towel

Isopropyl alcohol

Masking tape

Scissors

Utility knife

Touch-up paint

8 mm Wrench

Gloves

Heat gun

Sprayer

Squeegee

Neutral detergent

INSTALLATION

NOTE:

- Be careful not to damage the body finish when installing the side under spoilers.
- Install the left side under spoiler first, then install the right side under spoiler.
- Be sure to use the bolts, nuts, and screws furnished with this kit. Use of bolts, nuts and screws other than those not included in this kit can cause damage to the parts.
- These installation instructions show the left side under spoiler being installed. The same procedure applies to installing the right side under spoiler.
- Wear gloves to protect your hands while handling the side lower bracket.
- This side under spoiler kit should be installed only if the ambient air temperature is 60°F (15°C) or above.
- To allow the adhesive to cure, do not wash the vehicle for 24 hours.

1. Position the left side under spoiler on the vehicle body to check the installation position. Using isopropyl alcohol on a shop towel, clean the surface of the vehicle thoroughly where the left side under spoiler will be attached to ensure secure adhesion of the double-sided adhesive tape.

Thoroughly clean the surface where the left side under spoiler will be attached with isopropyl alcohol.

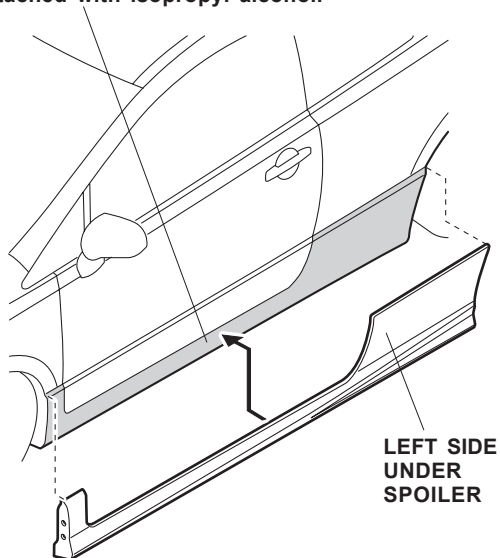

2. Using a tape measure and felt-tip pen, measure and mark the body as shown.

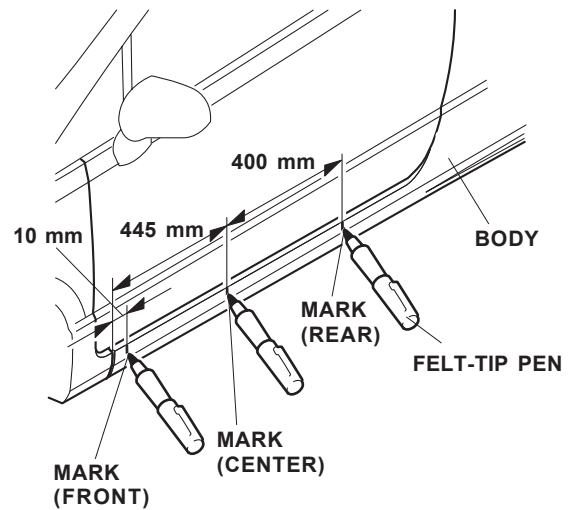

3. Cut out part A from the template.

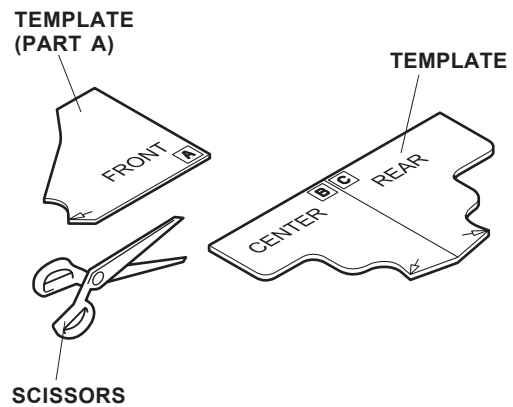

4. Measure and cut both ends of the adhesive backing attached to the inner side of the side lower bracket, and remove the cut pieces of the adhesive backing from both ends.

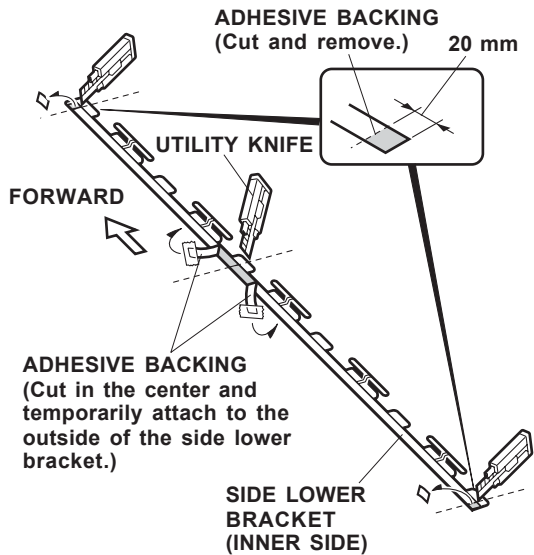

5. Using a utility knife, cut the center of the adhesive backing attached to the side lower bracket.
6. Attach a piece of adhesive tape to each of the cut ends of the adhesive backing, and then temporarily attach them to the outside of the side lower bracket.

7. Align the first rib on the front of the side lower bracket with the mark (front) you made in step 2.

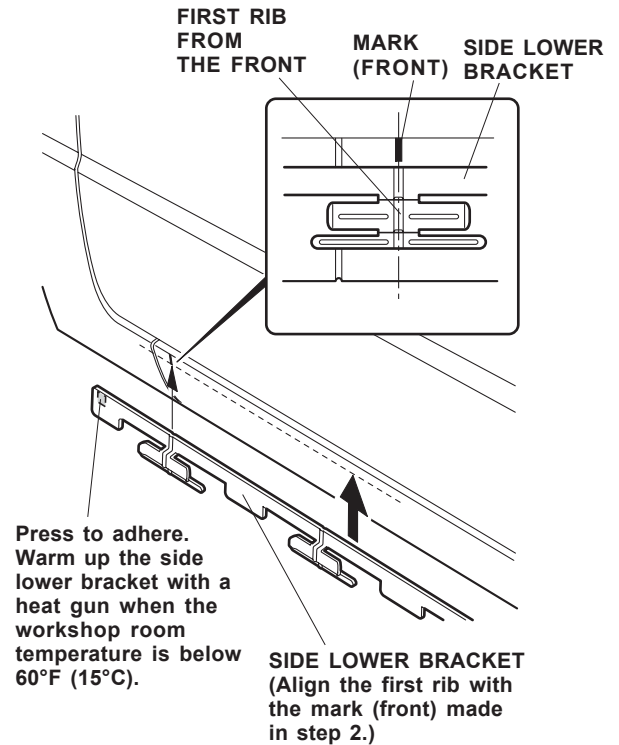

8. Temporarily adhere the side lower bracket to the vehicle body by pressing the front end of the side lower bracket (where you removed the adhesive backing) against the vehicle body.
 - Carefully position the side lower bracket on the vehicle body so you don't bend it, and adhere it to the vehicle body securely.
 - Wear gloves to protect your hands during this operation.
 - Do not worry if the side lower bracket is slightly slanted as vertical adjustment of the side lower bracket is not made in this step of the procedure.
 - If the side lower bracket comes off after temporarily adhering it, repeat step 1 to clean the surface with isopropyl alcohol where the side lower bracket will attach.
 - When the workshop room temperature is below 60°F (15°C), warm up the side lower bracket to 60°F (15°C) or above before attaching it to the vehicle body.

9. Open the left door. Position the rear (C) template on the mark (rear) you made in step 2. Position the top of the side lower bracket so that it lightly contacts the rear(C) template.

- Push the template against the vehicle body so there is no gap between the template and the body.

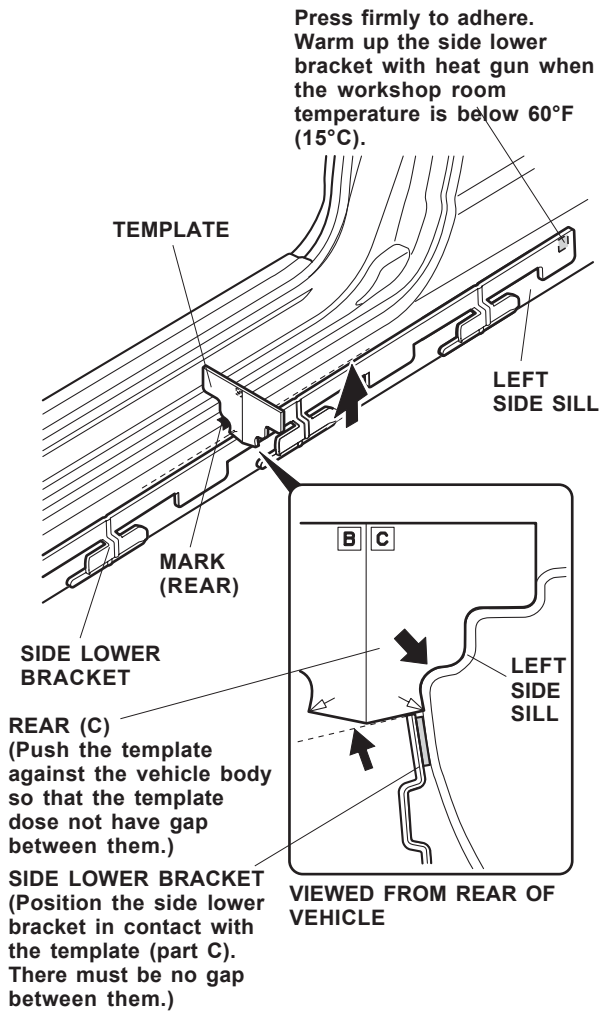

10. Press the rear end of the side lower bracket (where you removed the adhesive backing) to adhere the part firmly to the vehicle body.

- Carefully position the side lower bracket on the vehicle body so you do not bend it, and adhere it to the vehicle body securely.
- Wear gloves to protect your hands during this operation.
- When the workshop room temperature is below 60°F (15°C), warm up the side lower bracket to 60°F (15°C) or above before attaching it to the vehicle body.

11. Close the left door. Detach the front end of the side lower bracket from the vehicle body. Position the front (A) template on the mark (front) you made in step 2. Align the top of the first rib from the front end of the side lower bracket with the front (A) template.

- Push the template against the vehicle body so there is no gap between the template and the body.

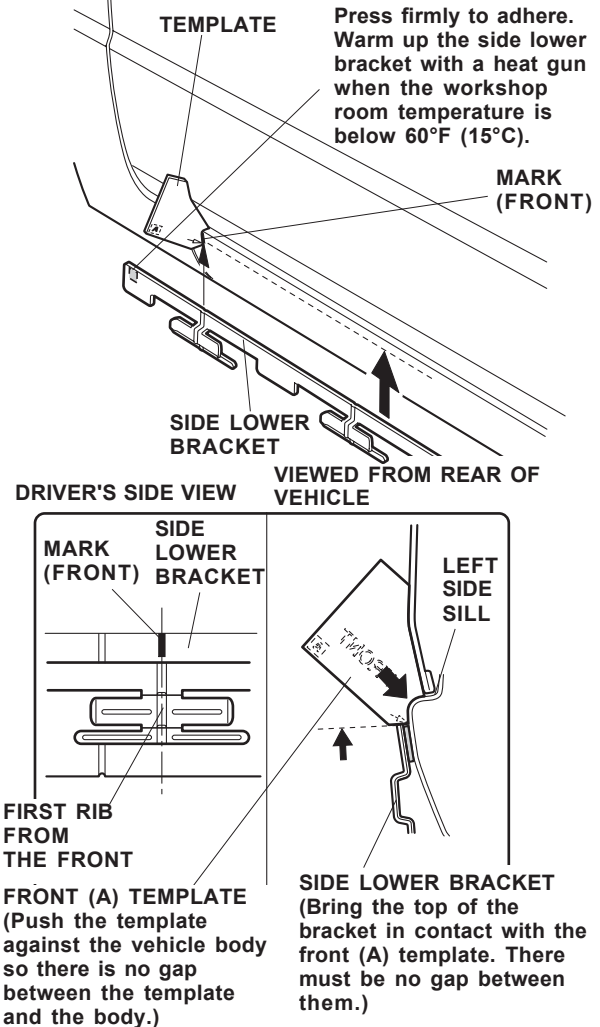

12. Press the front end of the side lower bracket (where you removed the adhesive backing) to adhere the part firmly to the vehicle body.

- Carefully position the side lower bracket on the vehicle body so you do not bend it, and adhere it to the vehicle body securely.
- Wear gloves to protect your hands during this operation.
- When the workshop room temperature is below 60°F (15°C), warm up the side lower bracket to 60°F (15°C) or above before attaching it to the vehicle body.

- Open the left door. Position the center (B) template on the mark (center) you made in step 2. While holding the ends of the side lower bracket that you already adhered, position the top of the center of the side lower bracket with the center (B) template.

- Push the template against the vehicle body so there is no gap between the template and the body.

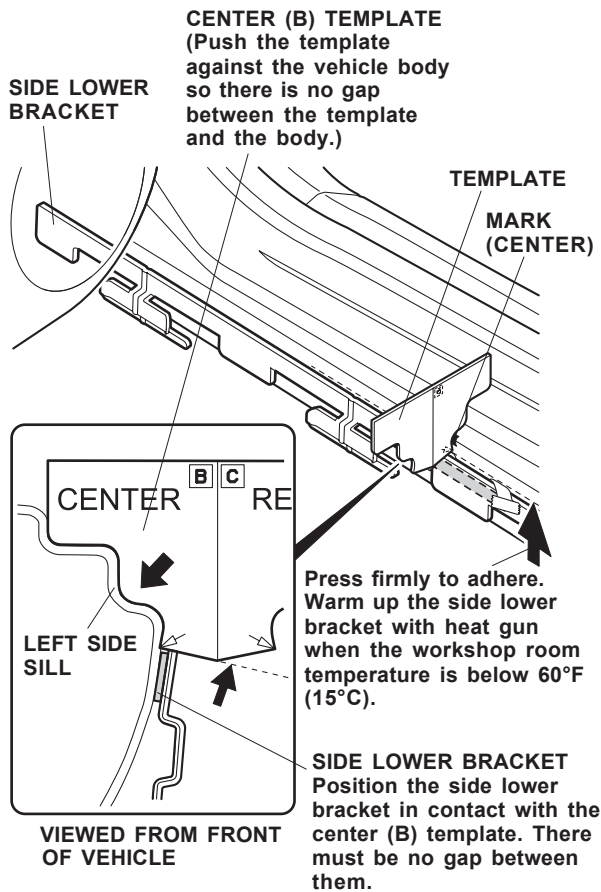

- Press the side lower bracket in the center (where the adhesive tape was peeled back) to adhere it firmly.
 - Carefully position the side lower bracket on the vehicle body so you do not bend it, and adhere it to the vehicle body securely.
 - Wear gloves to protect your hands during this operation.
 - When the workshop room temperature is below 60°F (15°C), warm up the side lower bracket to 60°F (15°C) or above before attaching it to the vehicle body.

- Close the left door.

- Press the side lower bracket lightly from the center to the ends while removing the adhesive backing.

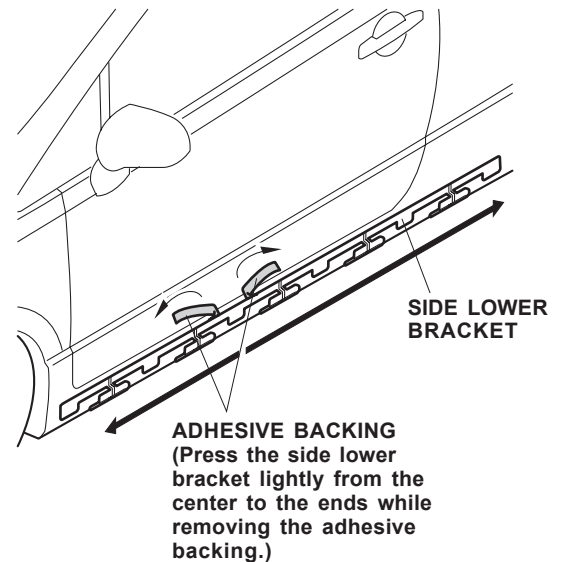

- When the workshop room temperature is below 60°F (15°C), warm up the entire side lower bracket to 60°F (15°C) or above before attaching it to the vehicle body.

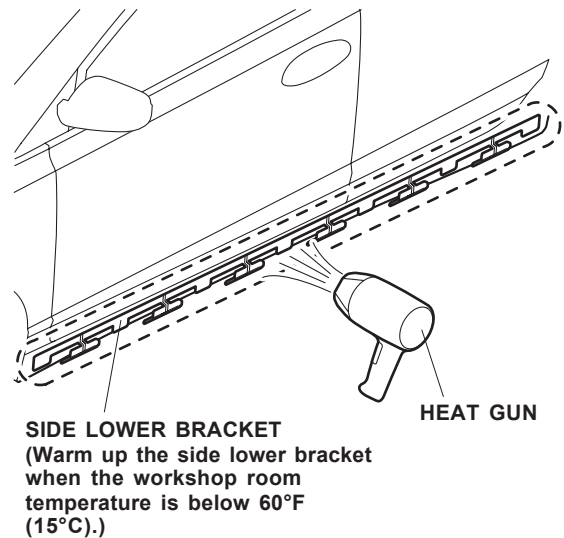

17. Adhere the side lower bracket to the vehicle body by pressing firmly along the double-sided adhesive tape with the palms of your hands.

- Do not push the side lower bracket installation plates; it deforms the installation plates and prevents you from installing the side under spoiler.
- When the workshop room temperature is below 60°F (15°C), warm up the entire side lower bracket to 60°F (15°C) or above before attaching it to the vehicle body.
- Wear gloves to protect your hands during this operation.

SIDE LOWER BRACKET
(Press the entire surface of the double-sided adhesive tape.)

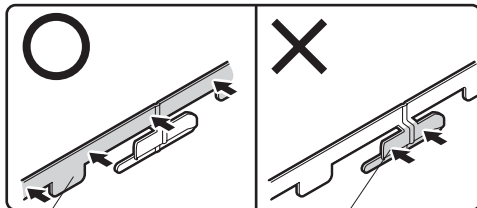
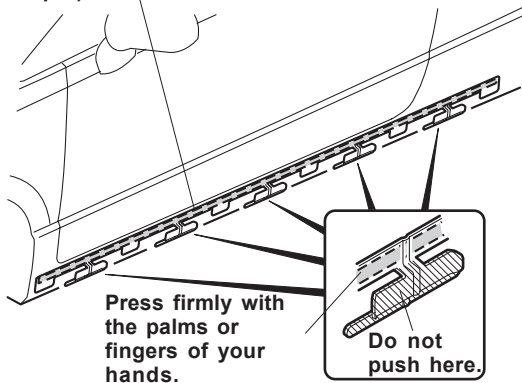

Press firmly with the palms or fingers of your hands.

Do not push here.

19. Turn the steering wheel all the way counterclockwise.

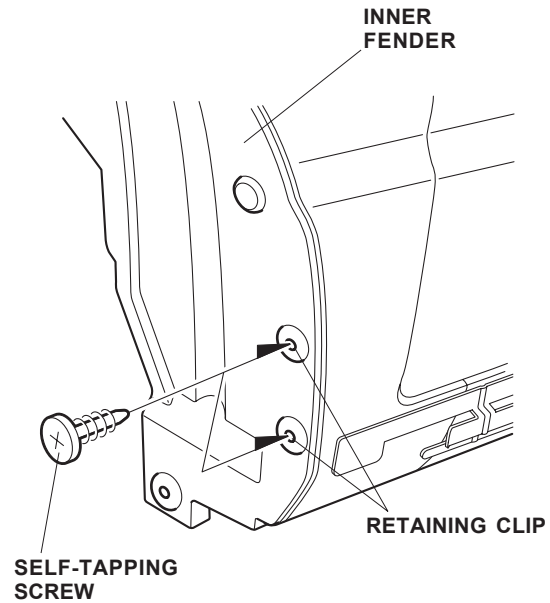

20. Using a self-tapping screw, pierce a hole through the center of the inner fender retaining clips.

21. Attach a piece of adhesive tape to the end of each adhesive backing on the inner side of the left side under spoiler. Peel back the adhesive backings a little and temporarily attach them to the outside surface of the left side under spoiler.

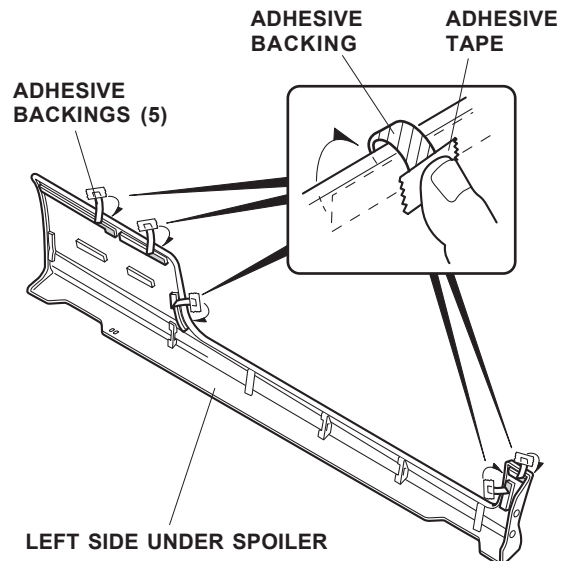

22. Check the position of the under spoiler attachments by looking down at them from the top. While pushing the under spoiler against the vehicle body with both hands, slide the left side under spoiler rearward.
- Make sure the location of the side lower bracket installation plates (upper and lower) attach to the brackets on the left side under spoiler.

SIDE LOWER BRACKET INSTALLATION PLATE (UPPER) **LEFT SIDE UNDER SPOILER**
(Slide the left side under spoiler rearward while pushing it against the vehicle body.)

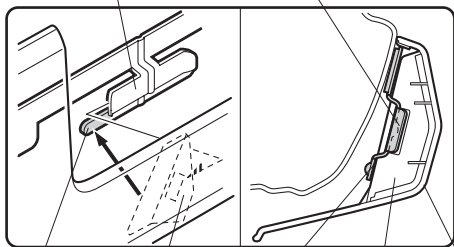
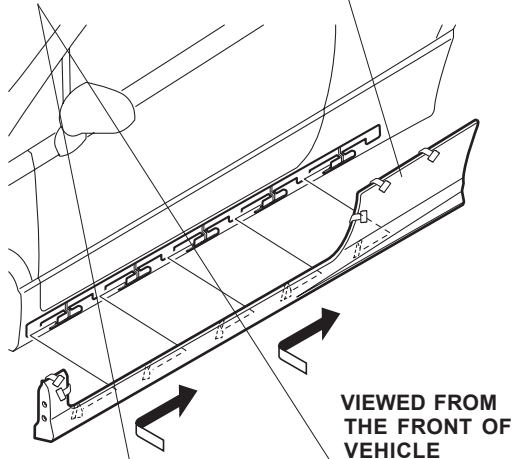

SIDE LOWER BRACKET INSTALLATION PLATE (LOWER) **SIDE LOWER BRACKET INSTALLATION PLATE (LOWER)** **LEFT SIDE UNDER SPOILER**

BRACKET ON LEFT SIDE UNDER SPOILER **BRACKET ON LEFT SIDE UNDER SPOILER**

23. Check that all six brackets on the left side under spoiler are set in the side lower bracket installation plates.
- Visually check that there is no excessive gap between the left under spoiler and the vehicle. If an excessive gap is found, repeat step 22.

24. Fit the under bracket to the side under spoiler and mark the undercoat.

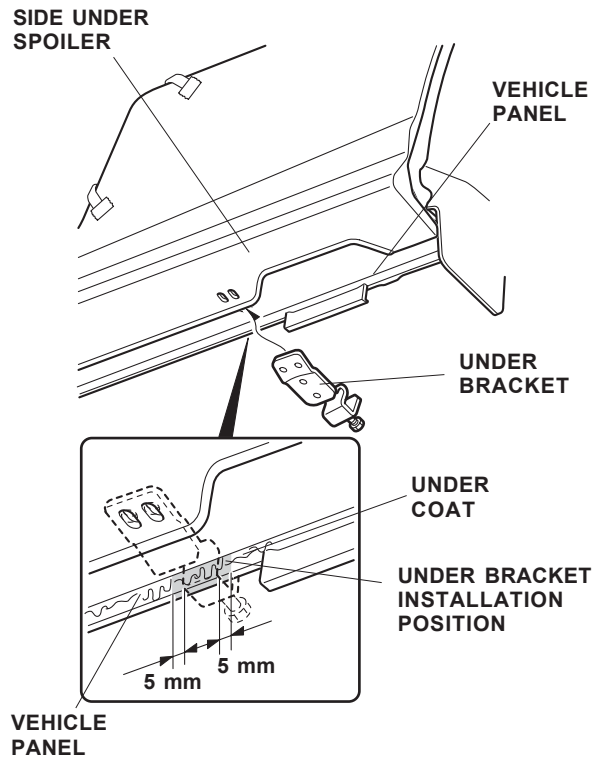

25. Cut into the marked area of the undercoat with a utility knife, and file off the undercoat from both sides of the vehicle panel.

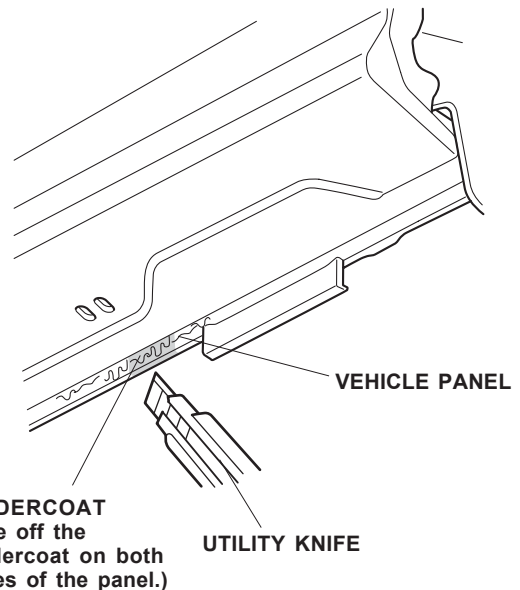

26. Apply touch-up paint to the vehicle panel in the area where you filed off the undercoat.
- Do not install the under bracket until the touch-up paint dries.

27. Gently tap on the left side under spoiler to remove any gap between the spoiler and the wheel arch.

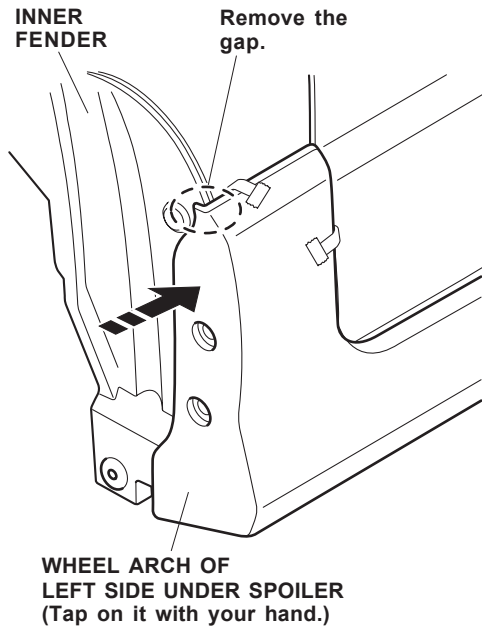

28. Loosely install the front self-tapping screws in the holes on the wheel arch of the left side under spoiler.

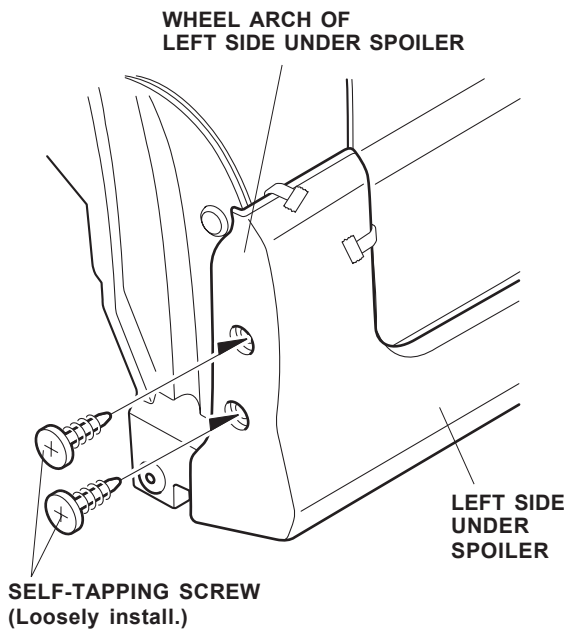

29. When the touch-up paint has dried, loosen the under bracket bolt completely until the washer on the bolt comes in contact with the under bracket. Take care not to allow the washer to come off. Do not loosen the under bracket bolt with a wrench; it can damage the washer on the bolt. Loosen the under bolt with your hand.

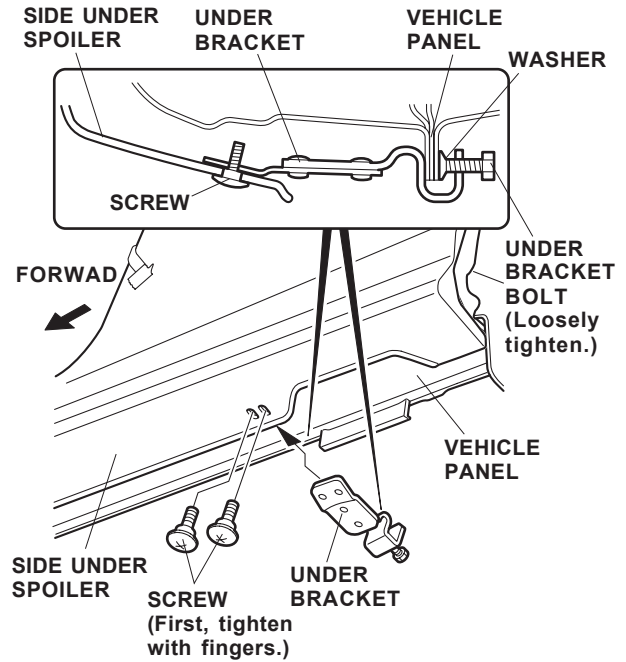

30. Position the under bracket on the side under spoiler, and loosely install the two screws. Tighten the under bracket bolt, but don't tighten it completely yet.

- Align the rear top edge of the left side under spoiler with the edge of the radius of the vehicle panel as shown. Remove the five adhesive tapes from the left side under spoiler. Press firmly on the side under spoiler firmly.

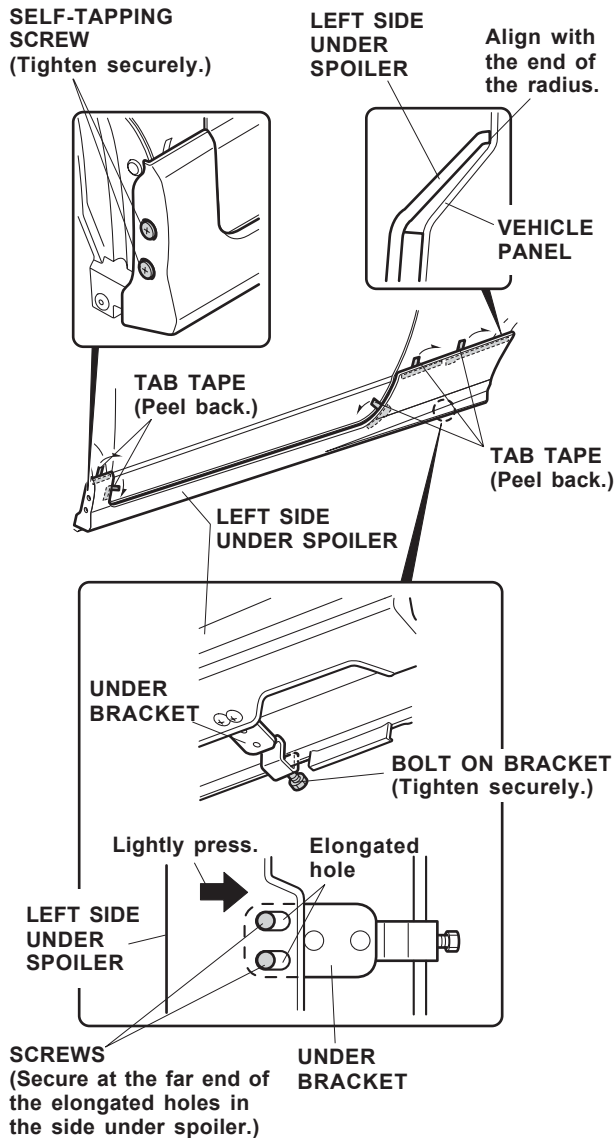

- Tighten the two self-tapping screws securely.
- Lightly press the side under spoiler against the vehicle and tighten it with two screws in the under bracket.
- Tighten the bolt on the under bracket securely.
- Repeat for the right side under spoiler.

- Using a tape measure, mark on the left side under spoiler at the positions shown with a felt-tip pen.

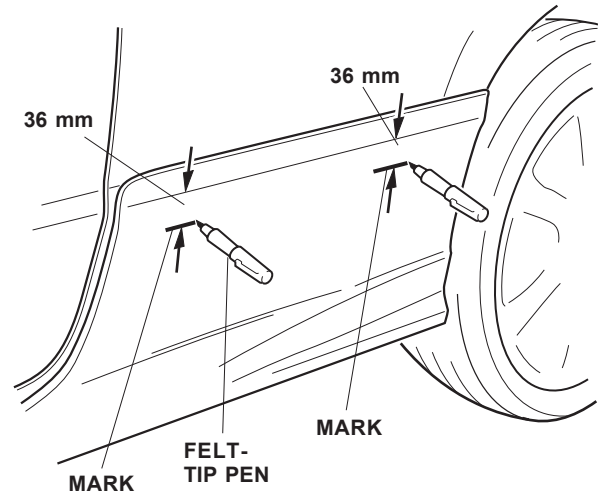

- Using isopropyl alcohol on a shop towel, attach the sticker to the side under spoiler at the marks you made in step 36. Align the corner of the sticker to the rear edge of the side under spoiler.

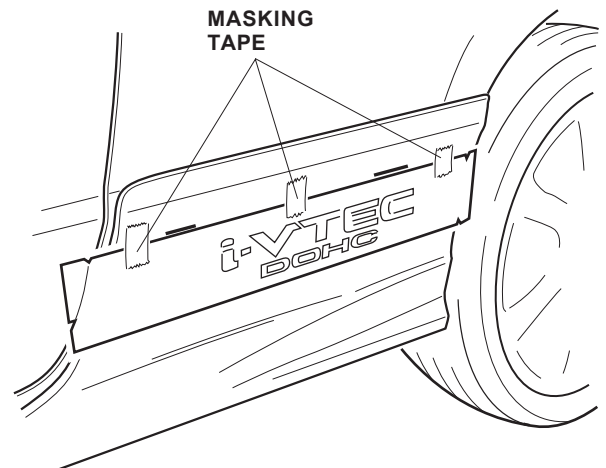

Align the corner of the sticker to the rear edge of the side under spoiler.

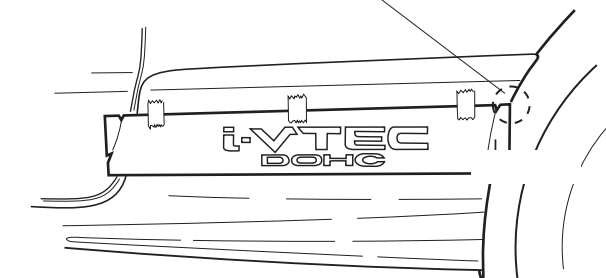

38. Peel back the end of the backing, and spray a natural detergent solution onto the adhesive side.

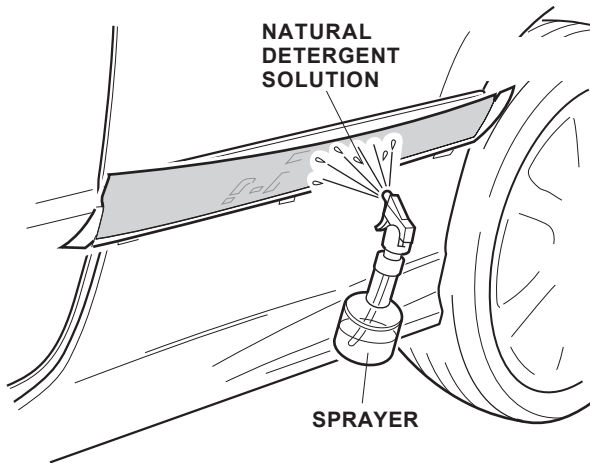
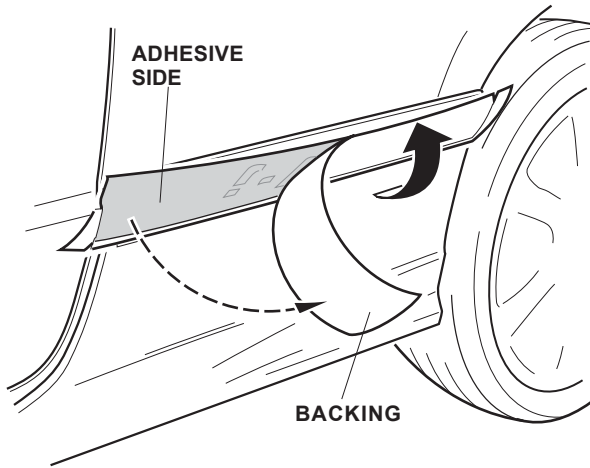

39. While holding the sticker to keep it from moving, work out any air bubbles with a squeegee.

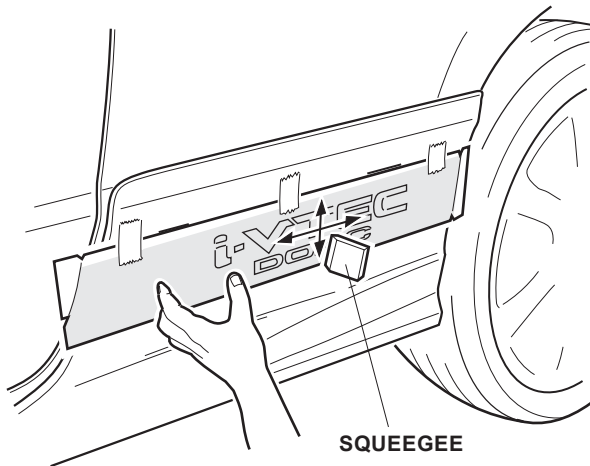

40. Gently peel off the protective film at an angle.

