



INSTALLATION INSTRUCTIONS

Accessory
**CD CHANGER ATTACHMENT
 (Trunk Mount)**

Application
**2007 CIVIC
 4-DOOR Si**

Publications No.
All 33881

Issue Date
OCT 2006

PARTS LIST

**CD Changer Attachment (Sold Separately)
 P/N 08B26-SNA-100**

CD changer bracket

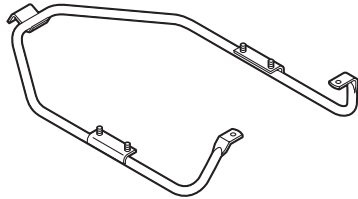

2 Side brackets

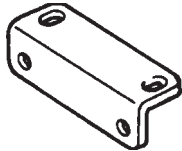

3 Clip nuts



3 EPT seals

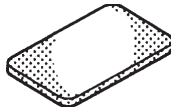

3 Washer-bolts



4 Flange nuts



15 Wire ties

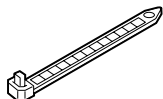

2 Wire ties with clip

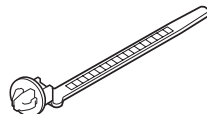

8 Cushion tapes

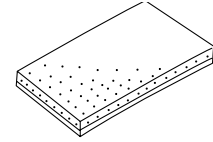

BUS cable

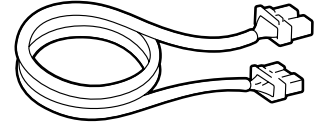

4 Washer screws



**CD Changer Kit (Sold Separately)
 P/N 08A26-5E1-100**

CD changer

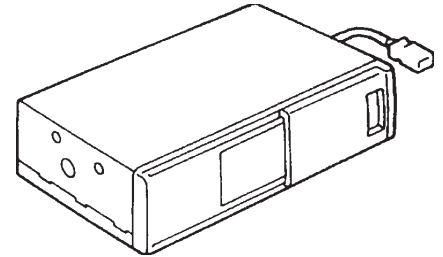

Bracket

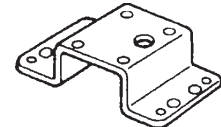

8-Disc CD magazine

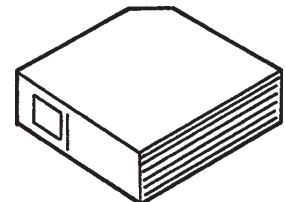

8 Washer-screws, 4 x 6 mm



Accessory owner's information manual



TOOLS REQUIRED

Phillips screwdriver
Flat-tip screwdriver
Stubby Phillips screwdriver
10 mm combination wrench
Clip remover
8 mm and 10 mm Sockets
Ratchet
Small flat-tip screwdriver
Contact cleaner
Shop towel

Illustration of the CD Changer Installed on the Vehicle

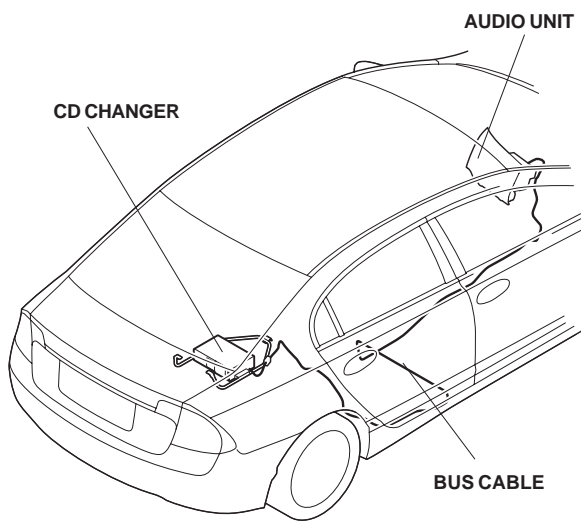

INSTALLATION

Customer Information: The information in this installation instruction is intended for use only by skilled technicians who have the proper tools, equipment, and training to correctly and safely add equipment to your car. These procedures should not be attempted by "do-it-yourselfers."

Routing the Fog Light Harness

1. Make sure you have the anti-theft code for the radio, then write down the frequencies for the preset buttons.
2. Disconnect the negative cable from the battery.

3. Inside the passenger's compartment area, remove the rear seat cushion by removing the bolt and releasing the two hooks.

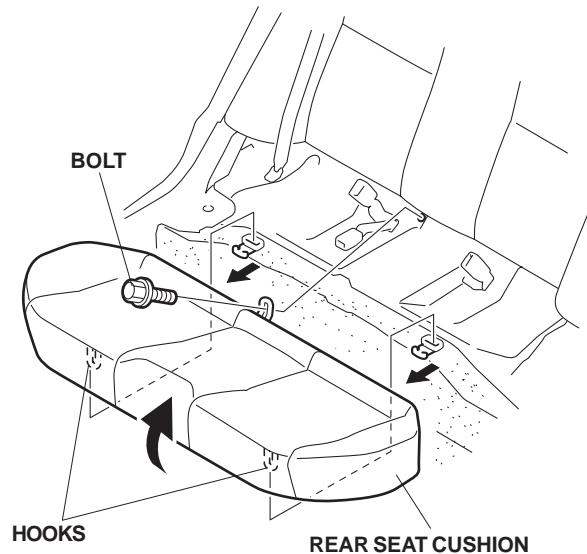

4. Remove the right rear seatback side frame by removing the bolt.

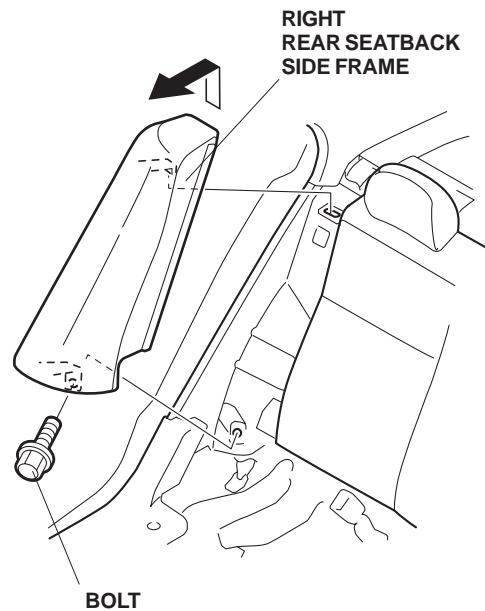

- Open the trunk lid, and remove the trunk floor by removing the two clips.

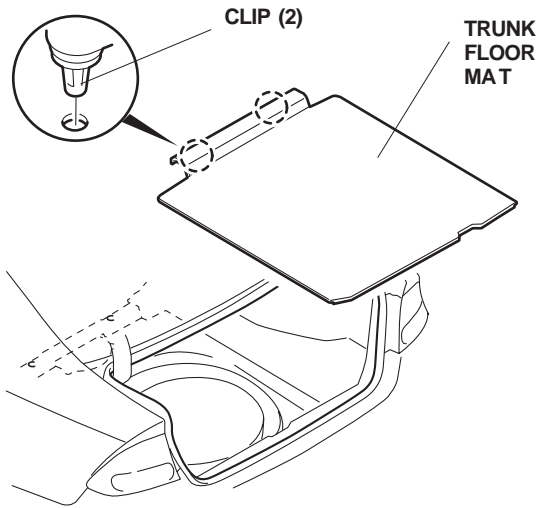

- Remove the trunk weatherstrip from the edge of the trunk opening in the area shown.
- Remove the rear trim panel by removing the four clips and releasing the two hooks.

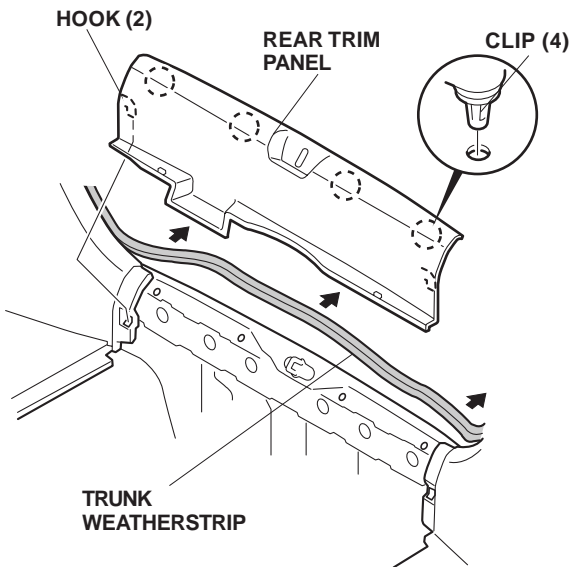

- Inside the trunk room, fold the right rear seatback forward by pulling the lever under the rear parcel shelf.
- Continue removing the weatherstrip in the area shown. Remove the five clips, then pull out on the right trunk side trim panel in the direction shown.

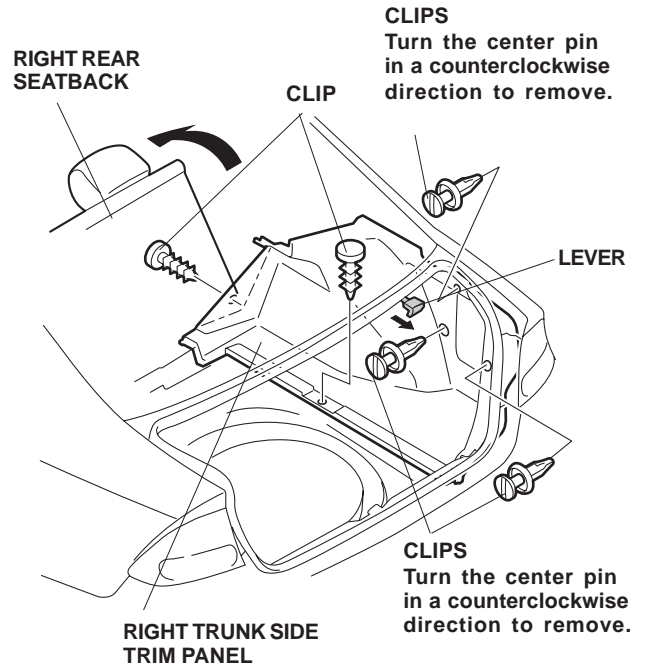

10. Remove the center console cover.
 - Pull down on the shift boot, then loosen the fastening nut by turning it counterclockwise.
 - Remove the shift knob by turning it counterclockwise. Remove the fastening nut by turning it clockwise.
 - Remove the center console cover by removing the three clips that fasten the center console cover.
11. Open the center console lid, and remove the mat.
12. Remove the two self-tapping screws, two screws and two clips that fasten the center console, then

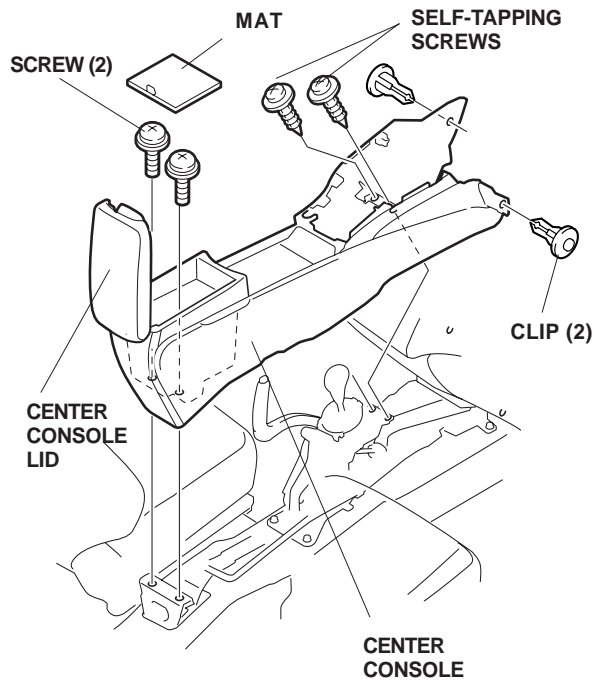

remove the center console.

13. Turn the knob counterclockwise, release the two clips and remove the instrument under cover by lowering the cover a little, then pulling it toward you. Take care not to damage the clips.

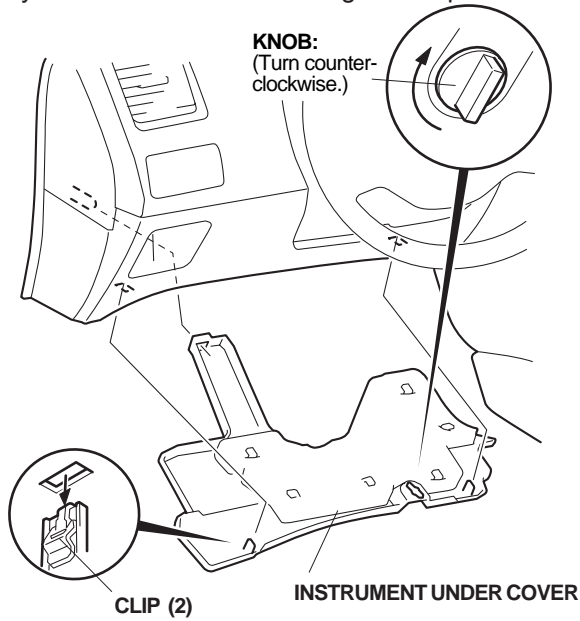

14. Release the eight clips, and remove the instrument lower cover by pulling it toward you. Take care not to damage the clips.

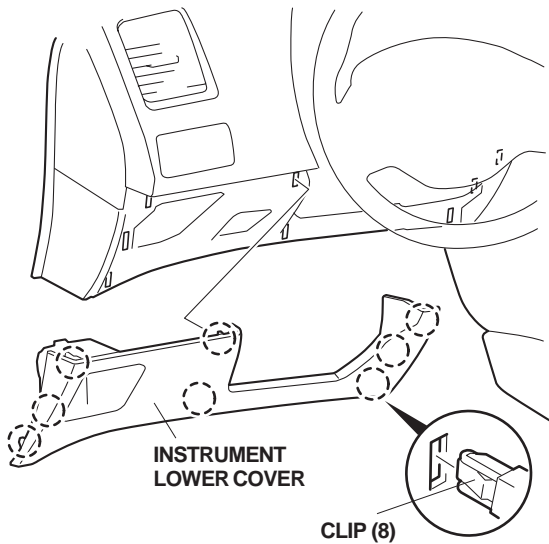

15. Release the four clips, and remove the assistant lower cover by pulling it toward you. Take care not to damage the clips and pins.

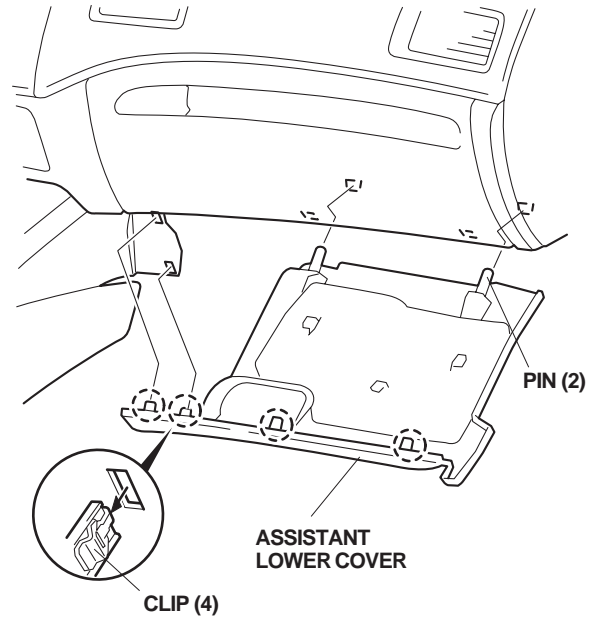

16. Release the two hooks and remove the lid above the front console pocket.

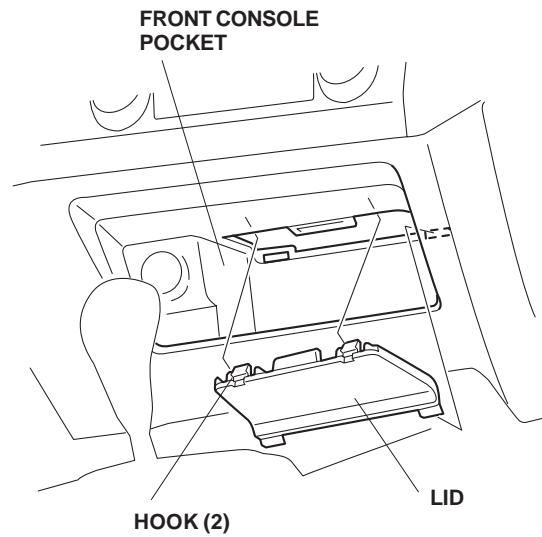

17. Remove the two bolts from the bottom of the center panel.
18. Release the ten retaining clips, and pull the center panel toward you.
19. Unplug the right vehicle connectors, then remove the center panel.

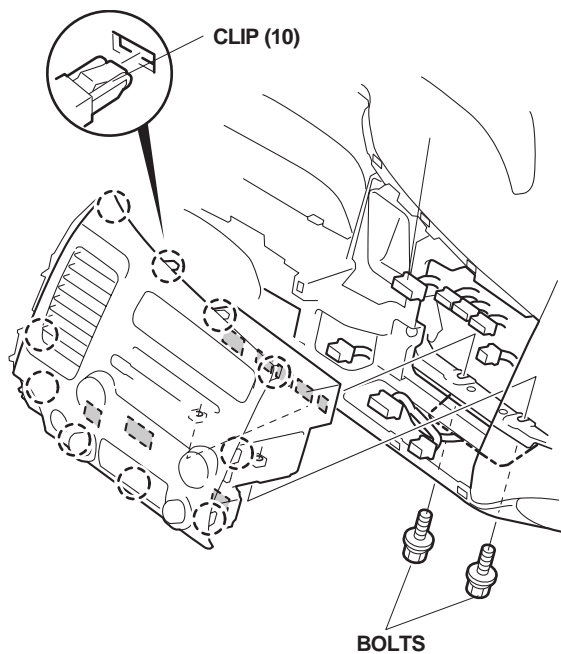

Routing the BUS cable

20. Route the BUS cable along the vehicle harness from the trunk side.

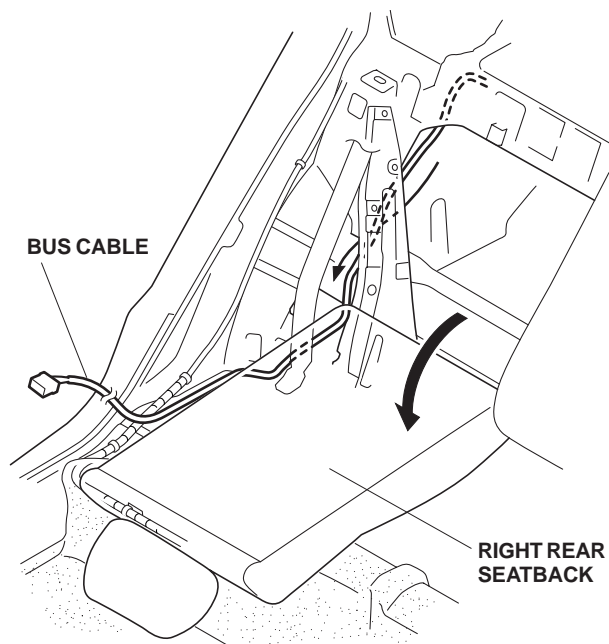

21. Return the right rear seatback, then remove the clip securing the floor carpet. Turn over the floor carpet.
22. Route the BUS cable connector as shown.

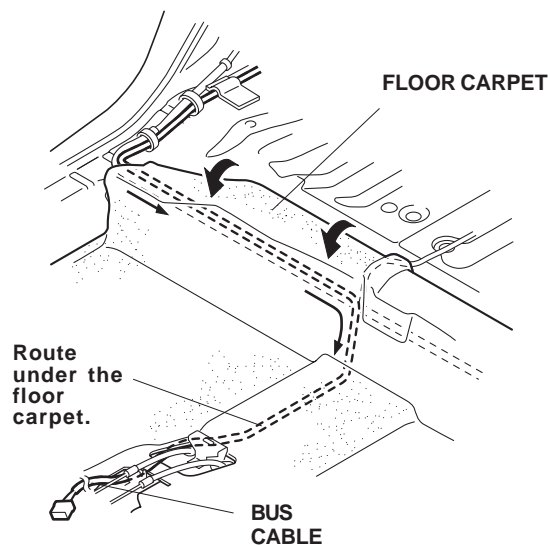

23. Route the BUS cable forward to the right front console frame along the vehicle harness.
24. Route the BUS cable connector to the dashboard and out through the dash opening.

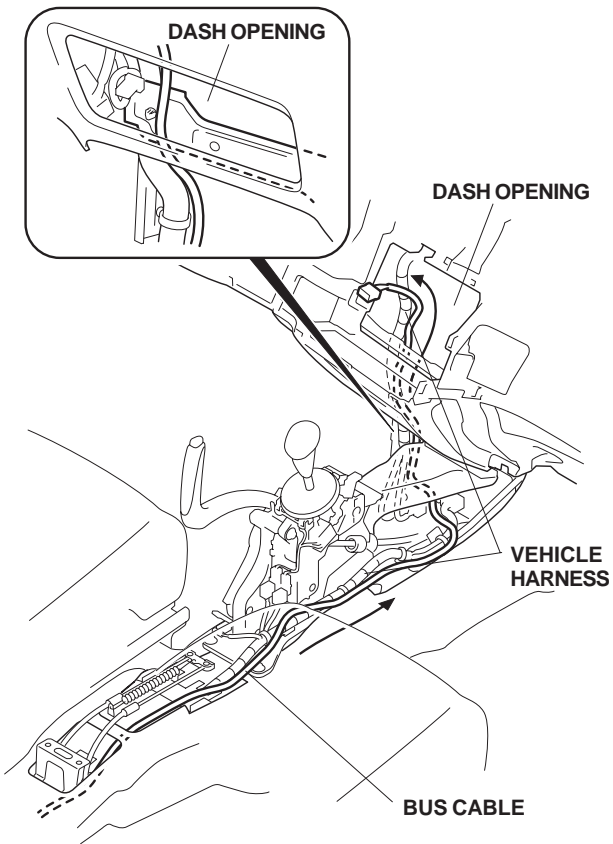

25. Measure 300 mm from the end of the BUS cable connector, then secure the BUS cable to the vehicle harness with three wire ties.

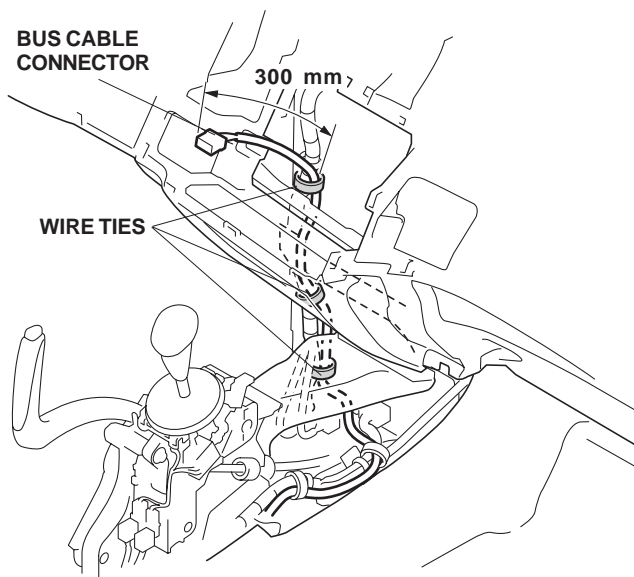

26. Secure the BUS cable to the vehicle harness with five wire ties.
27. Using isopropyl alcohol on a shop towel, clean the area where the cushion tape will attach. Attach the BUS cable to the floor panel with the two cushion tapes in the area shown.

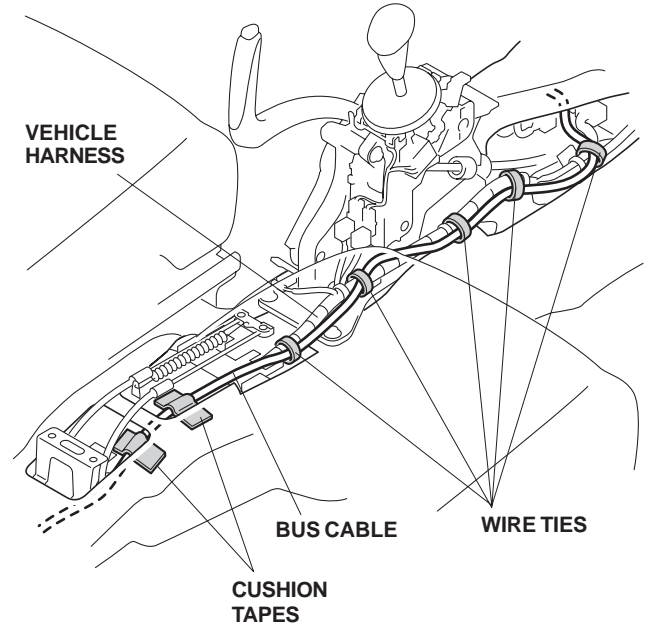

With the vehicle bracket

- Using isopropyl alcohol on a shop towel, clean the inside of the vehicle bracket where the cushion tape attaches. Attach the cushion tape on the vehicle bracket at the location shown.

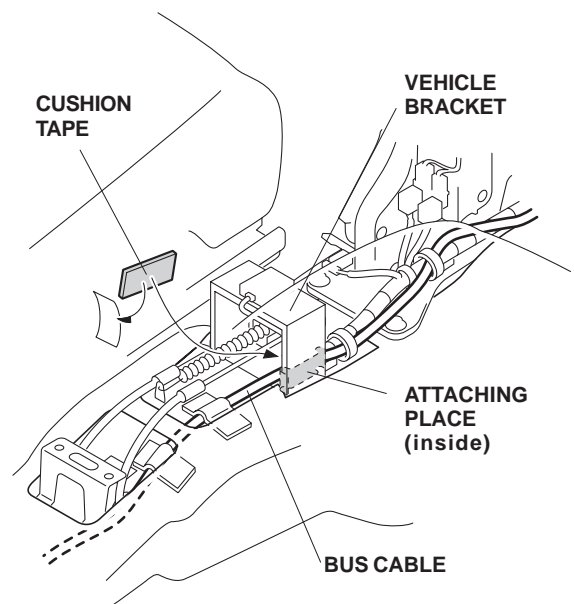

28. Turn over the floor carpet, and attach the BUS cable to the floor panel with the two cushion tapes in the areas shown.
29. Secure the BUS cable to the vehicle harness with the three wire ties in the areas shown.

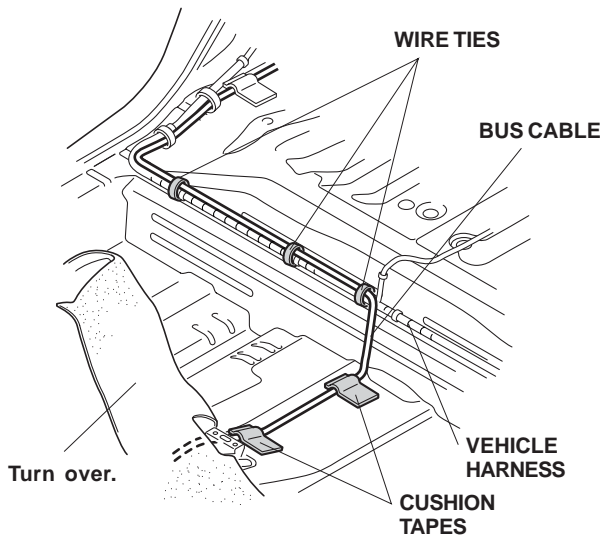

30. Secure the BUS cable to the vehicle harness with the two wire ties in the areas shown.
31. Attach the BUS cable to the floor panel with the four cushion tapes in the areas shown.

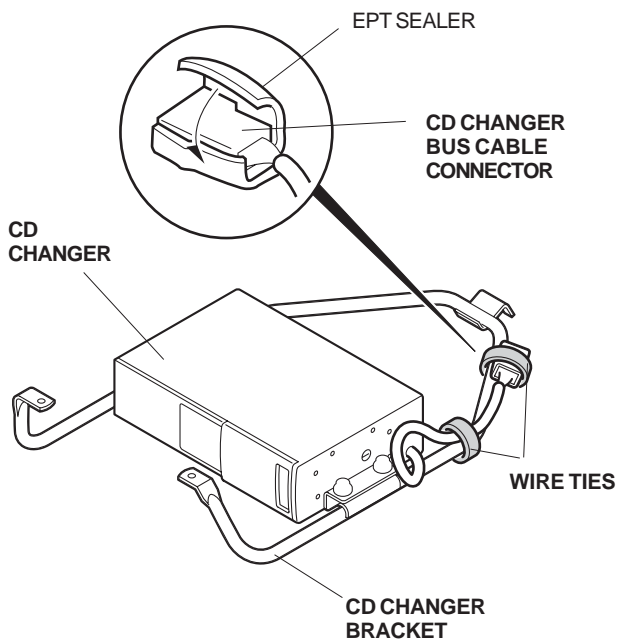

Installing the CD Changer

32. Carefully unpack the CD changer.

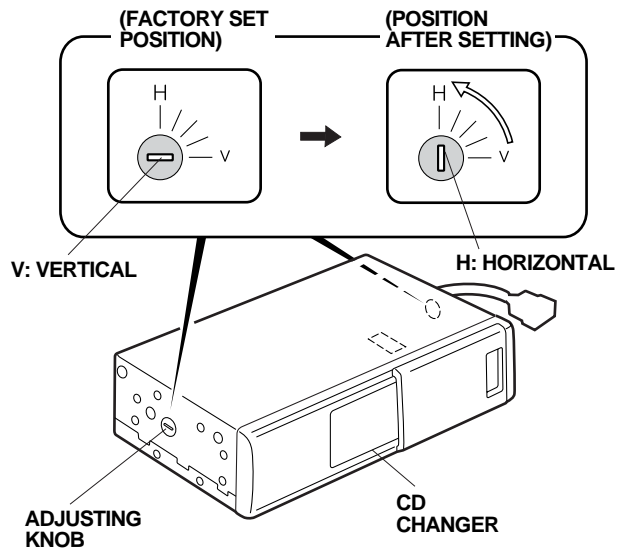

33. The adjustment knobs have been set to the vertical (V) position before shipping the CD changer from the factory. Move the adjustment knobs to the horizontal (H) position using a small flat-tip screwdriver.
34. Position the CD changer brackets on the sides of the CD changer, then install the four 4 x 8 mm washer-screws.

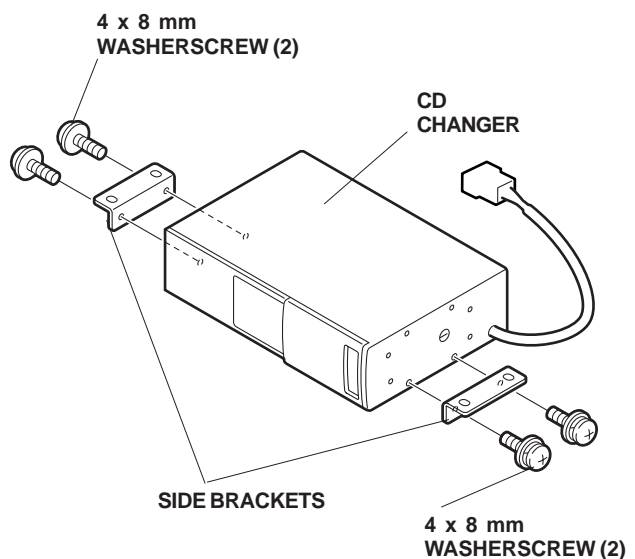

35. Position the CD changer on the CD changer bracket, then install and tighten the four 6 mm flange nuts.

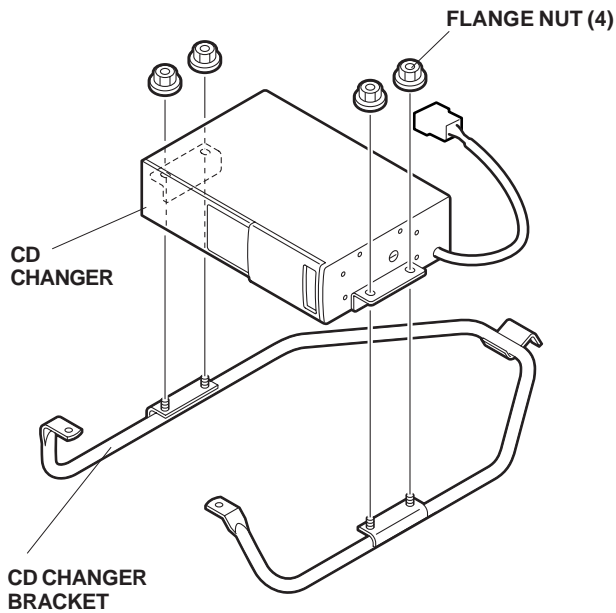

36. Wrap one EPT sealer around the BUS cable connector from the CD changer, then secure the BUS cable and connector to the CD changer bracket with the two wire ties you just installed.

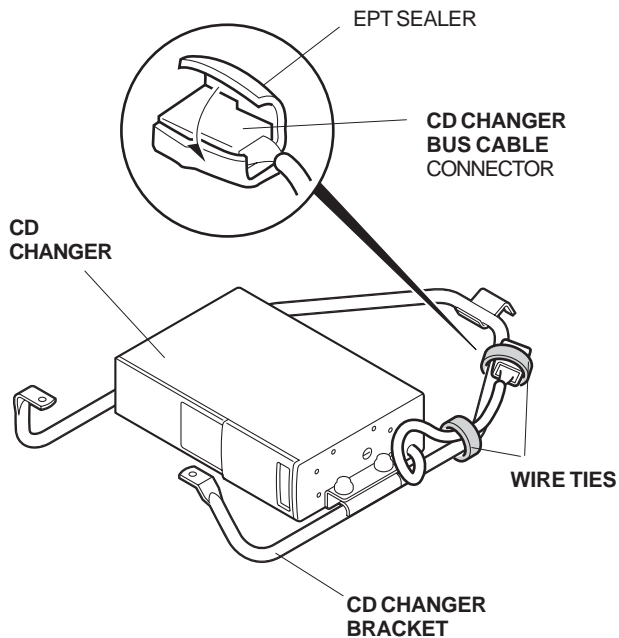

37. In the trunk, slide the clip nut into position on the rear seat panel through the hole in the panel. If necessary, spread the clip nuts open with a small flat-tip screwdriver.
38. Loosely install the washer-bolt to the rear seat panel first. Then place the end of the CD changer bracket between the seat panel and the clip nut you just installed.

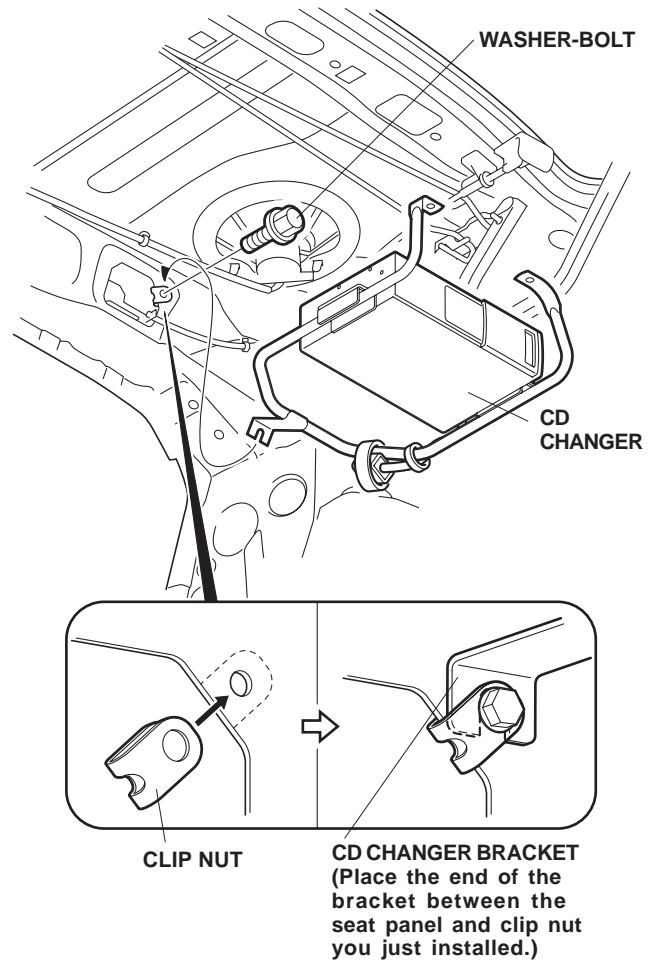

39. Slide the two clip nuts onto the CD changer brackets and parcel shelf through the holes in the parcel shelf, and align their holes as shown. Install the two washer-bolts, and tighten them securely.

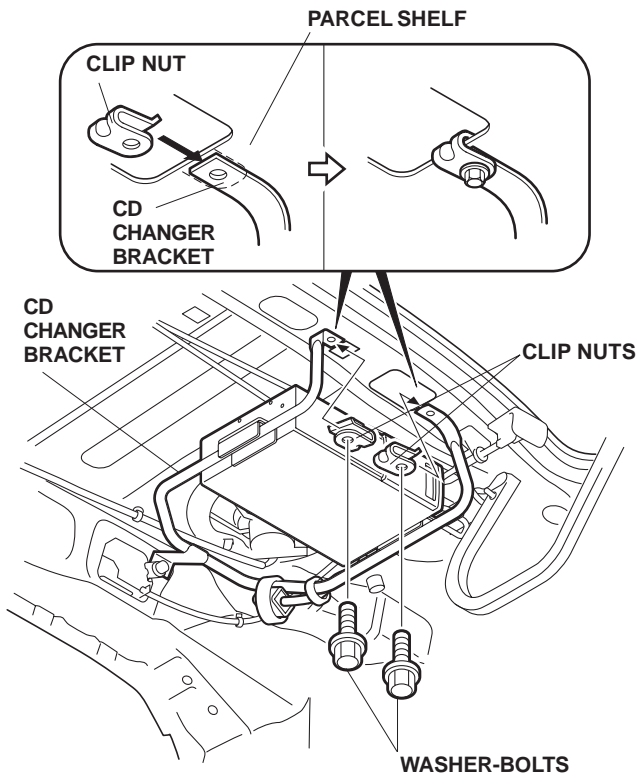

40. Connect the BUS cable connector to the CD changer connector from the CD changer.

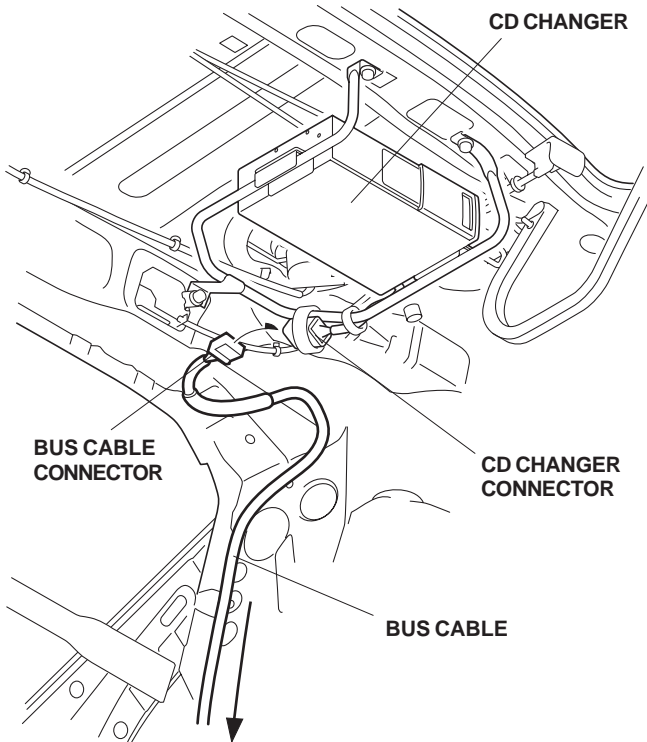

41. Fold the excess BUS cable and secure the BUS cable to the holes of the rear seat panel with the two wire ties with clip.

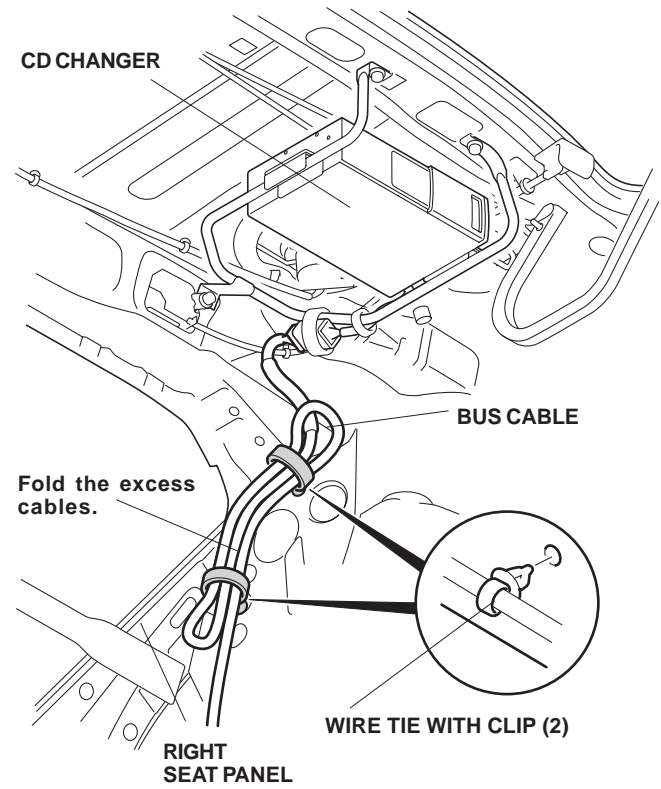

42. Plug the BUS cable connector, vehicle 20-pin connector (blue), and antenna lead into the rear of the audio unit.

STANDARD AUDIO UNIT

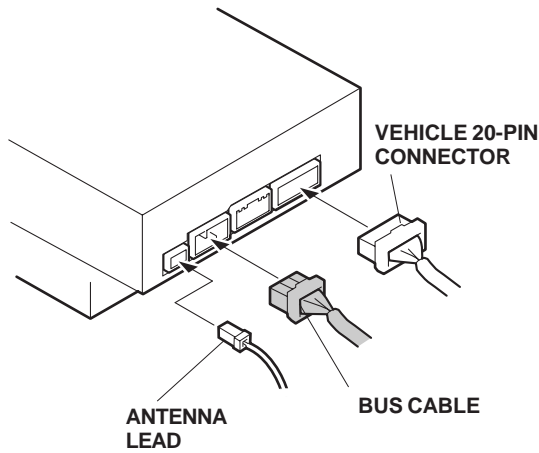

MULTI CONTROL CD TUNER UNIT

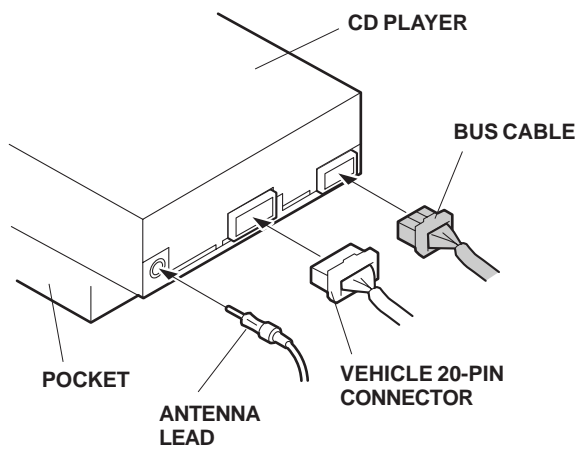

NAVIGATION HEAD UNIT

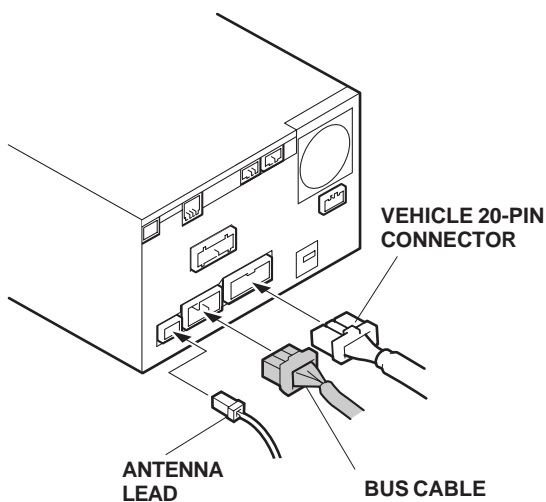

43. Connect the four vehicle connectors to the center panel, and reinstall the center panel.

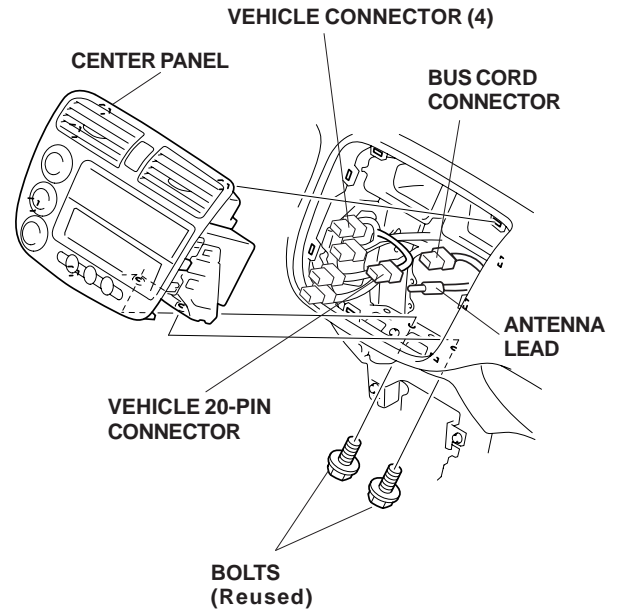

44. Check that all wire harnesses are routed properly and that all connectors are plugged in.
45. Reconnect the negative cable to the battery.
46. Reset the clock and the radio station presets.
47. Check the operation of the CD changer as described in the owner's manual supplied.
48. Reinstall all removed parts. Be sure that all retaining clips and tabs are securely fastened.
49. Put the CD changer Accessory owner's information manual in the glove box for your customer.

NOTE: Whenever the battery is disconnected, the driver's window AUTO function is disabled.

50. Start the engine. Push down on the driver's window switch until the window is fully open.
51. Pull up on the driver's window switch to close the window completely, then hold the switch for 2 seconds.
52. Lower and raise the driver's window to check operation of the driver's window AUTO function.