



INSTALLATION INSTRUCTIONS

Accessory

INTERIOR PANEL KIT

Application

2007 CIVIC
HYBRID

Publications No.

All 33831

Issue Date

SEP 2006

PARTS LIST

Meter panel

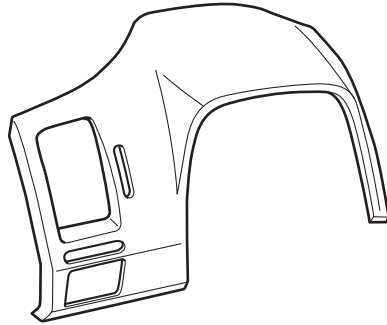

Center panel

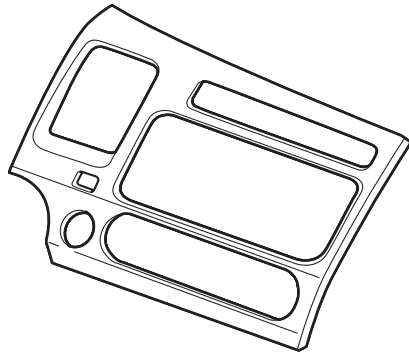

Outlet panel "A"

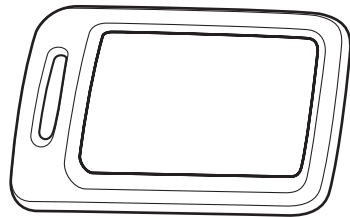

Outlet panel "B"

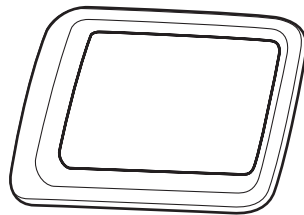

TOOLS REQUIRED

Isopropyl alcohol

Shop towel

Masking tape

INSTALLATION

NOTE:

- Be extremely careful not to damage the interior panel.
- Install the panel kit only if the ambient air temperature is above 60°F (15°C).

Installing the Meter Panel

1. Using isopropyl alcohol on a shop towel, clean the area where the meter panel will attach.
2. Attach a strip of masking tape to the end of each shaded adhesive backing. Peel back 2 in. (5 to 6 cm) of the adhesive backings, and fold them over as shown. Temporarily attach the strips of masking tape to the outside of the meter panel. Remove all remaining adhesive backings from the meter panel.

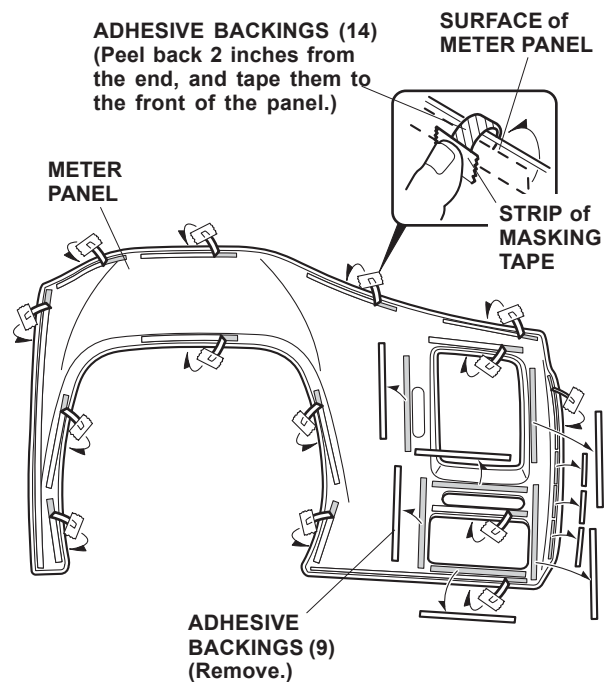

- Position the meter panel on the existing meter panel. While holding pressure on the meter panel, carefully remove the adhesive backings from the meter panel. Hold the meter panel firmly against the existing meter panel with the palm of your hand, particularly at the edges.

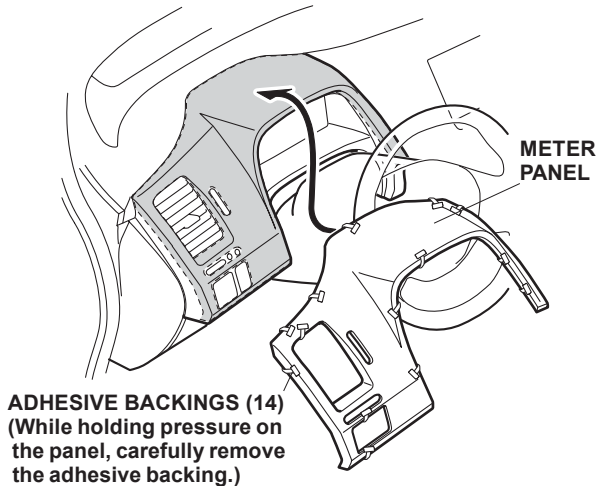

Installing the Center Panel

- Using isopropyl alcohol on a shop towel, clean the area where the center panel will attach.

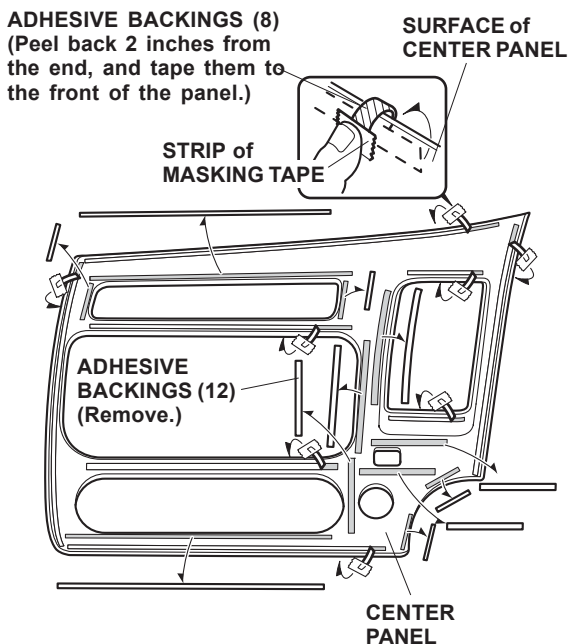

- Attach a strip of masking tape to the end of each shaded adhesive backing. Peel back 2 in. (5 to 6 cm) of the adhesive backings and fold them over as shown. Temporarily attach the strips of masking tape to the outside of the center panel. Remove all remaining adhesive backings from the center panel.

- Position the center panel on the existing center panel. While holding pressure on the center panel, carefully remove the adhesive backings from the center panel. Hold the center panel firmly against the existing center panel with the palm of your hand, particularly at the edges.

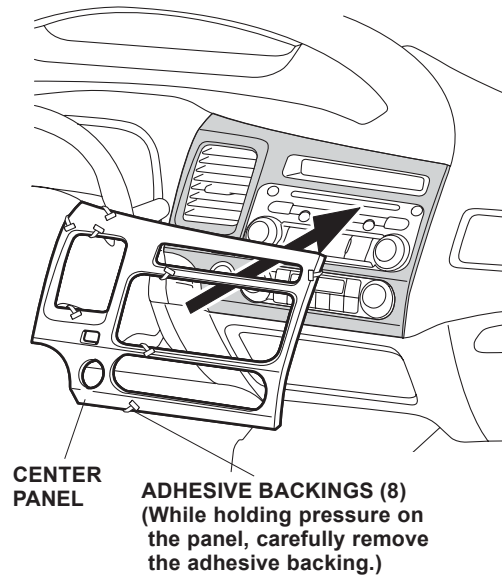

Installing the Outlet Panels

- Using isopropyl alcohol on a shop towel, clean the areas where the outlet panel will attach.

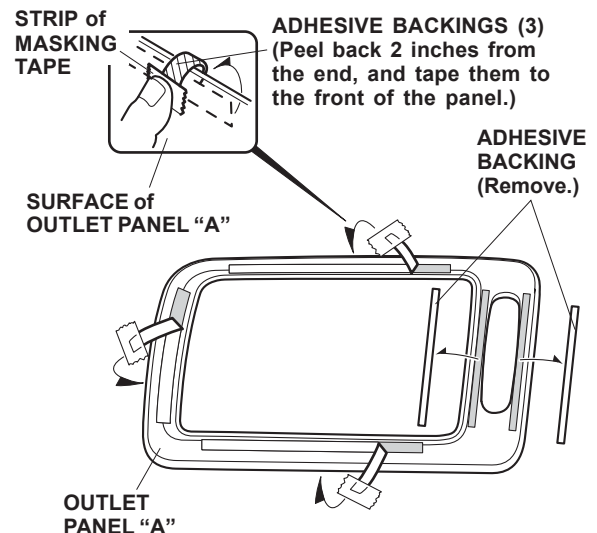

- Attach the strip of masking tape to the end of each shaded adhesive backing. Peel back 2 in. (5 to 6 cm) of the adhesive backings, and fold them over as shown. Temporarily attach the strips of masking tape to the outside of the outlet panel "A." Remove all remaining adhesive backings from the outlet panel "A."

9. Attach a strip of masking tape to the end of each shaded adhesive backing. Peel back 2 in. (5 to 6 cm) of the adhesive backings and fold them over as shown. Temporarily attach the strips of masking tape to the outside of the outlet panel "B."

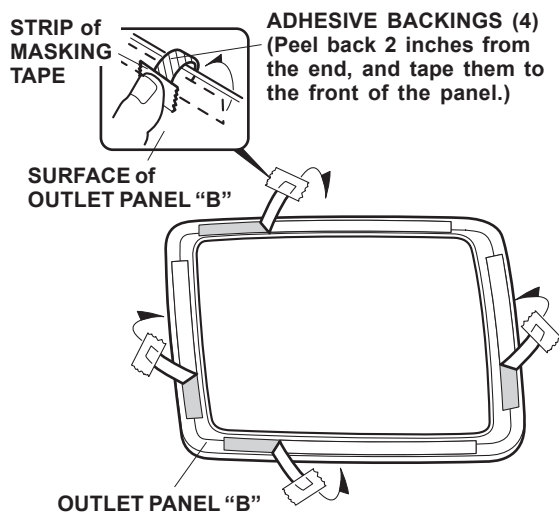

10. Position the outlet panels "A" and "B" on the existing outlet panels. While holding pressure on the outlet panels, carefully remove the adhesive backings from the outlet panels. Hold the outlet panels "A" and "B" firmly against the existing outlet panels with the palm of your hand, particularly at the edges.

