



INSTALLATION INSTRUCTIONS

| | | |
|------------------------|-------------------|------------------------|
| Accessory | Application | Publications No. |
| SECURITY SYSTEM | 2006 S2000 | All 31073-31404 |
| | | Issue Date |
| | | OCT 2005 |

PARTS LIST

Security System:
P/N 08E51-S84-100

2 Remote controls

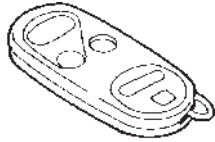

Control unit

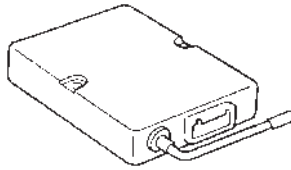

LED
(Not used.)



Push nut
(Not used.)



2-Pin connector

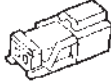

Disarm switch



Window decal



3-Pin connector
(Not used.)

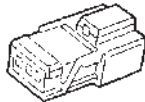

Nut



Washer



User's Information



2 Washer-screws, 4 x 30 mm



Attachment Kit: P/N 08E55-S2A-100A

Security system harness

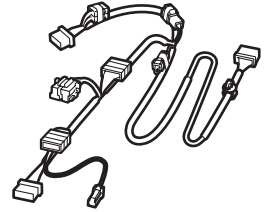

Control unit bracket

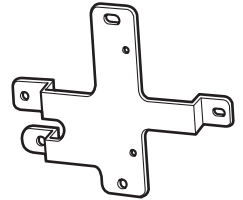

Relay A (black)

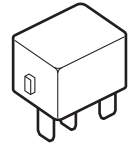

Relay B (gray)

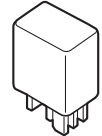

Fuse label

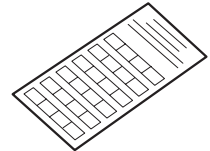

3 Grommets

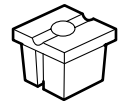

3 Self-tapping screws



11 Wire ties

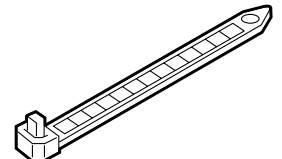

Wire tie with clip

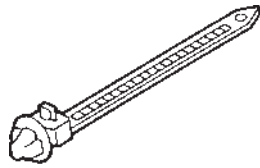

2 Flange nuts



EPT sealer

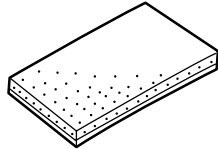

TOOLS AND SUPPLIES REQUIRED

- Small flat-tip screwdriver
- Phillips screwdriver
- Center punch
- Eye protection (face shield, safety goggles, etc.)
- Drill
- 5.5 mm Drill bit
- 12 mm Holesaw
- Tape measure
- File
- Felt-tip pen
- Ratchet
- 10 mm, 12 mm, and 14 mm Sockets
- Piece of cardboard
- Diagonal cutters
- Electrical tape
- Torque wrench
- Shop towel

Illustration of Security System Installed on the Car

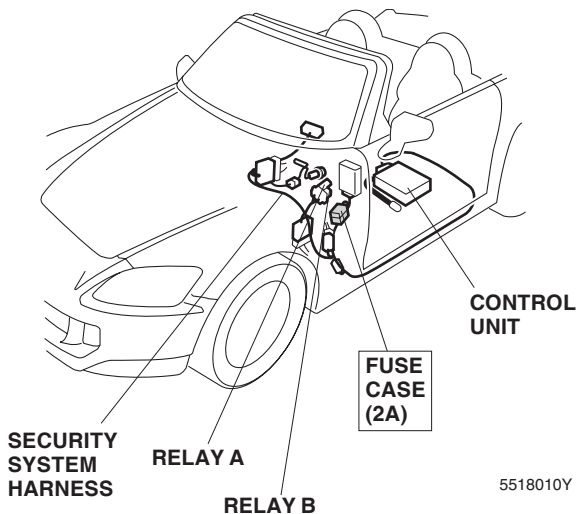

Adjusting the Control Unit

Use a small flat-tip screwdriver to change the mode switch and the horn/siren switch and to adjust sensitivity. The horn/siren switch must be set in the "HORN" position.

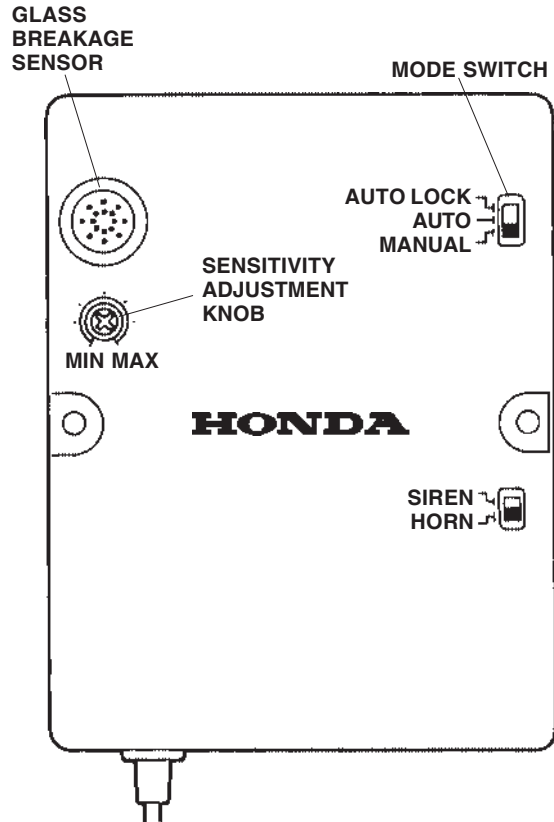

Mode Switch:

- Set the mode switch according to the customer's choice.
- Refer to the owner's manual for the explanation of each mode.

Glass Breakage Sensor:

Do not attach anything like adhesive tape over the holes; this is a microphone pickup.

Sensitivity Adjustment Knob:

- Adjust the sensitivity only if the customer requests it; the sensitivity adjustment of the glass breakage sensor is factory-set.
- Be careful when you adjust the sensitivity; if you raise the sensitivity too much, the security system can give a false alarm, and if the sensitivity is too low, the security system may not work even if glass is broken.

INSTALLATION

Customer Information: The information in this installation instruction is intended for use only by skilled technicians who have the proper tools, equipment, and training to correctly and safely add equipment to your vehicle. These procedures should not be attempted by “do-it-yourselfers.”

1. Make sure you have the anti-theft code for the radio, then write down the radio station presets.
2. Disconnect the negative cable from the battery.
3. Remove the front left door sill trim (three retaining clips).

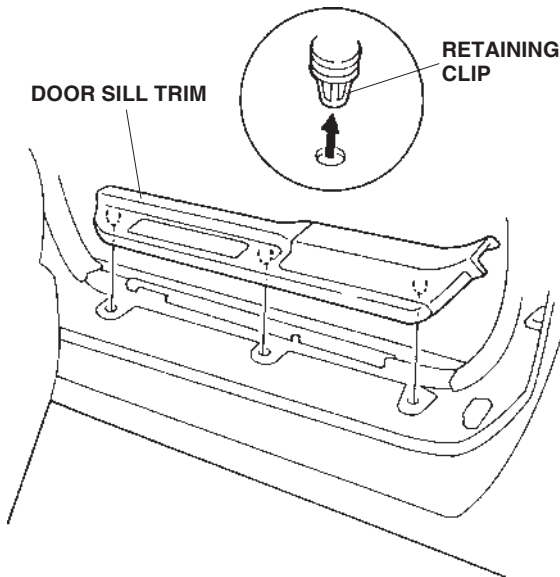

4. Remove the left kick panel (three clips).

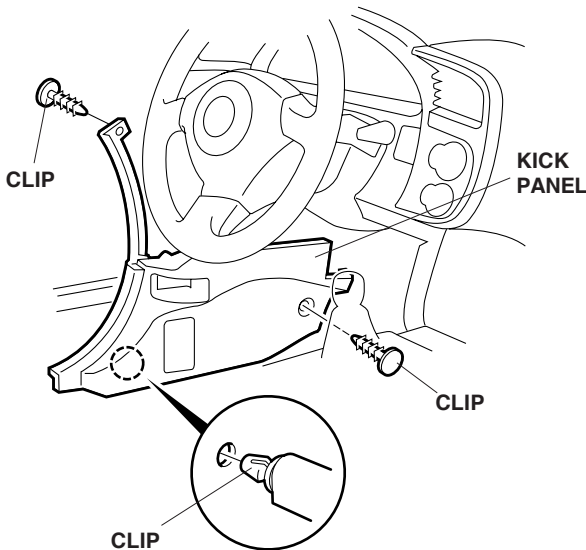

5. Remove the lower steering column cover (three screws, and pull gently to release the four tabs).

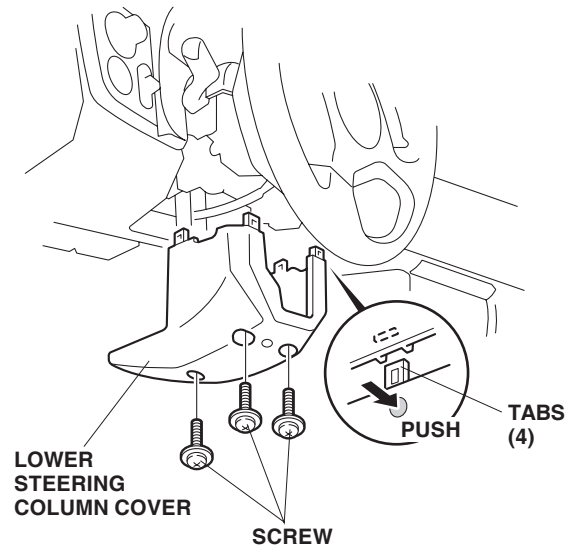

6. Remove the driver's lower cover (turn the knob clockwise, and nine clips).

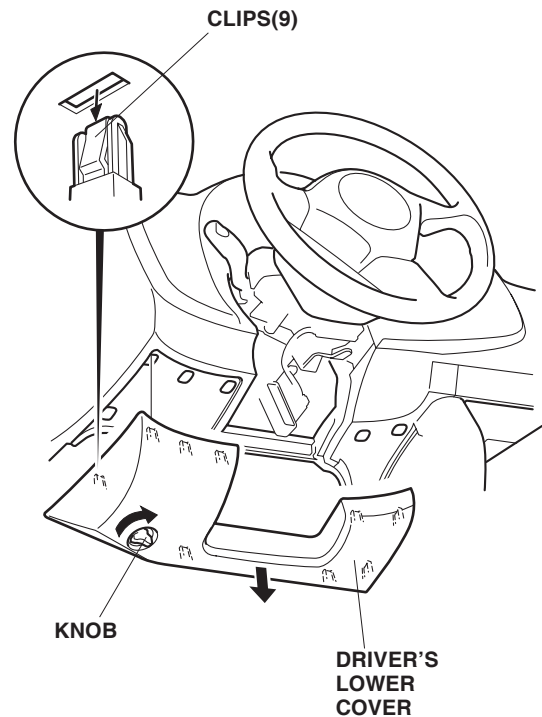

- Remove the driver's seat (four bolts, and unplug the two connectors). Place the seat on a piece of cardboard.

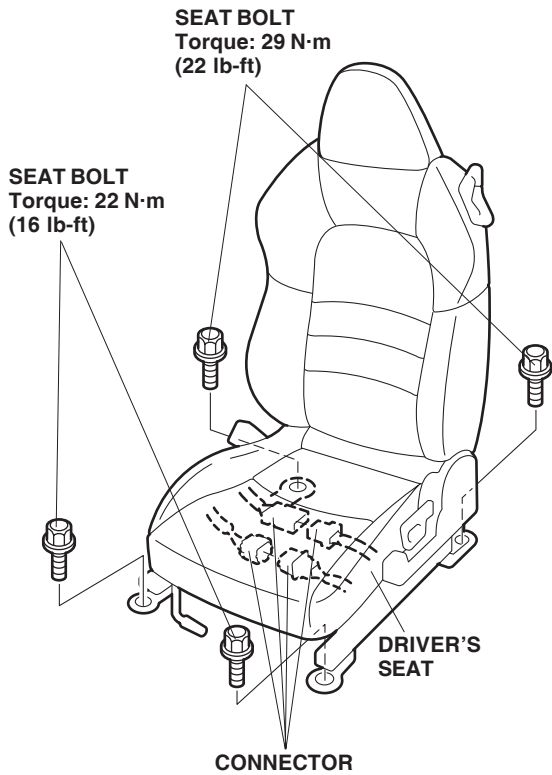

- To prevent damages to the vehicle, cover four ends of the seat rail with a towel.

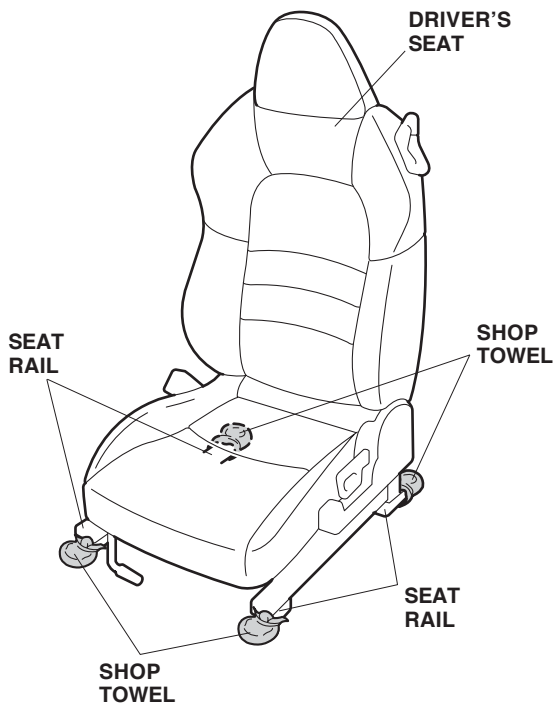

- Push the three grommets into the square holes in the bottom of the driver's seat cushion.

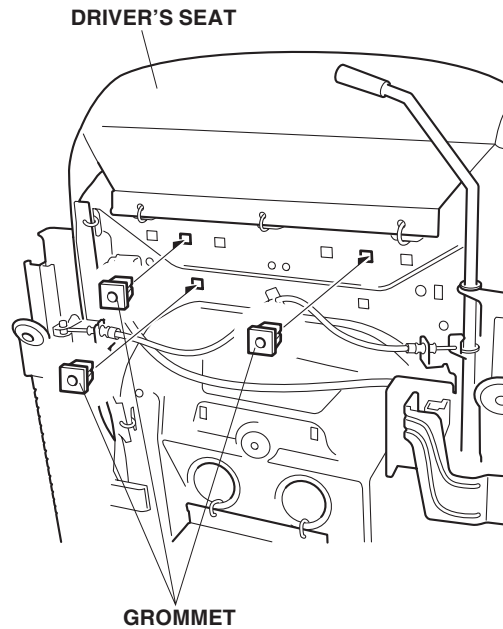

- Install the control unit on the control unit bracket (two 4 x 30 mm screws and two flange nuts).

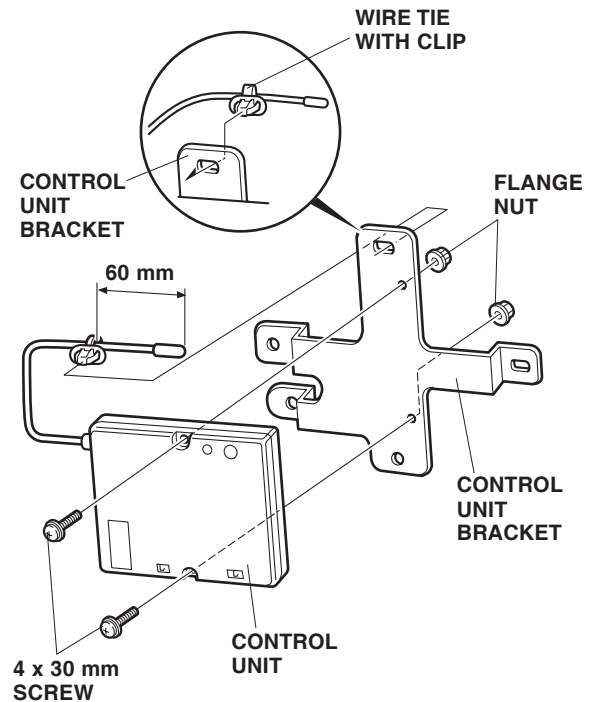

- Attach the wire tie with clip to the antenna, then push the clip into the hole in the control unit bracket.

12. Attach EPT sealer to the control unit bracket.

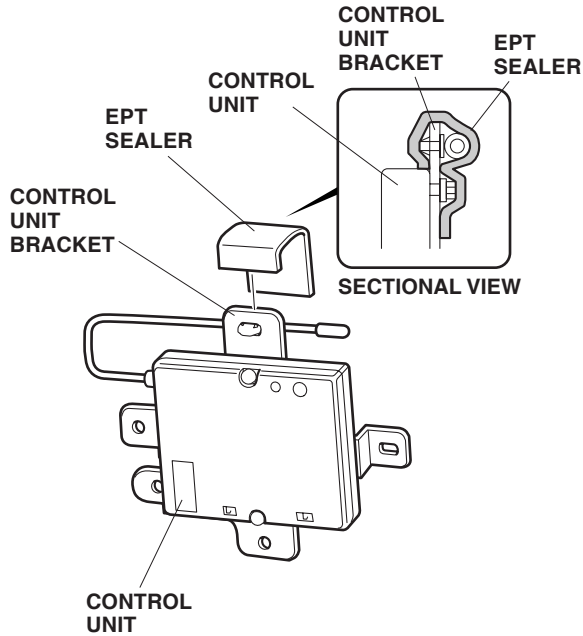

13. Install the control unit bracket onto the bottom of the driver's seat cushion (three self-tapping screws).

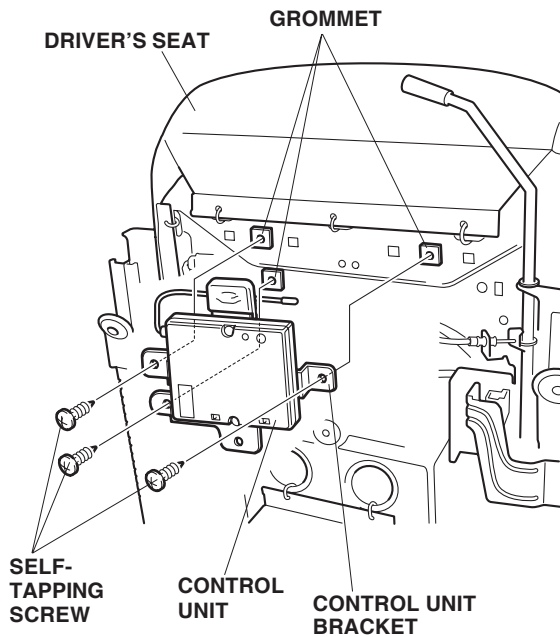

14. Mark the driver's lower cover in the position shown.

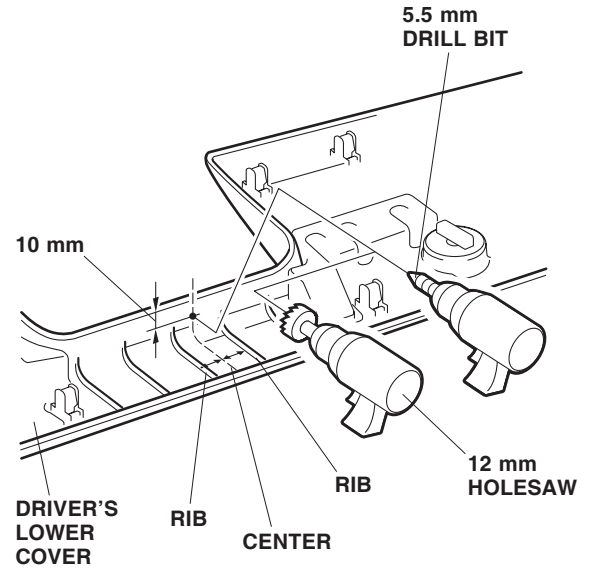

15. While wearing eye protection, lightly center-punch the mark, and drill a 12 mm hole:

- First drill a pilot hole with a 5.5 mm bit, then finish with a 12 mm bit.
- Remove all burrs.

16. Route the terminal ends of the disarm switch through the hole you just drilled, and secure it with the washer and the flange nut from the kit.

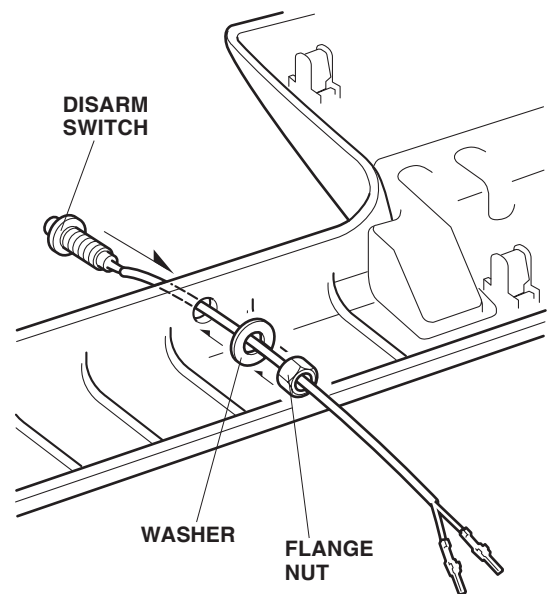

17. Get the 2-pin connector included in the kit. Firmly push the disarm switch terminals into the 2-pin connector until they click into position, then lower the lock.

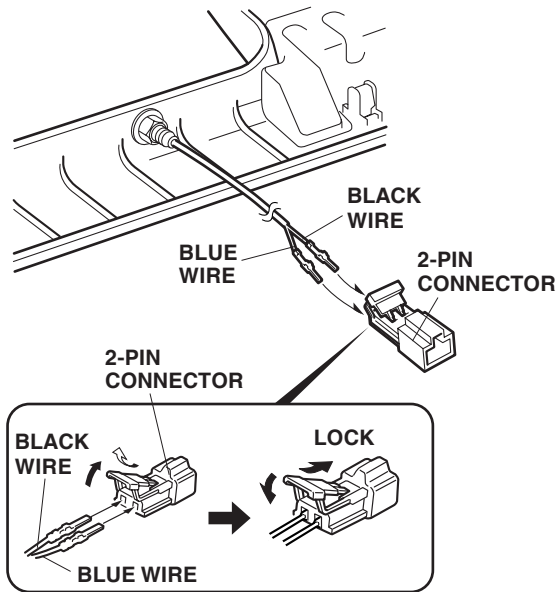

18. On the driver's side, lift up the floor carpet, then route the 22-pin (green) connector of the security system harness out through the cutout in the floor carpet.

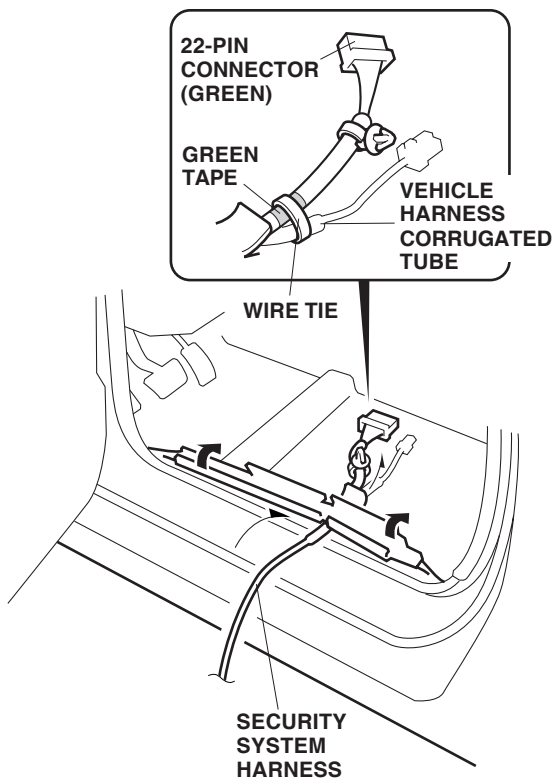

19. Align the green tape of the security system harness with the corrugated tube of the vehicle harness, then secure them with one wire tie.

20. Along the door opening, secure the security system harness to the vehicle harness with two wire ties.

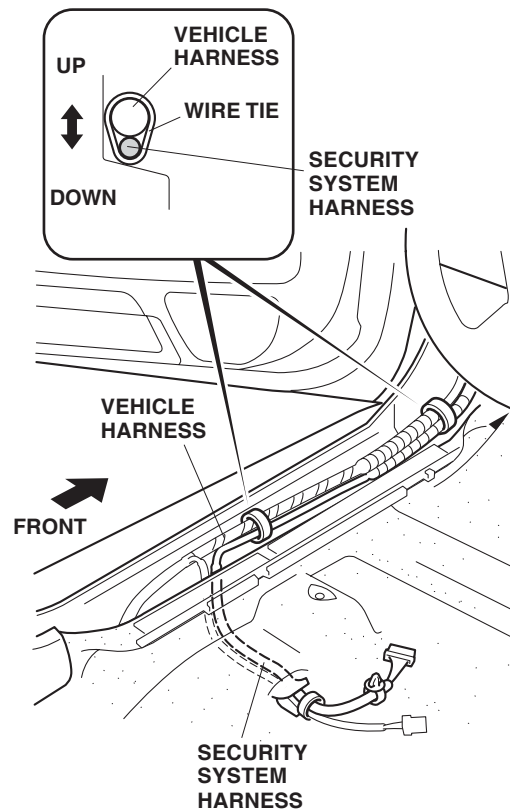

21. Route the security system harness forward and under the carpet.

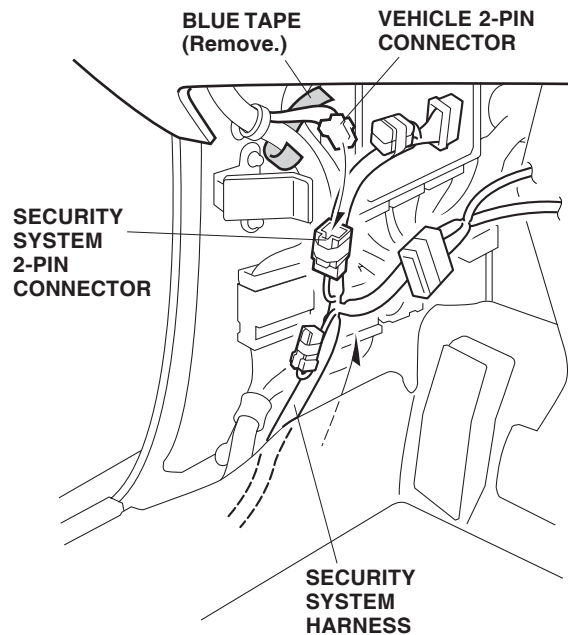

22. Remove the blue tape from the vehicle 2-pin connector, then connect vehicle 2-pin connector to the security system harness 2-pin connector.

23. Attach the two fuse labels (OPTION FUSE 3A) to the fuse case on the security system harness.

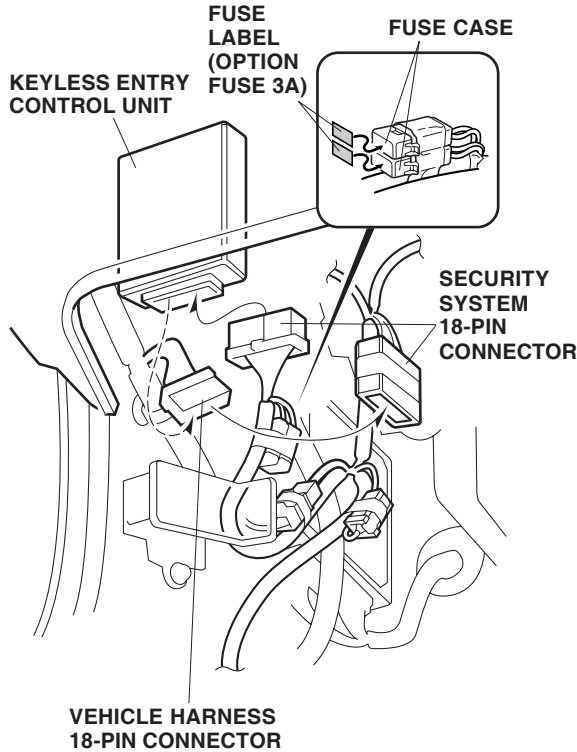

24. Unplug the vehicle 18-pin connector from the keyless entry control unit, and plug the 18-pin connectors of the security system harness in between.
25. Plug the relay A (black) and relay B (gray) into the security system harness relay block.

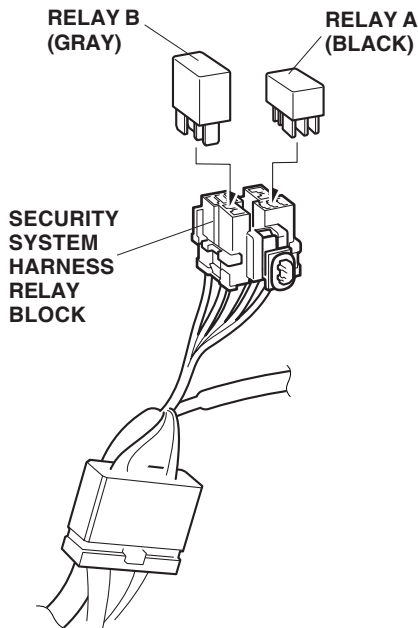

26. Install the clip of the security system harness on the vehicle frame.

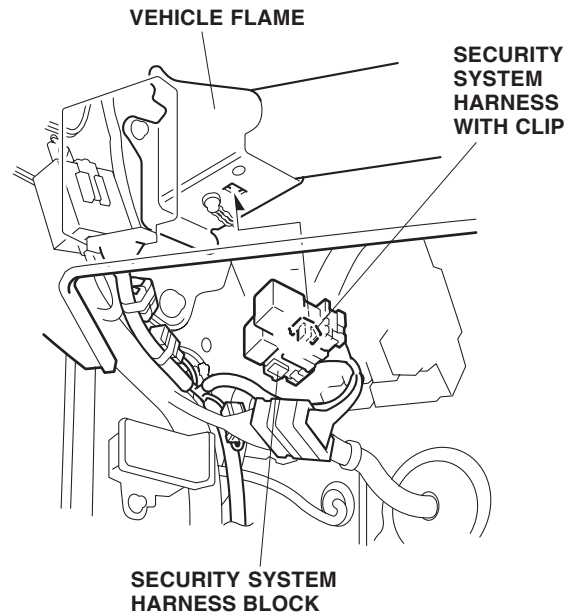

27. Unplug the light switch 16-pin connector, and plug the 16-pin connector of the security system harness in between.

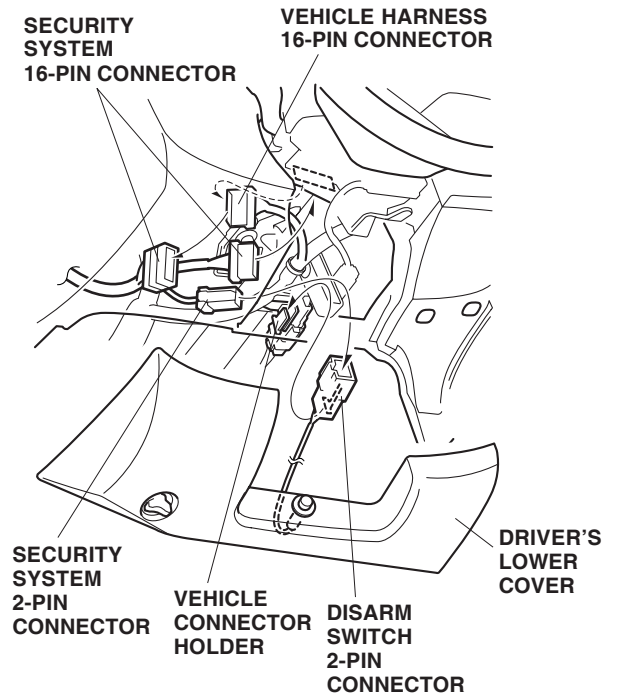

28. Plug the disarm switch 2-pin connector into the security system harness, then slide the 2-pin connector onto the vehicle connector holder.

29. Secure the security system harness to the vehicle harness with three wire ties.

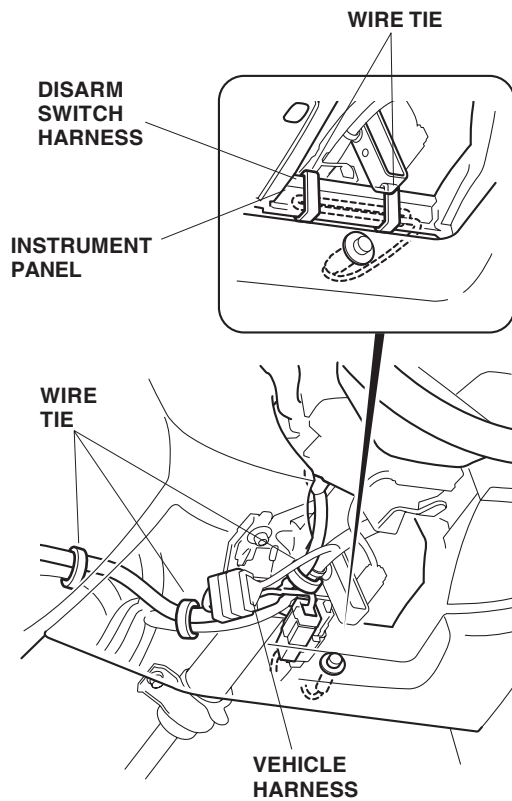

30. Reinstall the driver's lower cover.
31. Bundle the excess of the disarm switch harness and secure it to the instrument panel using two wire ties.
32. Secure the security system harness to the vehicle harness with three wire ties in the areas shown.

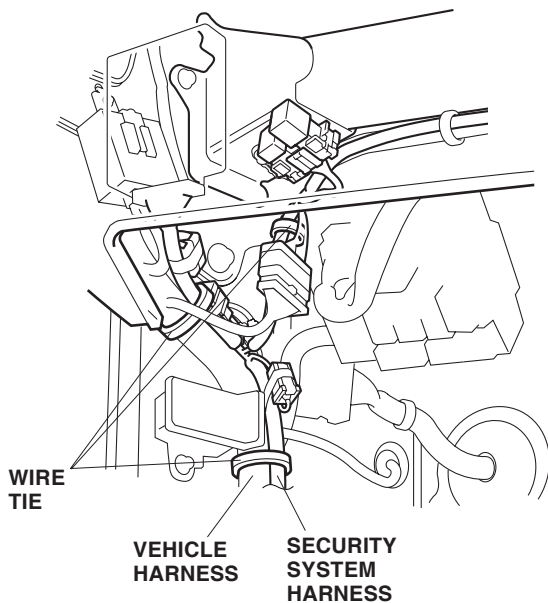

33. Tilt the driver's seat-back forward, then reach under the front of the seat, and plug the 22-pin connector (green) of the security system harness into the control unit.

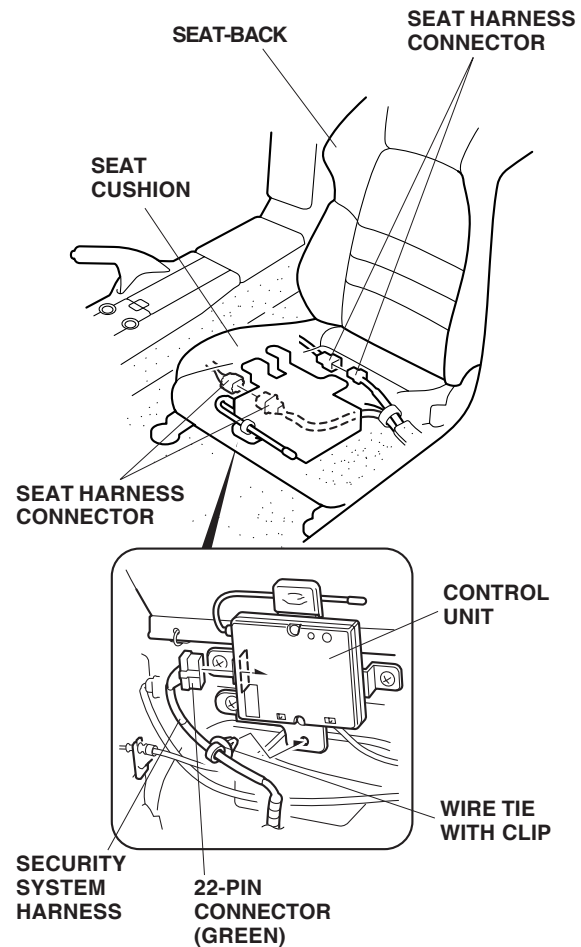

34. Push the wire tie with clip of the security system harness into the hole in the control unit bracket.
35. Plug in the seat harness connectors, then reinstall the driver's seat. Torque the rear seat bolts to 29 N·m (22 lb-ft), and torque the front seat bolts to 22 N·m (16 lb-ft).
36. Check that all wire harnesses are routed properly and all connectors are plugged in.
37. Reinstall all removed parts.
38. Reconnect the negative cable to the battery.
39. Reset the radio station presets and clock.
40. Check operation of the security system according to the security system User's Information. The LED indicator is located in the instrument cluster.