



INSTALLATION INSTRUCTIONS

Accessory

TRUNK SPOILER

Application

2006 S2000

Publications No.

All 31079

Issue Date

OCT 2005

PARTS LIST

Trunk spoiler

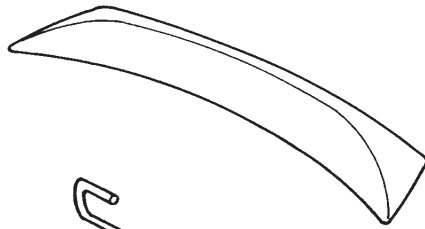

Right trunk spring
(with sponge tube)

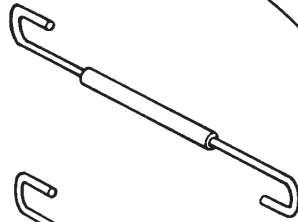

Left trunk spring

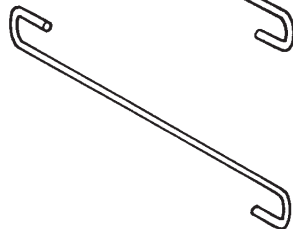

2 Cap nuts



2 Washer bolts



2 Butyl O-rings



4 Rubber washers



Marking washer set

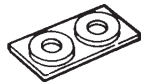

TOOLS AND SUPPLIES REQUIRED

Shop towel

Drill

Eye protection (face shield, safety goggles, etc.)

3 mm, 6 mm, and 8 mm Drill bits

File

Center punch

Touch-up paint

Heavy gloves

Trunk Spring Installer/Remover: T/N 08M10-SM4-100

Ratchet

6 mm Socket

Torque wrench

Hammer

Shop vacuum cleaner

INSTALLATION

Customer Information: The information in this installation instruction is intended for use only by skilled technicians who have the proper tools, equipment, and training to correctly and safely add equipment to your vehicle. These procedures should not be attempted by "do-it-yourselfers."

1. Wash and wax the area to be covered with a high-quality paste wax.

2. Inside the trunk lid, locate the identification hole on each side of the trunk lid. Center-punch each hole.

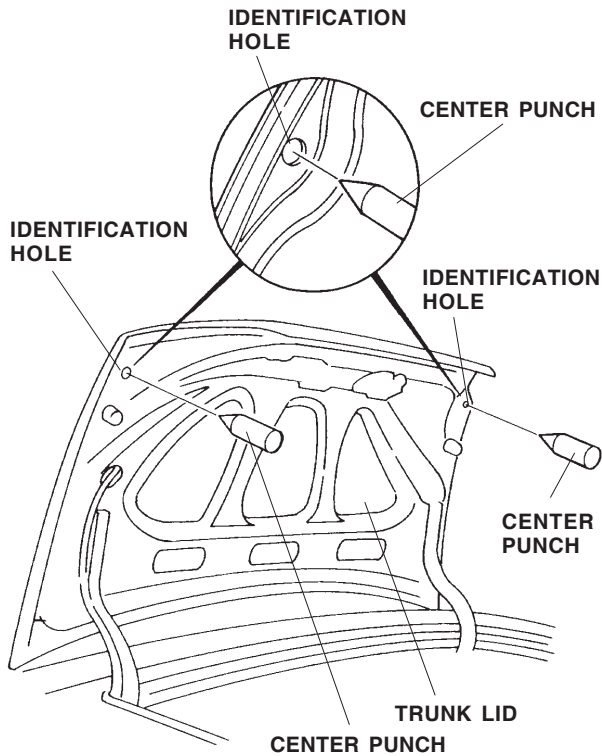

3. Cover the trunk with a drop cloth to catch any metal shavings.
4. While wearing eye protection, drill an 8 mm hole through each center-punched mark:
 - Start with a 3 mm drill bit, then use a 6 mm drill bit, and finish with an 8 mm drill bit.
 - Remove all burrs, and apply touch-up paint.

DRILL
(First drill with a 3 mm drill bit, then use a 6 mm drill bit, and finish with an 8 mm drill bit.)

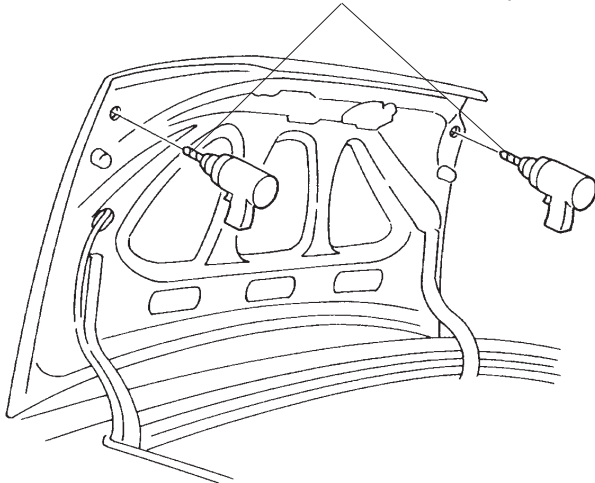

5. Remove the red adhesive backings from the two marking washers, and attach them to the trunk spoiler over the two screw holes.

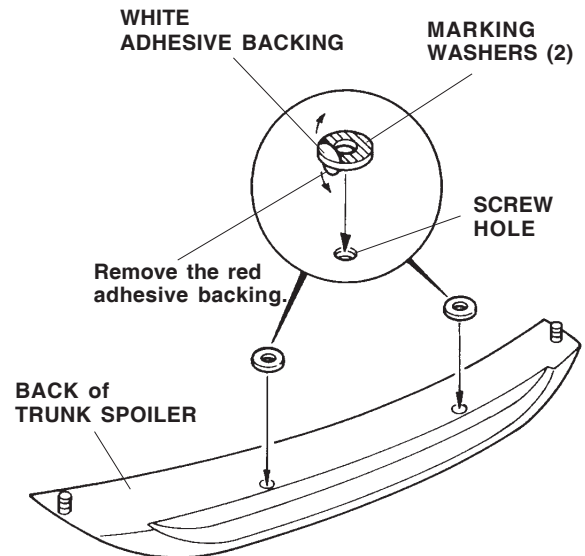

6. Remove the white adhesive backings from the marking washers. With the trunk lid closed, insert the studs from the trunk spoiler into the holes in the trunk lid.
7. Using the palm of your hand, press the trunk spoiler firmly against the trunk lid where the marking washers were attached. Apply pressure for about 30 seconds.

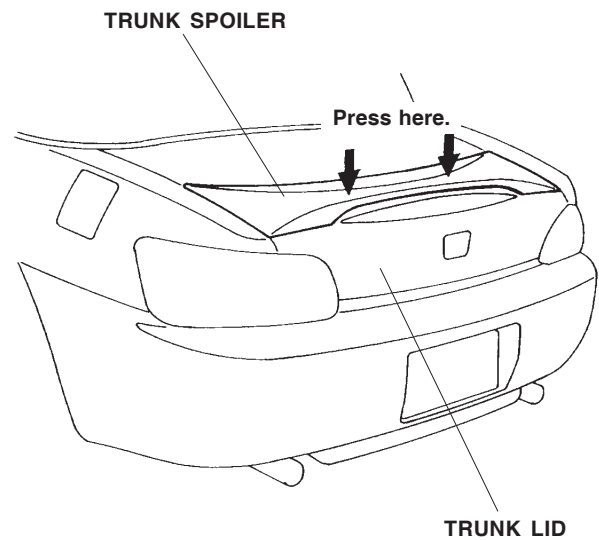

8. Slowly remove the trunk spoiler from the trunk lid. Check that the marking washers stay attached to the trunk lid.

- Lightly center-punch the trunk lid at the center of each marking washer attached to the trunk lid, then remove the marking washers.

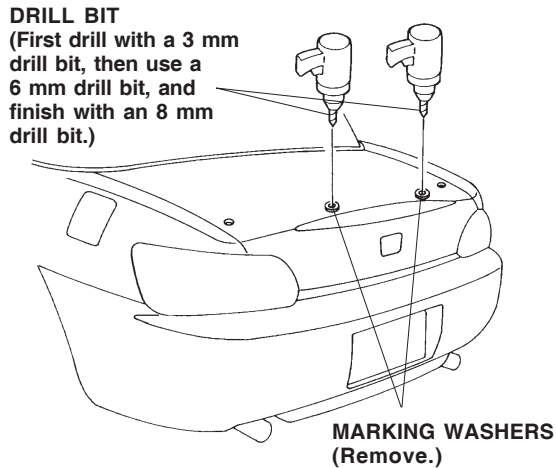

- While wearing eye protection, drill an 8 mm hole through each center-punched mark:
 - First drill with the 3 mm drill bit, then use a 6 mm drill bit, and finish with an 8 mm drill bit.
 - Remove all the burrs and metal shavings, and apply touch-up paint.
- Remove the adhesive backings from the four rubber washers, and attach them over the four holes in the trunk lid.

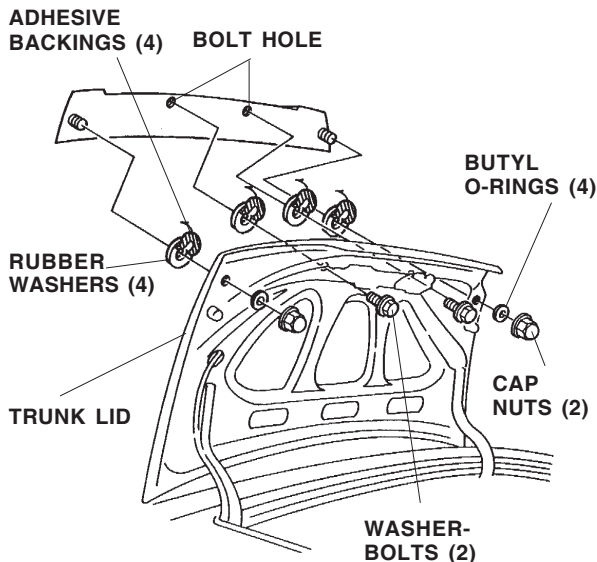

- Fit the trunk spoiler into position on the trunk lid. Install a butyl O-ring and a cap nut on the end of each stud, but don't tighten the cap nuts yet.
- Align the holes in the trunk spoiler with the holes in the trunk lid, and install the two washer bolts. Torque the cap nuts and washer bolts to 9 N•m (7 lb-ft).

- Remove the spare tire cover (three clips). Release the front portion of the left trunk side trim panel (three clips), and pull the panel away from the trunk springs.

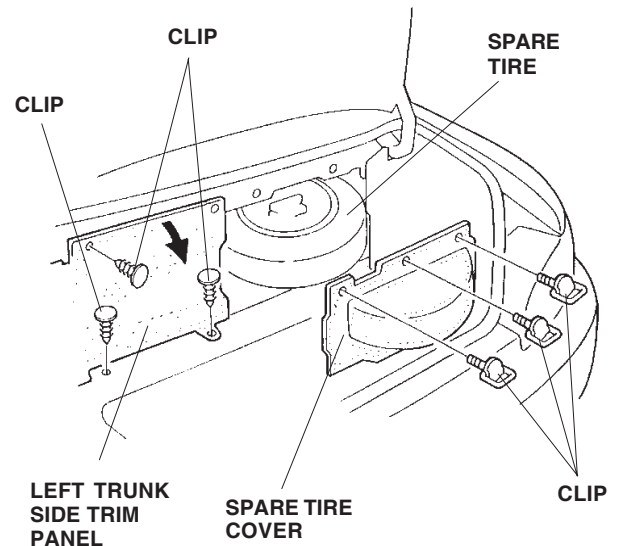

- Have an assistant hold the trunk lid open. While wearing heavy gloves to protect your hands, remove the old trunk springs from the trunk hinge arms using the special tool. To prevent injury, pull the tool slowly and carefully toward you.

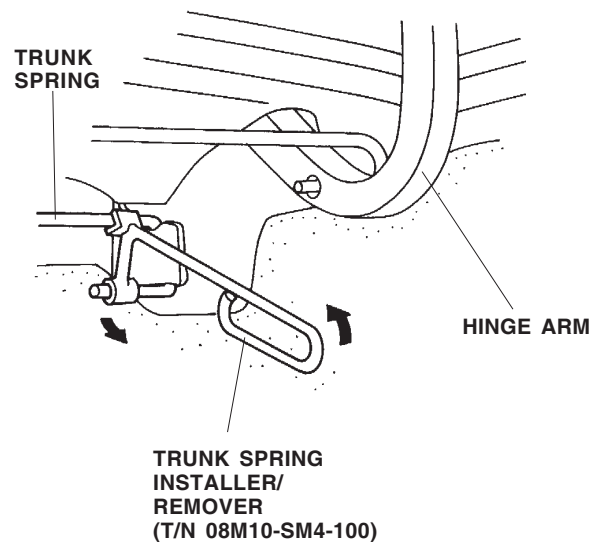

16. Install the heavy-duty springs in the reverse order of removal:

- Set the tool on the unmarked end of each trunk spring.
- While wearing heavy gloves, rotate the tool as you pull it toward you.
- Set the trunk springs in the original notch of the hinge arms.

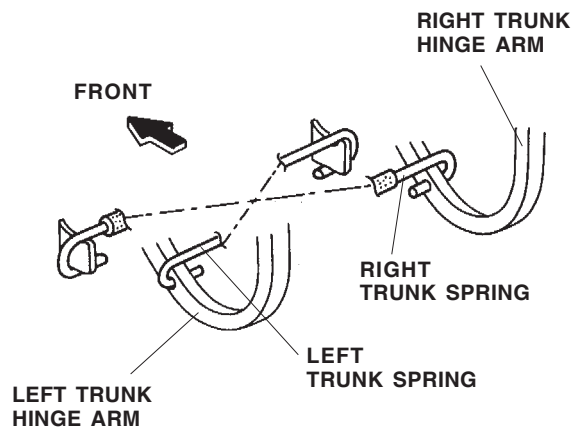

Use and Care of the Spoiler

- Handle the spoiler with care; it is not designed to absorb impact.
- Check the spoiler mounting nuts and bolts periodically, and retighten them if necessary.