



INSTALLATION INSTRUCTIONS

Accessory

FRONT LOWER TRIM
P/N 08P01-SJC-110

Application

2006 RIDGELINE

Publications No.

All 28605

Issue Date

FEB 2005

PARTS LIST

Front lower trim

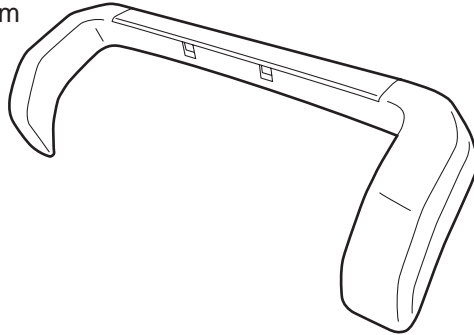

10 Screws



10 Washers



TOOLS AND SUPPLIES REQUIRED

Phillips screwdriver

Flat-tip screwdriver

Ratchet

10 mm Socket

Blanket

Drill

3 mm and 10 mm bits

Center punch

INSTALLATION

Customer Information: The information in this installation instruction is intended for use only by skilled technicians who have the proper tools, equipment, and training to correctly and safely add equipment to your vehicle. These procedures should not be attempted by "do-it-yourselfers."

NOTE:

- Be careful not to damage the body finish.
- If you are also installing a bumper trim, install the bumper trim before installing the front lower trim.

1. Open the hood, then remove the front bumper (seven clips, four bolts, two short step bolts and two self-tapping screws). Place the front bumper on a blanket.

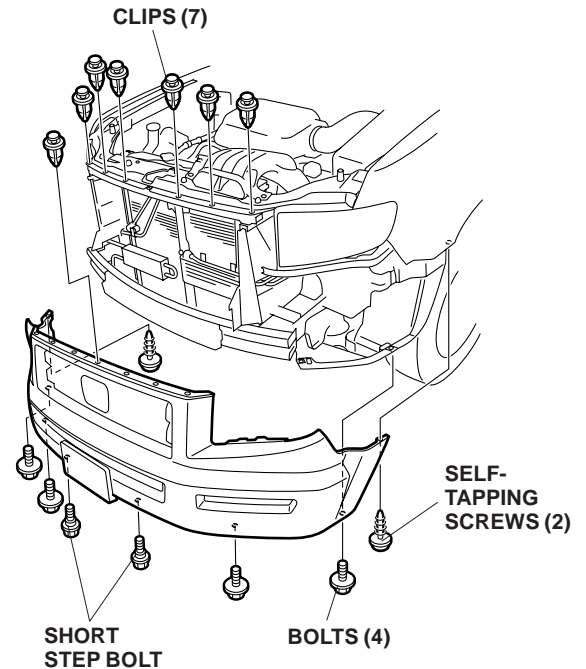

2. Locate the ten front lower trim marks, and center punch the ten marked locations. While wearing eye protection, drill a 10 mm hole through the ten marked locations. First drill with a 3 mm drill bit, and then finish with a 10 mm drill bit. Remove all burrs from the edges of the holes with a file.

Do not confuse the front lower trim marks with the front bumper trim marks when making the holes.

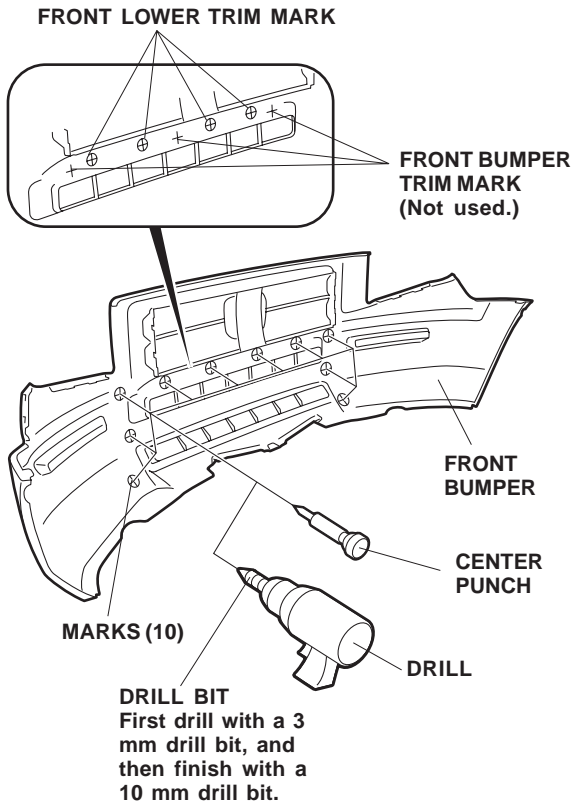

3. Position the front lower trim on the front bumper, and install the ten screws and ten washers. Tighten the screws securely.

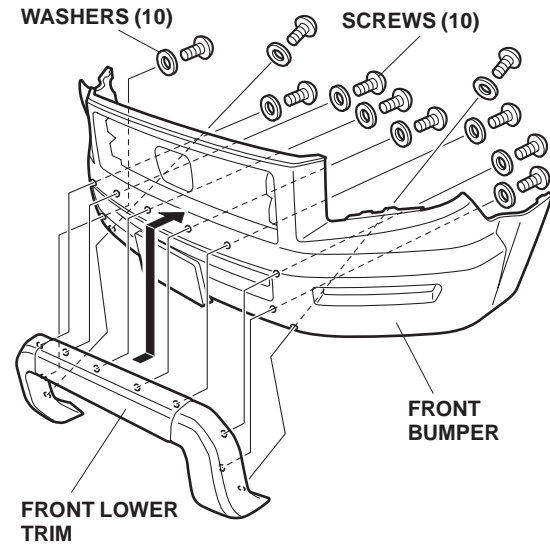

4. Reinstall the front bumper. Check that all retaining tabs and clips are installed properly without play or rattle.