



INSTALLATION INSTRUCTIONS

Accessory	Application	Publications No.
XM RADIO SYSTEM	2006 CIVIC 4 DOOR (EX)	All 30852
		Issue Date JAN 2006

PARTS LIST

**XM Radio Attachment (sold separately):
P/N 08B15-SNA-100A**

BUS cable

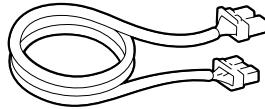

Bracket A

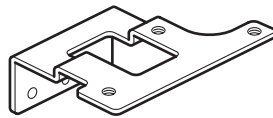

Bracket B

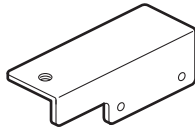

Clip



Double-face tape

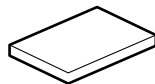

5 Pan-screws, 5 x 8 mm



5 Plain-washers, 5 mm



3 Flange-bolts, 6 x 12 mm



Coupler clip



Cover seal

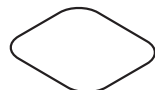

20 Wire ties

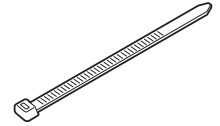

7 Wire tie with clips

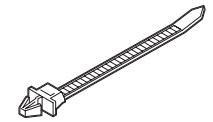

12 Cushion tapes

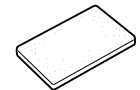

8 EPT seals



**XM Antenna (sold separately):
P/N: 08A15-EX5-100B**

Antenna Assy

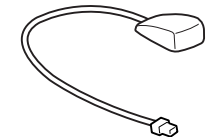

Splitter Assy

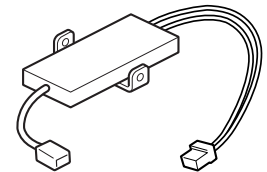

Coupler clip



Unit kit (sold separately):
P/N 08A15-EX5-000

XM tuner

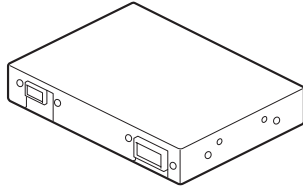

Bus Cable 2 Port (sold separately):
P/N 08A31-0F1-000

BUS cable 2 Port

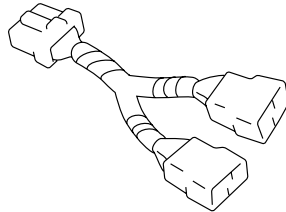

TOOL AND SUPPLIES REQUIRED

- #2 Phillips screwdriver
- Flat-tip screwdriver
- Utility knife
- Diagonal cutters
- Tape measure
- Shop towel
- Scissors
- Ratchet
- 8 mm, 10 mm and 14 mm Socket
- 8 mm, 10 mm and 14 mm Combination wrenches
- Isopropyl alcohol
- (Isopropyl alcohol, in a 60/40 solution with water)
- Rubber hammer
- Masking tape

Illustration of the XM Radio System Installed on the vehicle

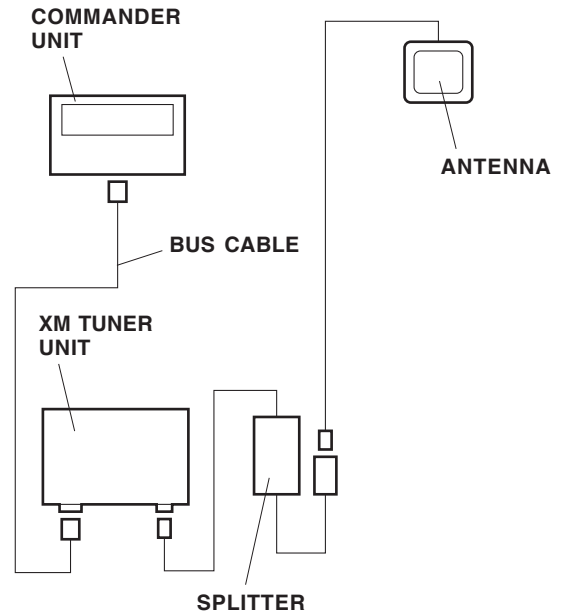
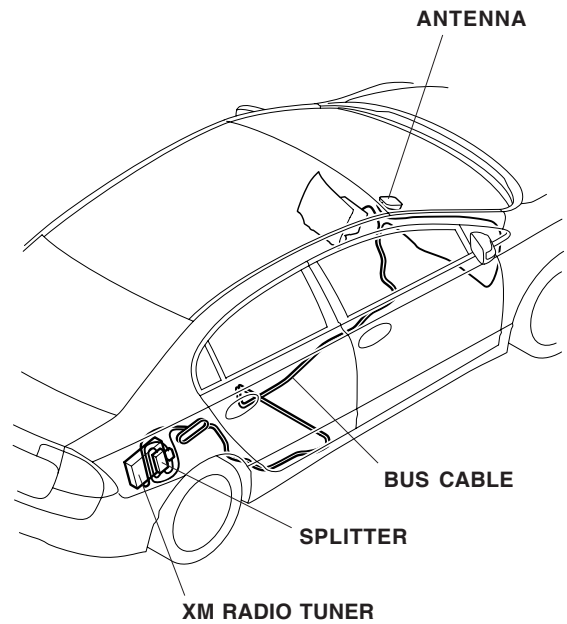

INSTALLATION

Customer Information: The information in this installation instruction is intended for use only by skilled technicians who have the proper tools, equipment, and training to correctly and safely add equipment to your vehicle. These procedures should not be attempted by “do-it-yourselfers.”

1. Make sure you have the anti-theft code for the radio, then write down the frequencies for the preset buttons.
2. Disconnect the negative cable from the battery.
3. Remove the passenger's dashboard lower cover (four clips, and two pins).

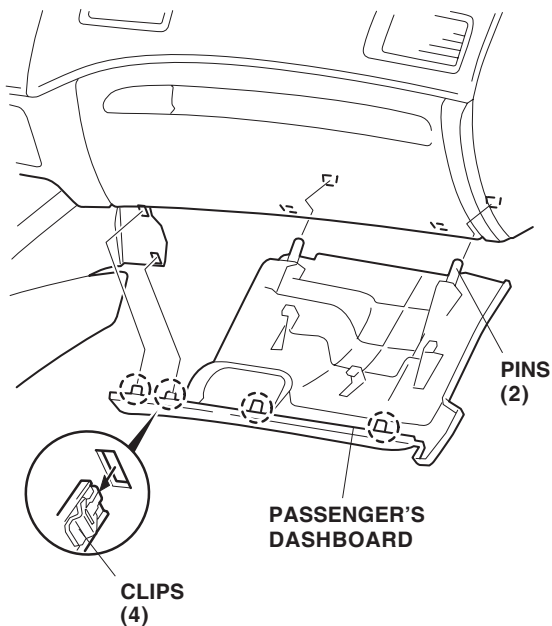

4. Remove the two bolts under the glove box.
5. Open the globe box. Release the stoppers and remove the globe box.

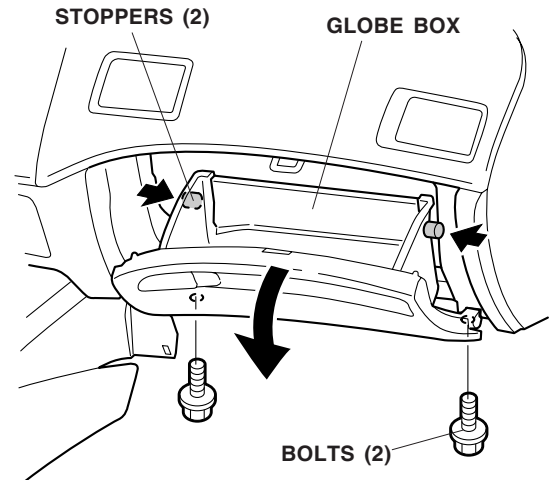

6. Remove the driver's dashboard lower cover (eight clips).

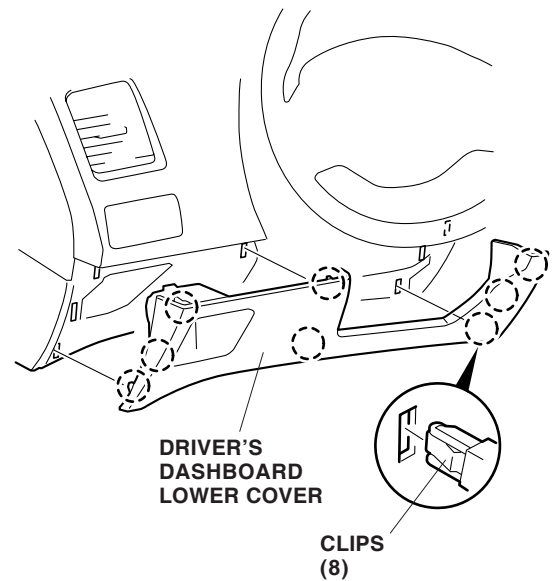

- Remove the inside cover from the front console pocket (two tabs).

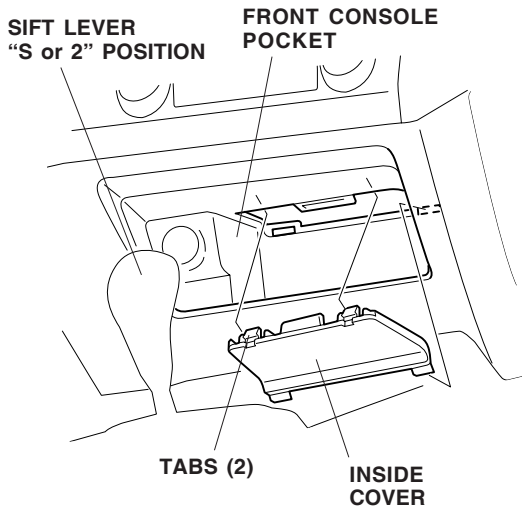

- Lower the steering wheel lever and pull the steering toward you.

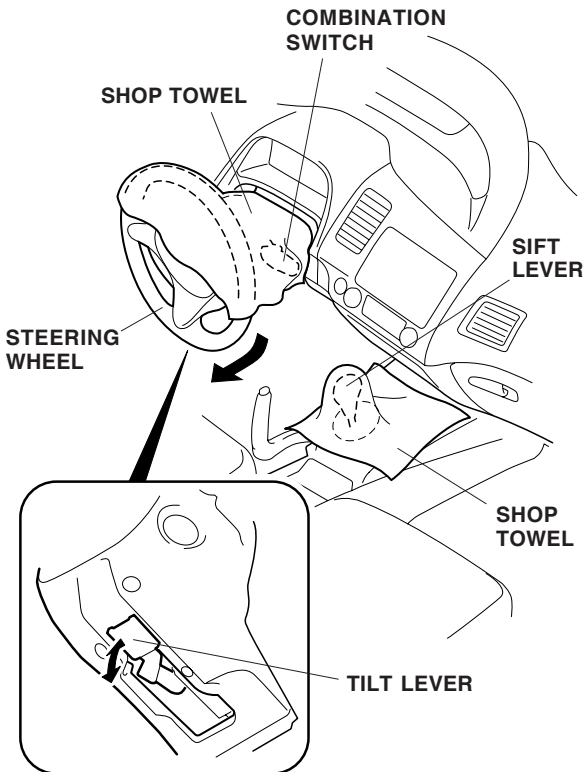

- To protect the dashboard area, place a shop towel over the steering wheel and shift lever.

- Apply masking tape to the meter panel as shown, and remove the instrument panel (one self-tapping screws, 11 clips, and one connector).

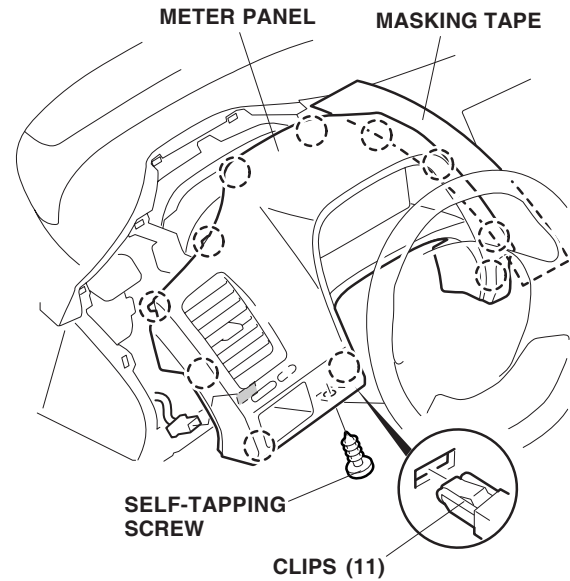

- Apply masking tape to the instrument panel as shown, and remove the center panel (two bolts, ten retaining clips, and unplug the vehicle connectors).

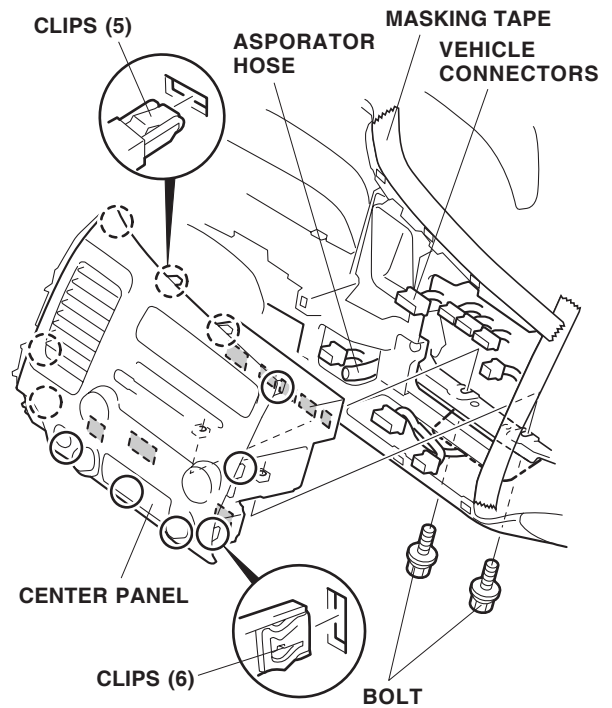

12. Remove the weatherstrip from the opening edge of the right front door in the area shown.
13. Push the clip into the vehicle side by striking the top of the right front pillar trim in the part marked as "SIDE CURTAIN AIRBAG" with the rubber mallet perpendicularly to the vehicle. Then, remove the clip.

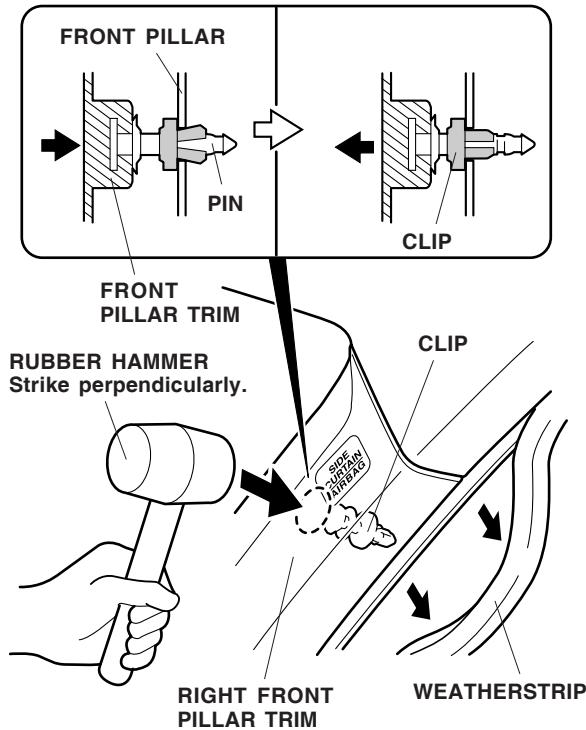

14. Remove the weatherstrip in the area shown. And remove the right front pillar trim (two clips).

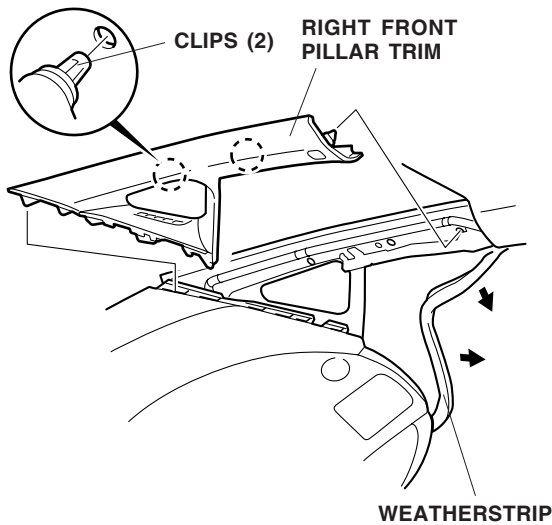

15. Remove the cap from the right sunvisor (four retaining tabs).
16. Remove the right sunvisor (two T25 Torx screws, and unplug the vehicle connectors).
17. Remove the right and left sunvisor holders. Turn the holders 90°, then pull it out.

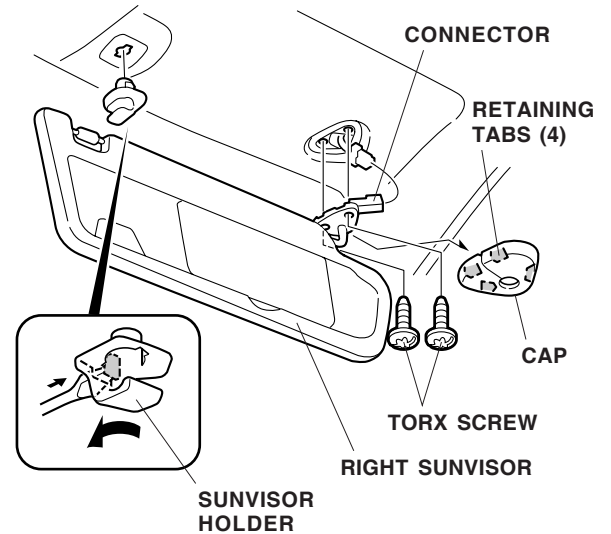

18. Remove the center console cover.

A/T Vehicle

- Remove the center console cover (five clips).

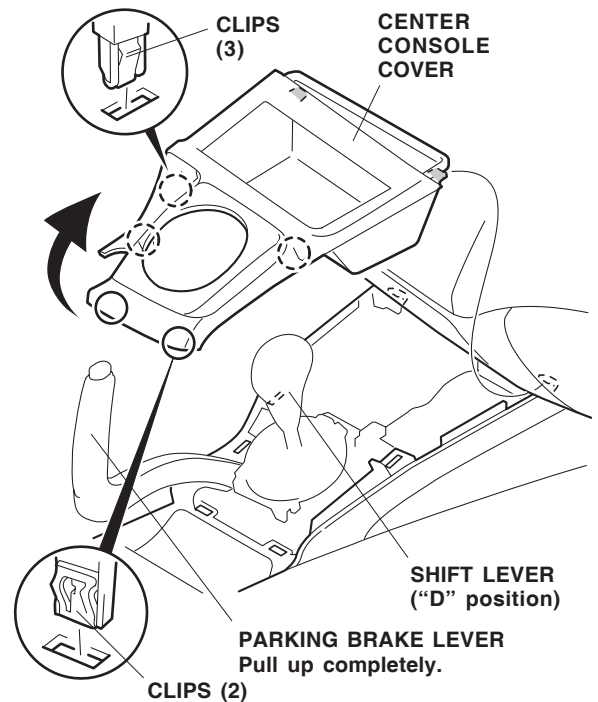

M/T Vehicle

- Pull down on the shift boot. Remove the shift knob by turning it counterclockwise.

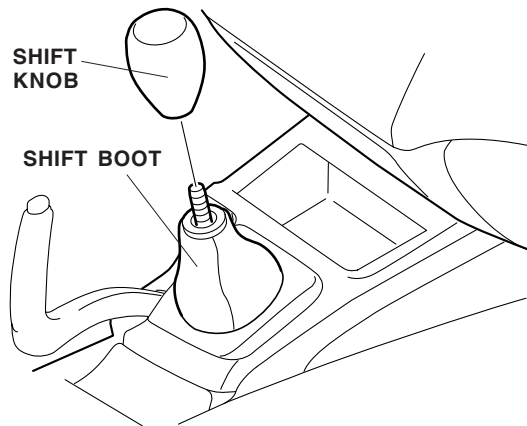

- Remove the center console cover by removing the five clips fastening the center console cover.

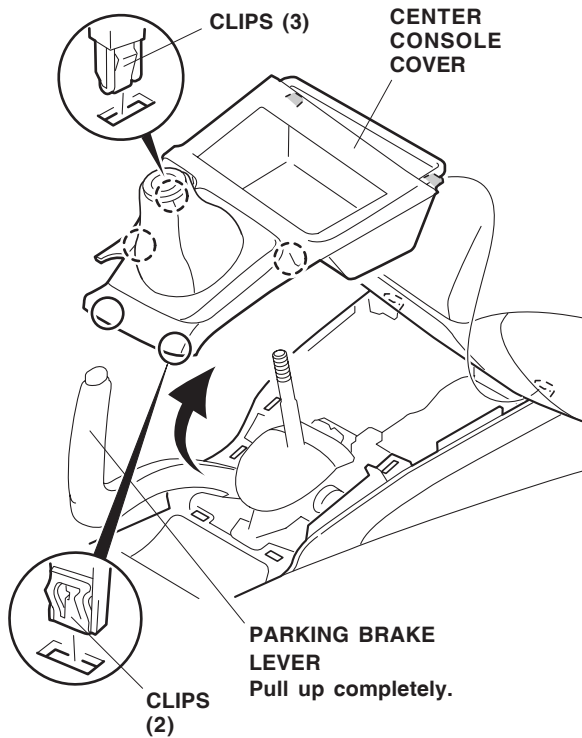

19. Open the center console lid, and remove the mat.

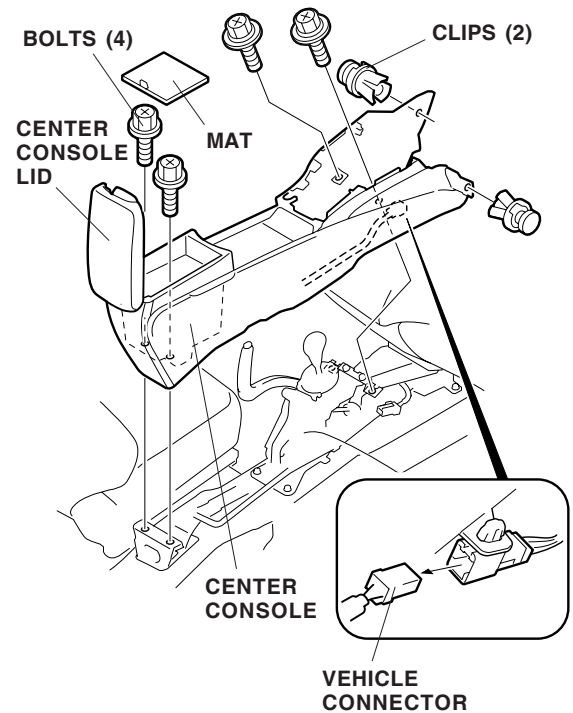

20. Remove the center console (four bolts, two clips, and the vehicle connector).
21. Remove the rear seat cushion (one bolt and release the two hooks).

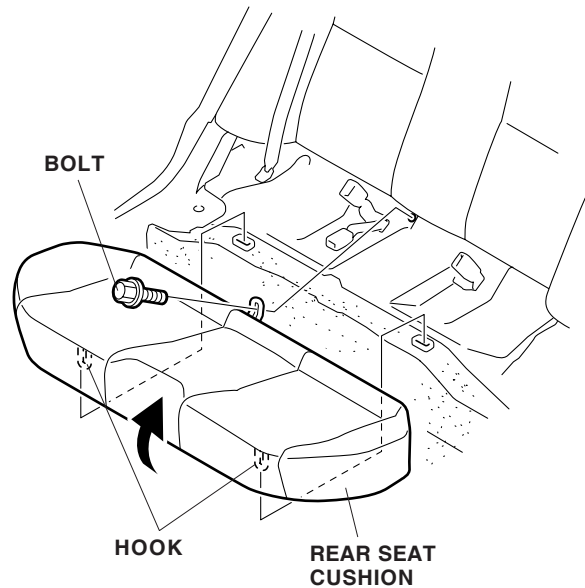

22. Remove the right seat side bolster (one bolt).

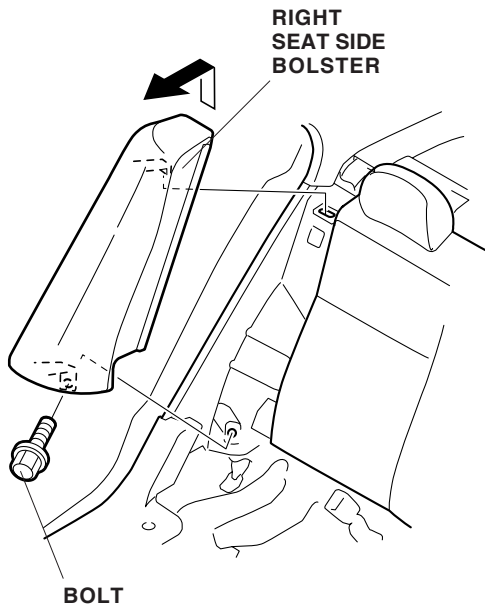

23. Remove the right rear side step trim (four clips and three retaining tabs).

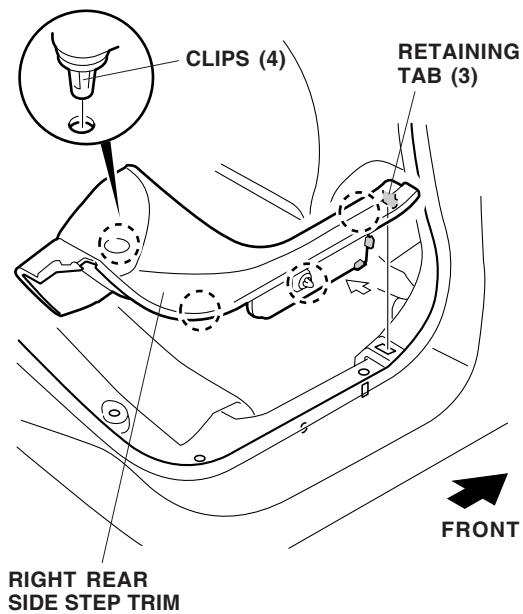

24. Open the trunk lid, fold the rear seatback forward by pulling the levers under the rear parcel shelf. Remove the trunk floor mat (two clips).

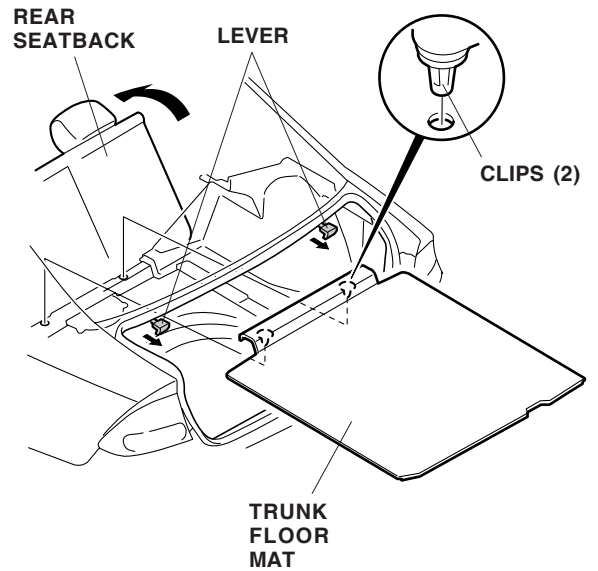

25. Remove the trunk weatherstrip from the edge of the trunk opening in the area shown.

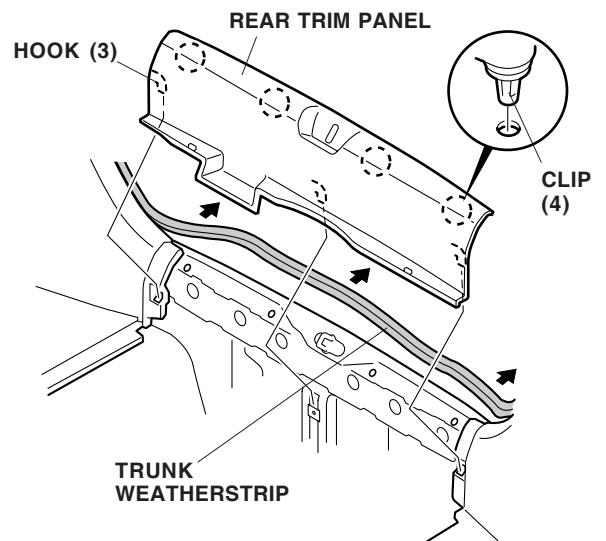

26. Remove the rear trim panel (four clips and three hooks).
27. Continue removing the weatherstrip in the area shown. Remove the five clips, then pull out on the right trunk side trim panel in the direction shown.

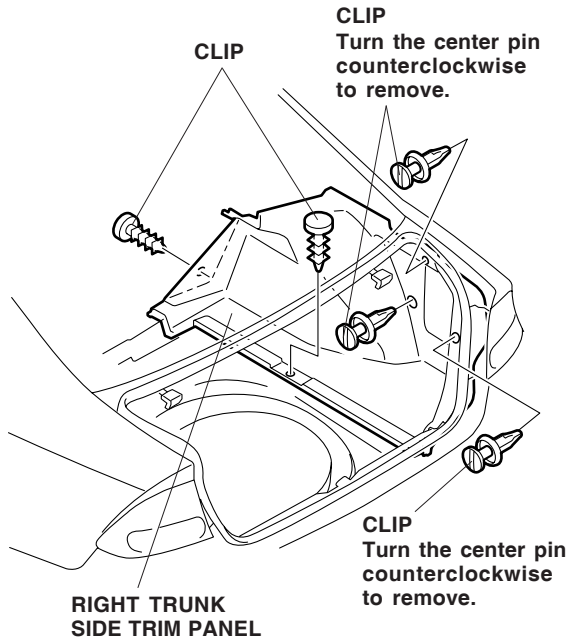

Routing the BUS Cable

28. Route the BUS cable from the trunk along the vehicle harness.

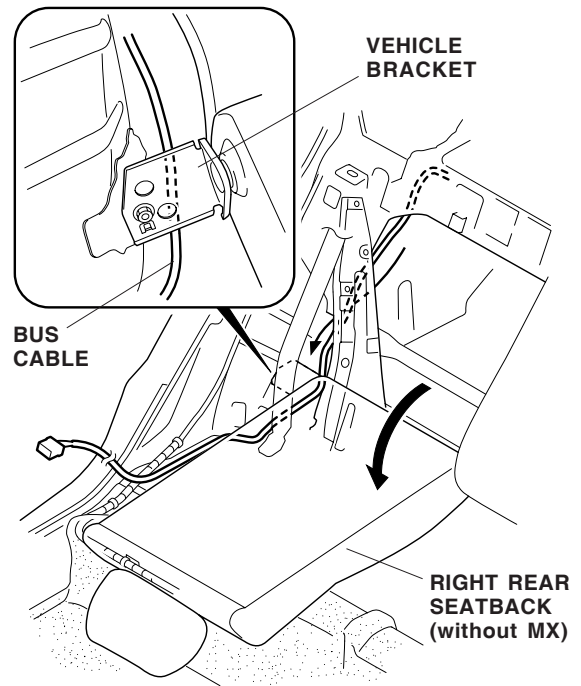

29. Lift up and lock the right rear seatback, then remove the clip that secures the floor carpet. Pull back the floor carpet.

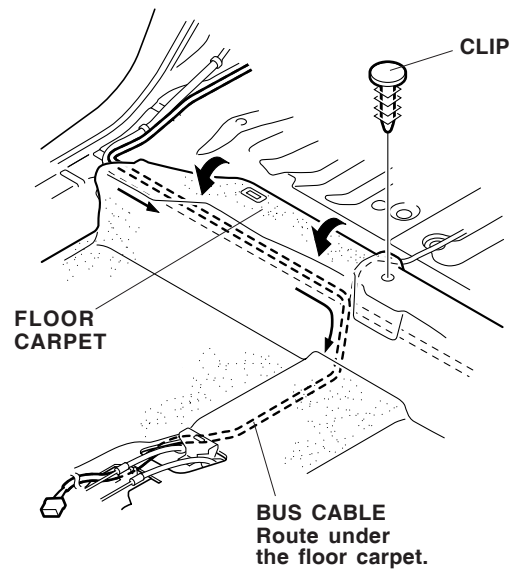

30. Route the BUS cable forward under the floor carpet.

31. Route the BUS cable forward to the right front console frame along the vehicle harness.

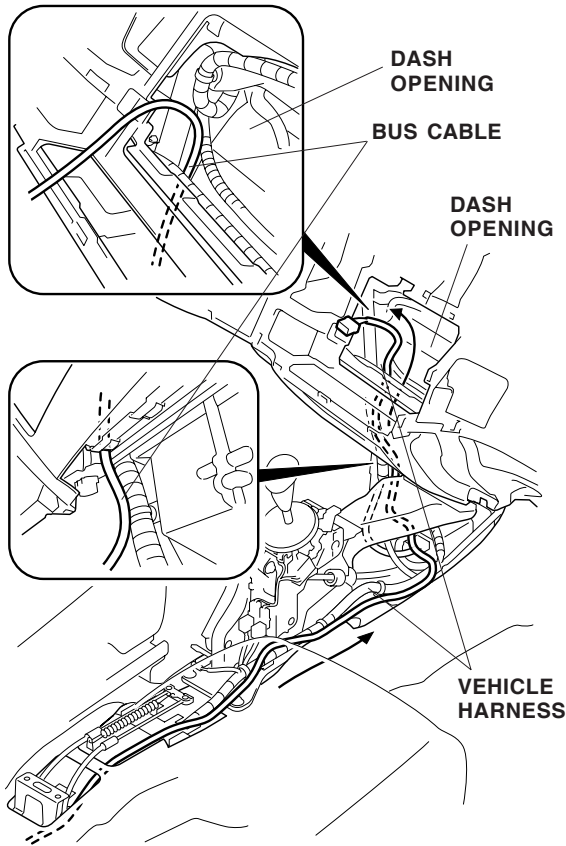

32. Route the BUS cable connector to the dashboard and out through the dash opening.

Routing the antenna cable

33. Using isopropyl alcohol on a shop towel, clean the antenna where the doubleside tape will attach. Remove an adhesive backing from the doubleside tape, and attach it to the antenna.

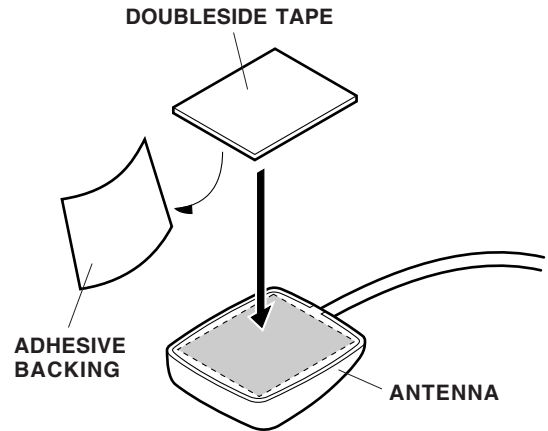

34. Using isopropyl alcohol on a shop towel, clean the right front upper corner on the inside of the front window.
35. Remove the adhesive backing from the antenna, and attach the antenna to the front window at the location shown. Install the antenna by applying sufficient pressure.

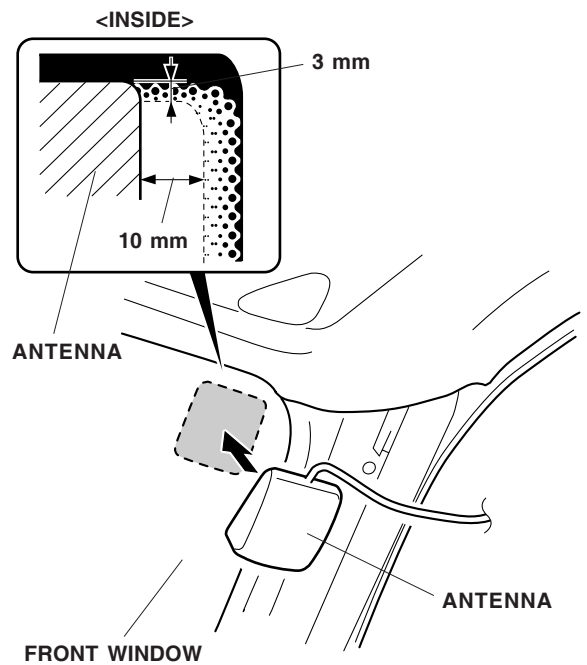

36. Using isopropyl alcohol on a shop towel, clean the right front upper corner on the outside of the front window.

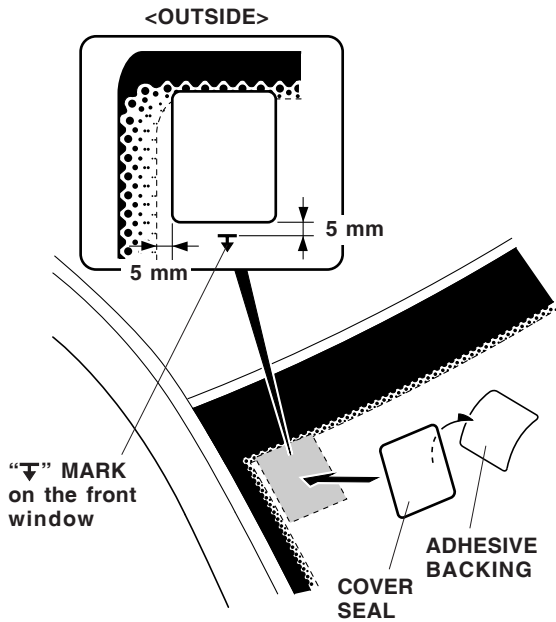

37. Remove the adhesive backing from the cover seal, and attach it to the out side of the front window at the location shown.
38. Using scissors, cut three EPT sealers in half.

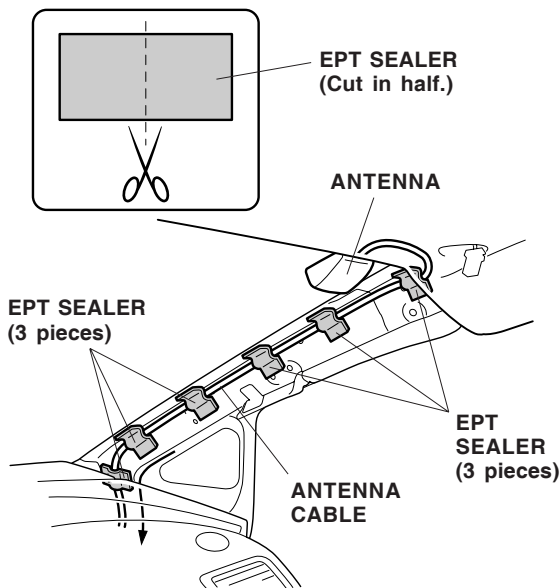

39. Route the antenna cable down the passenger's A-pillar. Attach the antenna cable to the A-pillar panel with the six pieces of cut EPT sealer in areas shown.

40. Route the antenna cable down behind the dashboard stay and towards the glove box. Secure the antenna cable to the vehicle harness with the three wire ties.

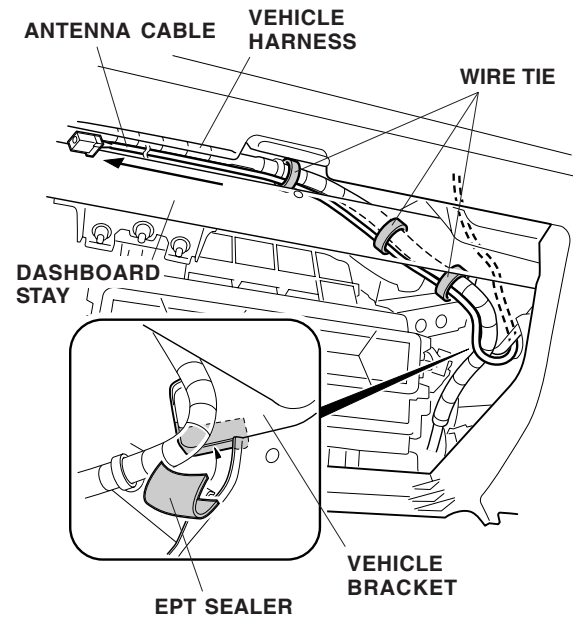

41. Inside the glove box opening, route the antenna cable along the vehicle harness and towards the audio unit opening. Secure the antenna cable to the vehicle harness with the wire tie in areas shown.

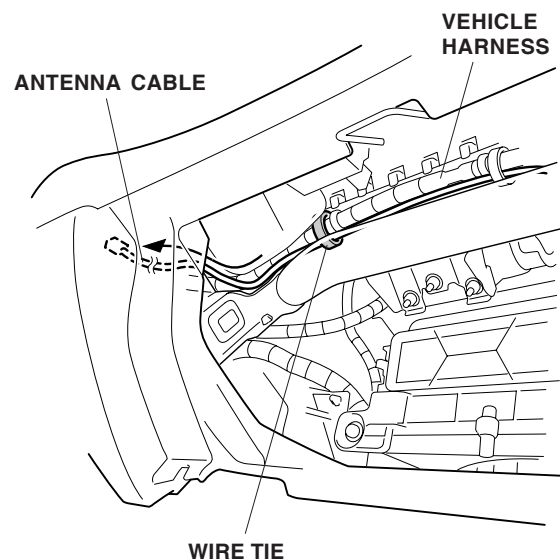

42. Route the antenna cable down along the BUS cable as shown.
43. Measure 300 mm from the end of the BUS cable connector, then secure the BUS cable and antenna cable to the vehicle harness with six wire ties.

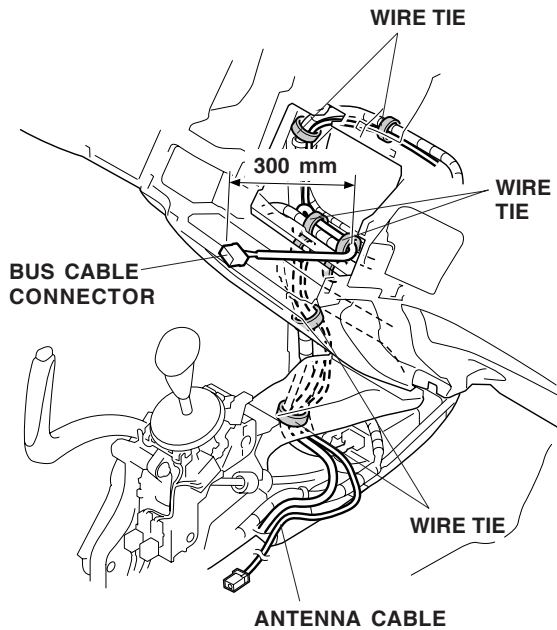

44. Route the antenna cable along the BUS cable, secure the BUS cable and antenna cable to the vehicle harness with three wire ties.
45. Using isopropyl alcohol on a shop towel, clean the area where the cushion tape will attach. Attach the BUS cable and antenna cable to the floor panel with the two cushion tapes in the area shown.

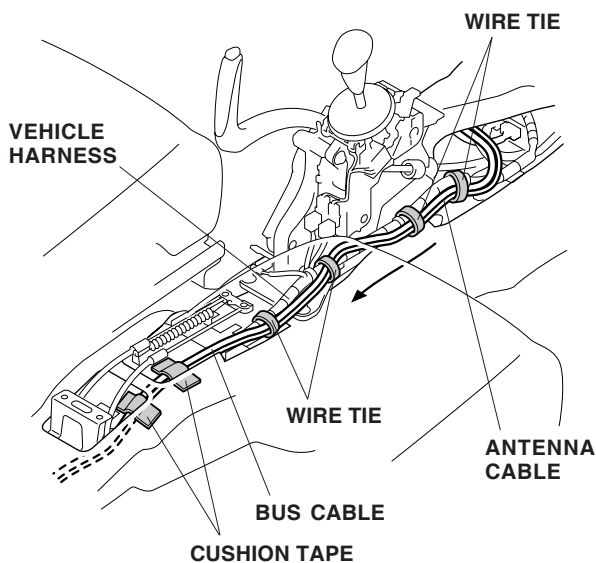

46. Route the antenna cable along the BUS cable, turn over the floor carpet, then attach the BUS cable and antenna cable to the floor panel with the two cushion tapes in the areas shown.
47. Secure the BUS cable and antenna cable to the vehicle harness with the three wire ties in the areas shown.

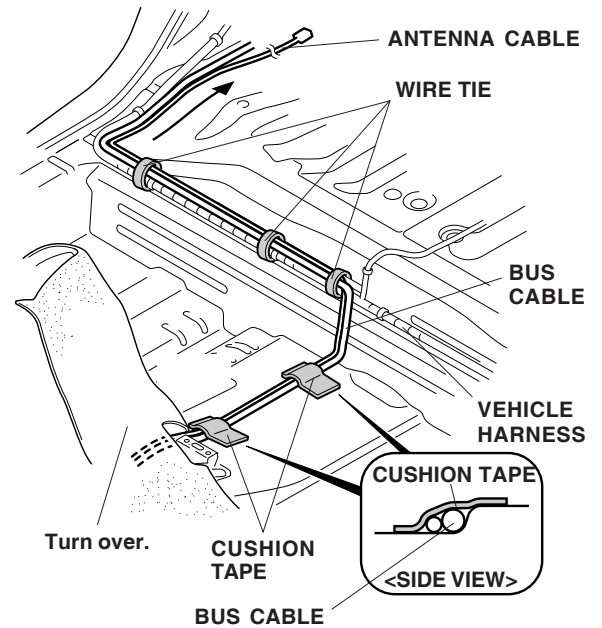

48. Route the antenna cable along the BUS cable, secure the BUS cable and antenna cable to the vehicle harness with the two wire ties in the areas shown.
49. Attach the BUS cable and antenna cable to the floor panel with the four cushion tapes in the areas shown.

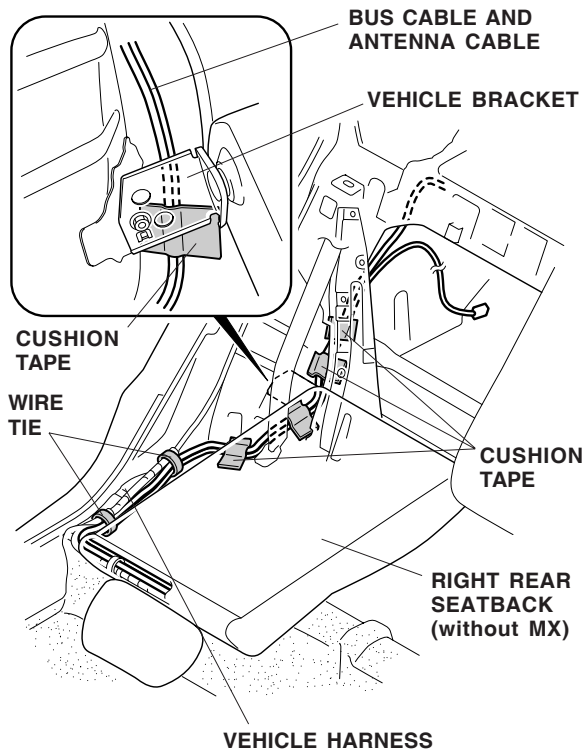

50. Route the BUS cable and the antenna cable up on the right trunk inner panel. Loosely secure them to the holes of the panel with the three wire ties with clip.

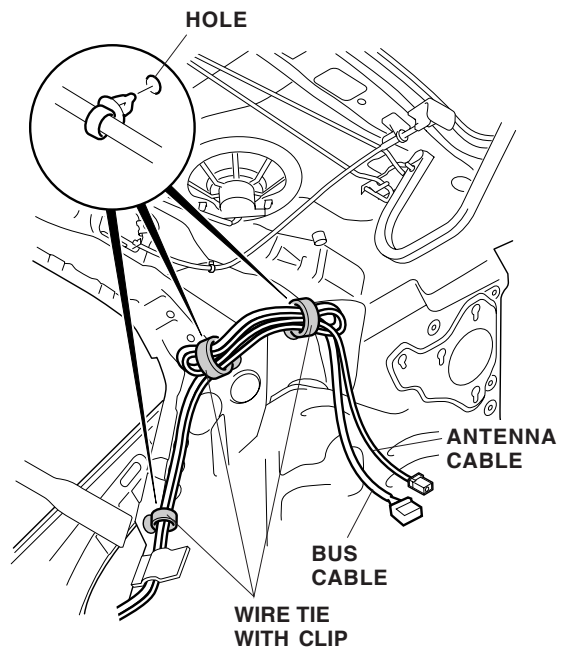

Installing the XM Tuner unit

51. Install the bracket A and B to the XM tuner with four 5 x 8 mm washer-screws.

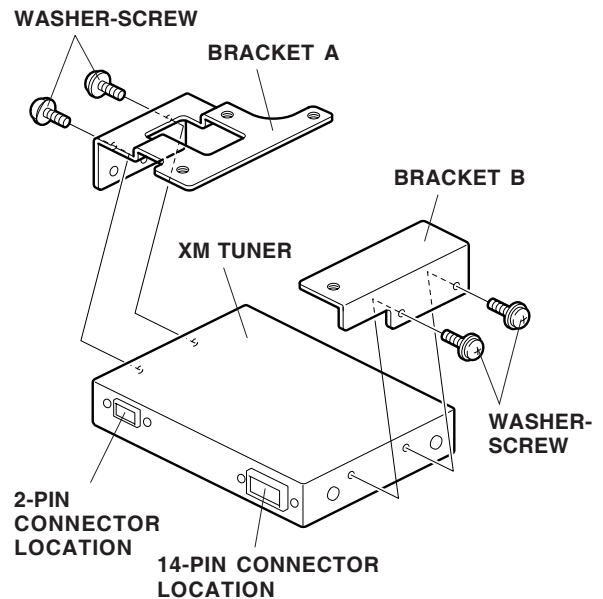

52. Using isopropyl alcohol on a shop towel, clean the XM tuner where the splitter will attach. Remove the adhesive backings from the double-face tape, and install the splitter to the XM tuner with the double-side tape at the location shown. Secure the splitter to the bracket A with one 5 x 8 mm washer-screw.

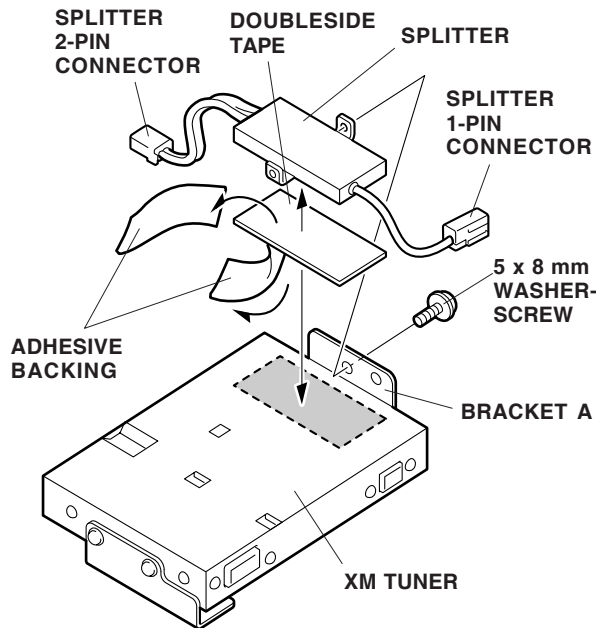

53. Plug the splitter 2-pin connector into the XM tuner.
 54. Install the connector clip to the splitter 1-pin connector, and then Insert it into the bracket A hole in the area shown.

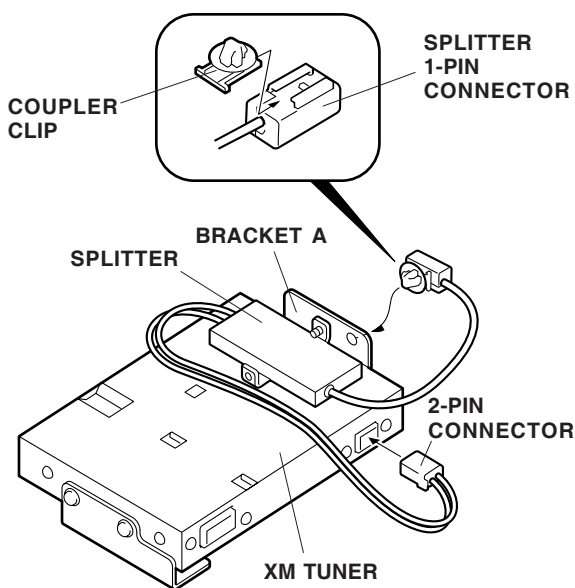

55. Using isopropyl alcohol on a shop towel, clean the right trunk inner panel where the EPT sealer will attach. And attach it to the right trunk inner panel at the location shown.

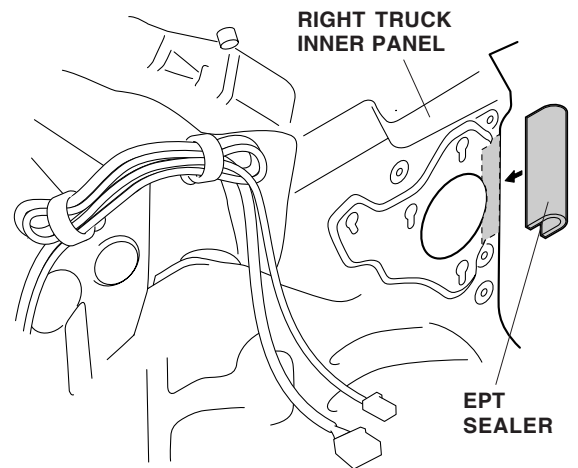

56. Route the BUS cable and the antenna cable through the hole of the right trunk inner panel.
 57. Plug the Bus cable connector into the XM tuner and the antenna cable connector to the splitter 1-pin connector.

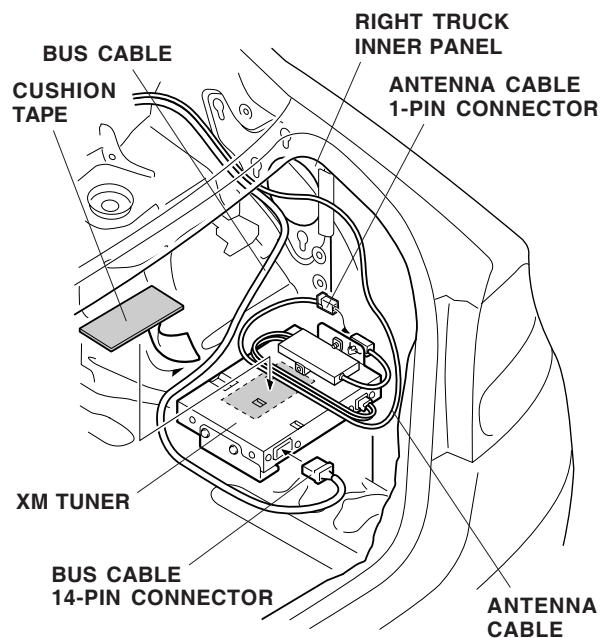

58. Attach the antenna cable on the XM tuner with the cushion tape in the area shown.

59. Loosely attach three 6 x 12 mm flange-bolts to the bracket A and B as shown.

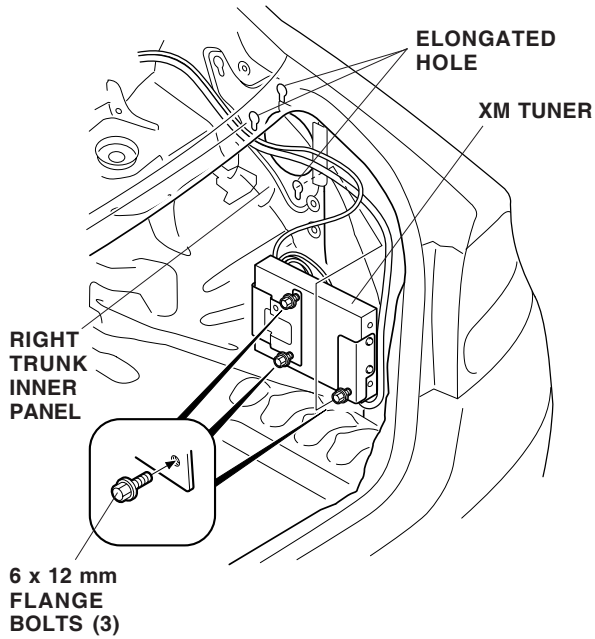

60. Place the XM radio assembly to back of the right trunk inner panel. Set the three 6 x 12 mm flange-bolts into the elongated holes in the body panel. Tighten the three 6 x 12 mm flange-bolts.

61. Fold the excess BUS cable and antenna cable and secure them with the two wire ties with clip installed in step 51.
62. Secure the BUS cable and the antenna cable to the holes on the right trunk inner panel with the three wire ties with clip.

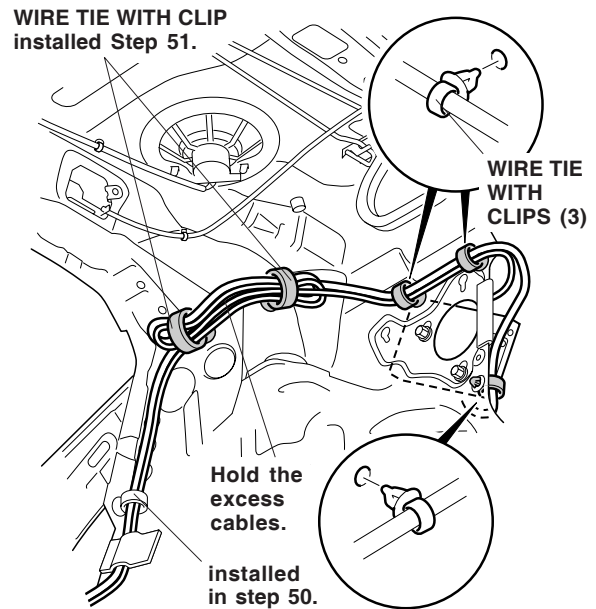

If the vehicle you're working on is equipped with CD Changer, go to step 63; otherwise, continue with step 65.

63. Plug in the BUS cable 2 port connectors the two BUS cables respectively.

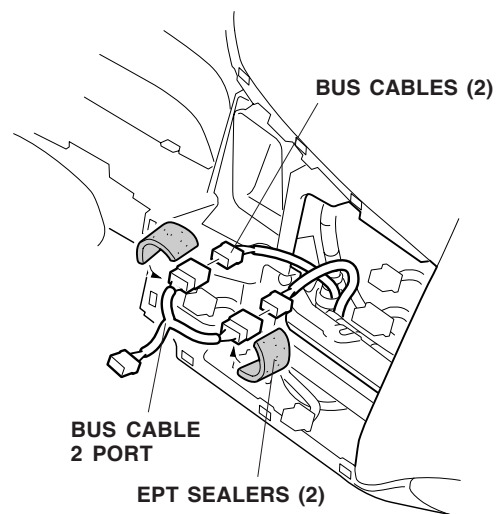

64. Wrap the two plugged connectors with the two EPT sealers respectively.

65. Plug the BUS cable connector into the rear of the audio unit.

<Standard Audio Unit>

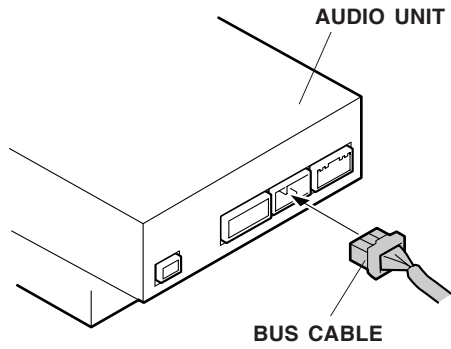

<Navigation System Unit>

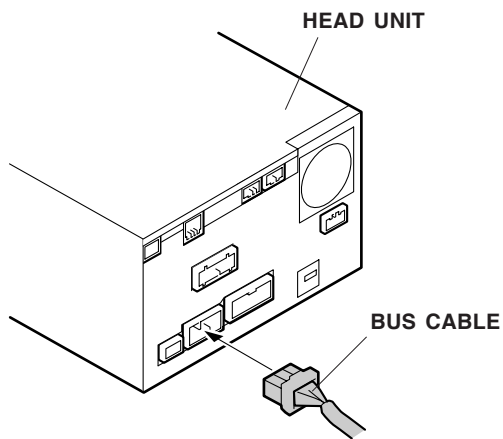

66. Connect the vehicle connectors to the center panel, and reinstall the center panel.

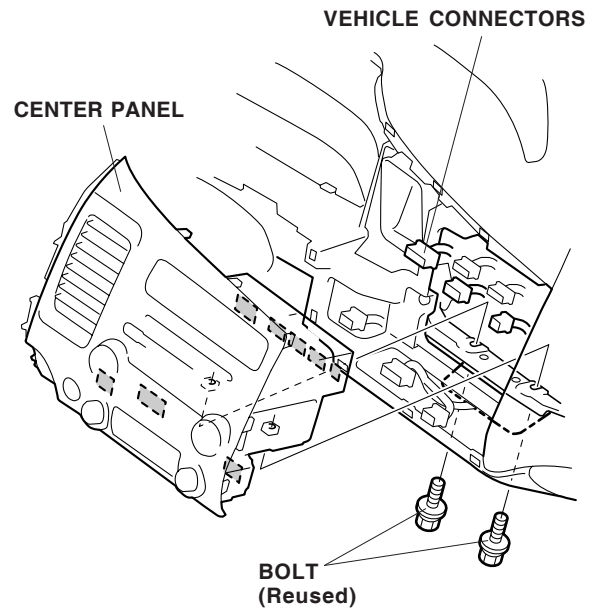

67. Exchange the old clip to a new one on the right front pillar trim.

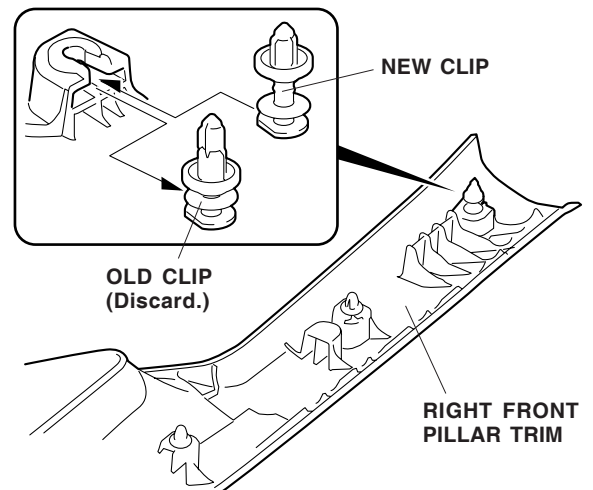

68. Check that all wire harnesses are routed properly and all connectors are plugged in.
69. Reconnect the negative cable to the battery.
70. Enter the customer's radio anti-theft code, and reset the radio station presets.
71. Set the clock.
72. Check the operation of the XM radio system according to the vehicle's Owner's Manual supplied.
73. Reinstall all removed parts.

NOTE: When the battery is disconnected, the driver's window AUTO function is disabled.

- Start the engine. Push down on the driver's window switch until the window is fully open.
- Pull up on the driver's window switch to close the window completely, then hold the switch for 2 seconds or more.
- Lower and raise the driver's window to check operation of the driver's window AUTO function.