



INSTALLATION INSTRUCTIONS

Accessory
**CASSETTE/MP3/
IN-DASH CD PLAYER
ATTACHMENT**

Application
**2006 ACCORD
2- AND 4-DOOR**

Publications No.
All 30664
Issue Date
AUG 2005

PARTS LIST

**Attachment Kit (sold separately):
P/N 08B06-SDA-101A**

Left player bracket



Right player bracket



Left player subbracket

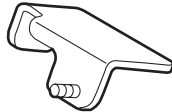

Right player subbracket

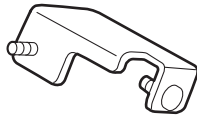

Player base-bracket
(With YAW sensor)

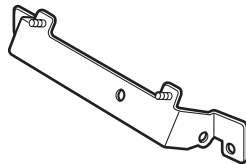

Player base-bracket
(Without YAW sensor)

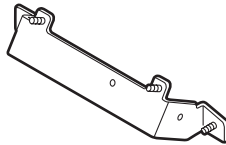

Player panel

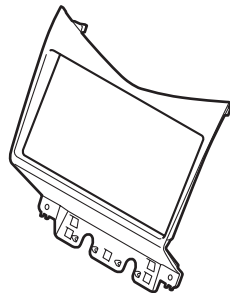

Pocket

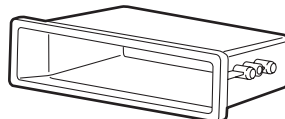

BUS cable

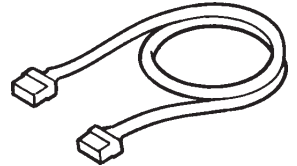

2 Latches



8 Flange nuts, 6 mm



2 Grommet screws



6 Wire ties

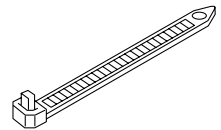

7 EPT sealers

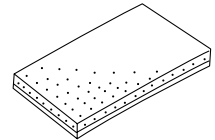

2 Self-tapping screws, 4 x 12 mm



2 Washer-bolts, 6 x 16 mm



**Bus Cable 2 Port (sold separately):
P/N 08A31-0F1-000**

BUS cable 2 Port
(for XM radio equipped vehicles)

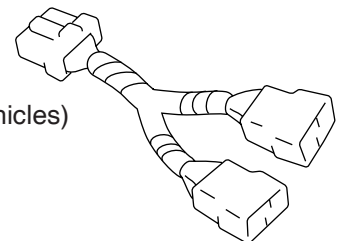

Cassette Player (sold separately):
P/N 08A03-5E1-000

Cassette player

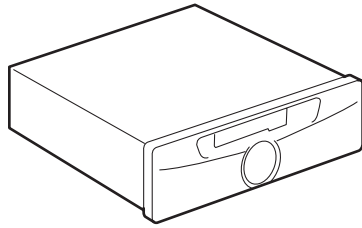

4 Washer-screws, 5 x 8 mm

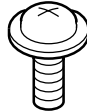

Owner's Manual

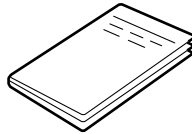

MP3 Player (sold separately):
P/N 08A06-4E1-200

Multi media player

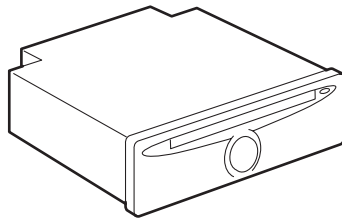

4 Washer-screws, 5 x 8 mm



Owner's Manual

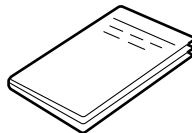

In-Dash CD Changer (sold separately):
P/N 08A06-3E1-300

In-dash CD changer

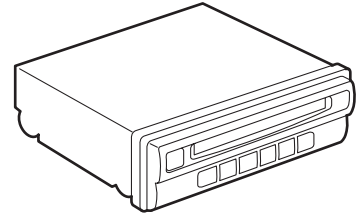

6 Washer-screws, 5 x 8 mm



Washer-screw, 4 x 6 mm



Wire tie

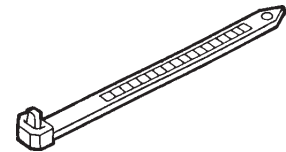

Harness clip

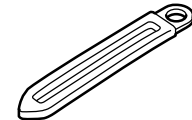

Owner's Manual

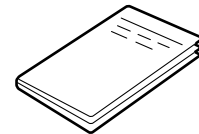

Seat

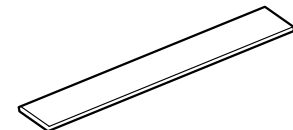

TOOLS AND SUPPLIES REQUIRED

Phillips screwdriver
Flat-tip screwdriver
10 mm Combination wrench
Ratchet
10 mm Socket
File
Utility knife
Scissors
Shop towel
Hook tool
Masking tape
Tape measure
Isopropyl alcohol
Diagonal cutters

INSTALLATION

Customer Information: The information in this installation instruction is intended for use only by skilled technicians who have the proper tools, equipment, and training to correctly and safely add equipment to your vehicle. These procedures should not be attempted by “do-it-yourselfers.”

1. Make sure you have the anti-theft code for the radio, then write down the frequencies for the preset buttons.
2. Disconnect the negative cable from the battery.
3. Remove the trim ring.

M/T Model:

- *Without locknut:* Squeeze the plastic clip and pull down on the shift boot. Remove the shift knob by turning it counterclockwise.

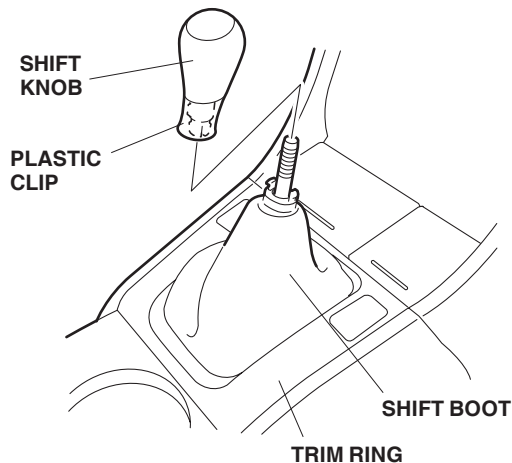

- *With locknut:* Loosen the lock nut and remove the gearshift knob.

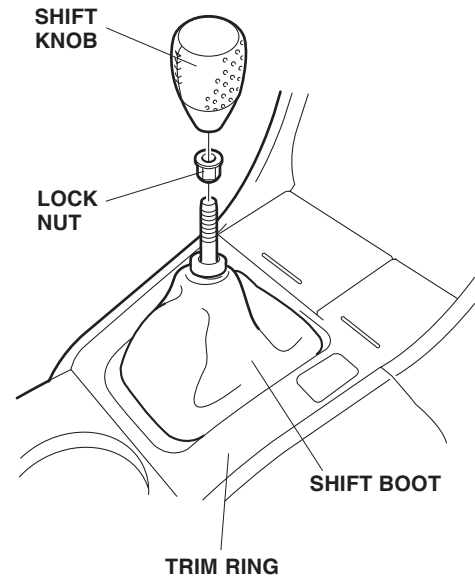

- Gently pry up on the trim ring to release the six clips.
- Unplug the two seat heater connectors (if equipped), and remove the trim ring.

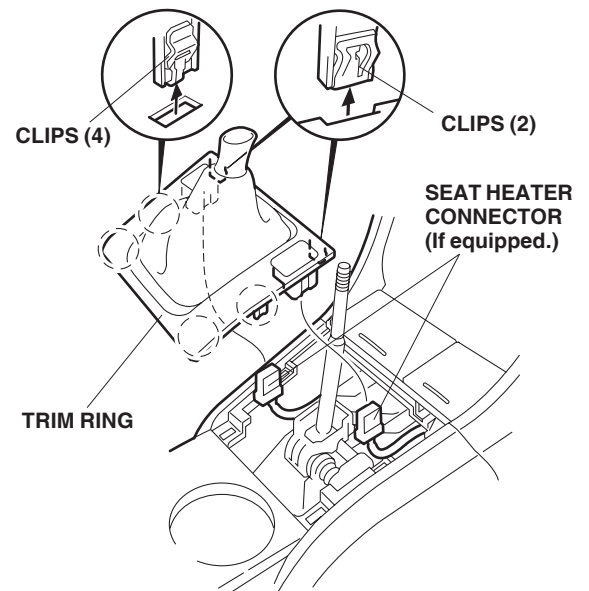

A/T Model:

- Insert the ignition key in the shift lock release hole, and move the shift lever to the "D" position while pressing down on the key.
- Gently pry up on the trim ring to release the six clips.
- Unplug the seat heater connectors (if equipped), and remove the trim ring.

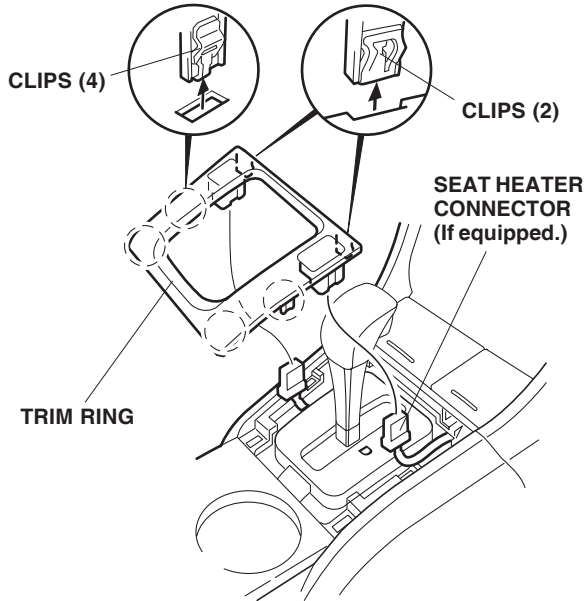

4. Remove the dashboard center holder:
- Open the coin pocket lid and remove the coin pocket.
 - Remove the two self-tapping screws.
 - Gently pull out on the dashboard center holder to release the three retaining tabs, unplug the vehicle connector, and remove the dashboard center holder.

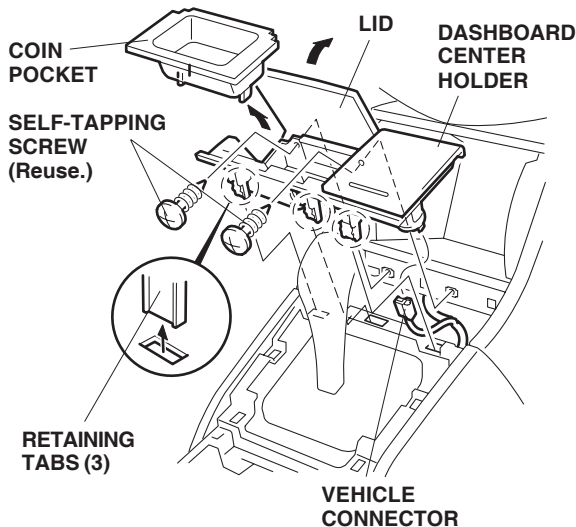

With Ashtray

- Open the lid and remove the ashtray.
- Remove the two self-tapping screws.
- Gently pull out on the two retaining clips, unplug the cigarette lighter harness connector, vehicle connector, illumination bulb, and remove the dashboard center holder.

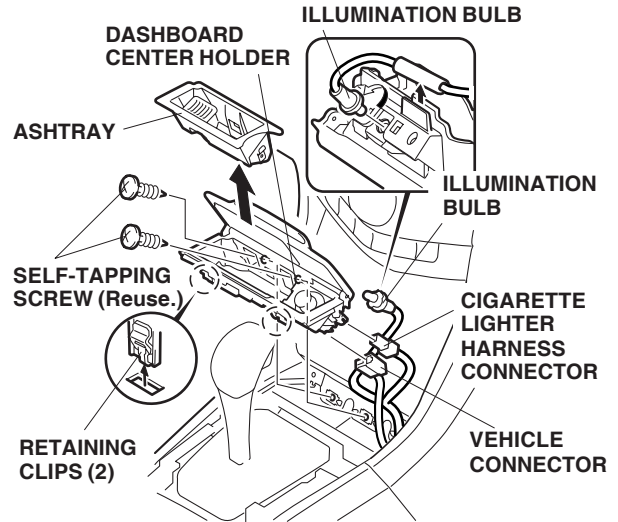

5. Remove the pocket:
- Apply masking tape to the bottom edge of the center panel.
 - Remove the two self-tapping screws.
 - Push in on the bottom of the pocket, then insert the end of a hook tool between the pocket and center panel, to pull out the top, and release the two retaining clips.

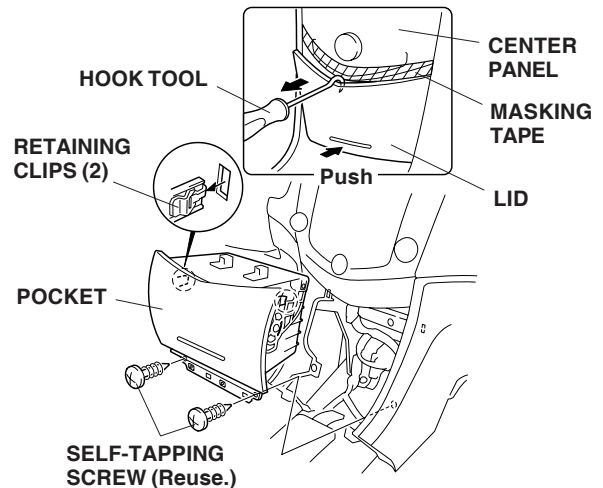

- Remove the right and left inner covers (one hook and one clip for each cover).

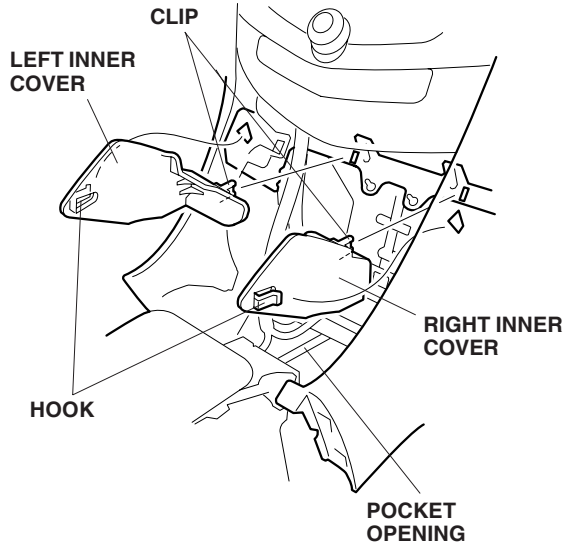

Installing the Player

If the vehicle is equipped with a YAW sensor, continue with step 7; otherwise, go to step 11.

- Remove the vehicle clip from the left side of the pocket opening as shown.

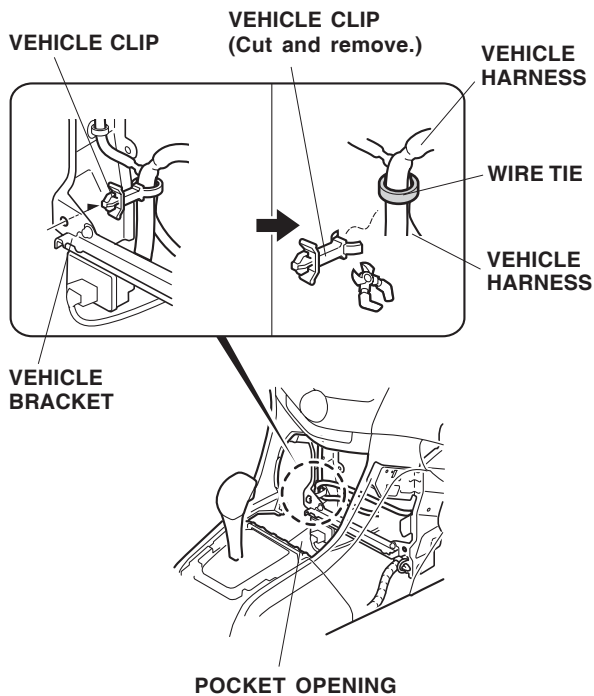

- Using diagonal cutters, cut and remove the vehicle clip. Secure the vehicle harness to the other vehicle harness using one wire tie. Take care not to damage the vehicle harness.

- Remove the vehicle clip from the right side of the pocket opening.

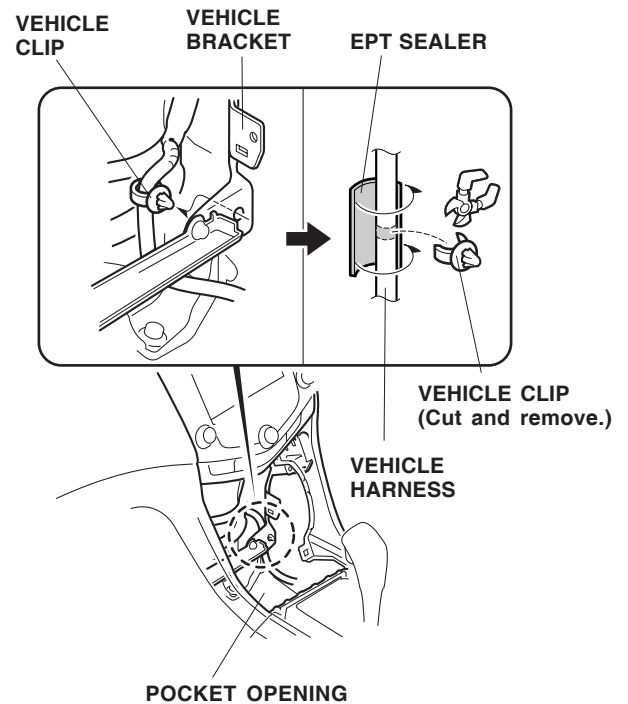

- Using diagonal cutters, cut and remove the vehicle clip. Wrap one EPT sealer onto the vehicle harness. Take care not to damage the vehicle harness.

- Install the player base bracket:
 - With YAW sensor: Install the player base-bracket to the vehicle frame, using two 6 x 16 mm washer bolts and two 6 mm flange nuts the bracket firmly against the vehicle frame.

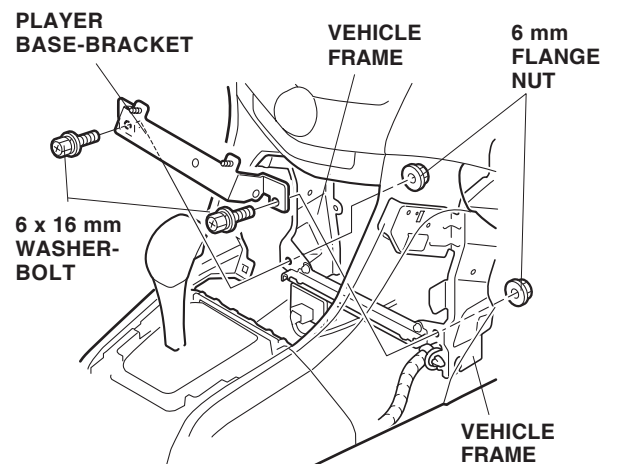

- *Without YAW sensor:* Install the player base-bracket to the vehicle frame, then install the two 6 mm flange nuts while holding the bracket firmly against the vehicle frame.

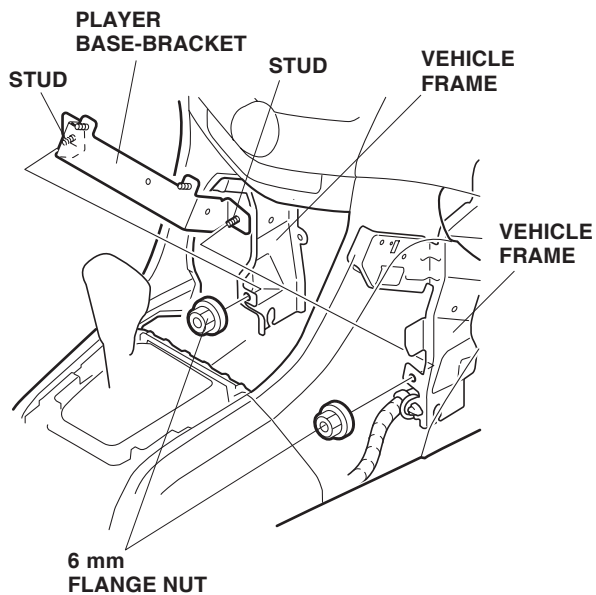

12. If you are installing an in-dash CD changer, remove the shipping bracket.

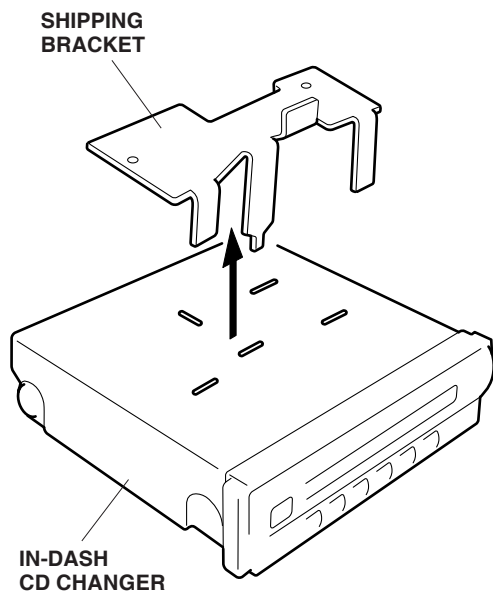

13. Get the pocket. Using a utility knife, cut the two lugs off from the pocket.

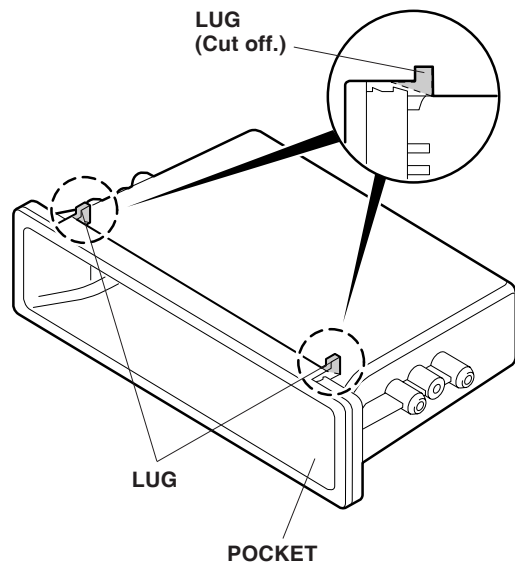

14. Install one latch to the left and right player brackets.

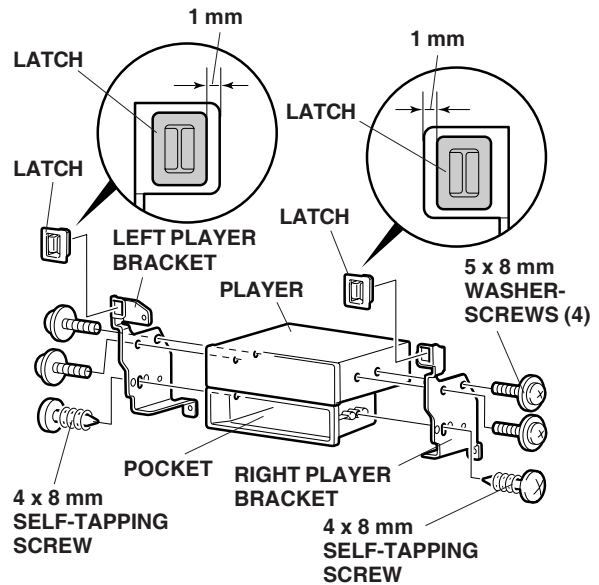

15. Position the left and right player brackets on the player and pocket, and install four 5 x 8 mm washer-screws from the player kit, and two 4 x 8 mm self-tapping screws from the attachment kit.

If the vehicle is equipped with an XM radio, continue with step 16; otherwise, go to step 31.

16. Pull out the plugged vehicle connector as shown. Unplug the vehicle connector, and plug in the bus cable 2 port connectors in between.
17. Wrap the one plugged connectors with the one EPT sealer.

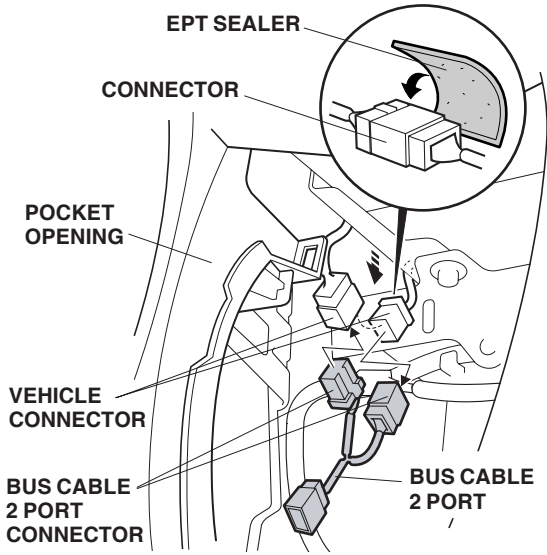

18. Insert the studs from the left and right player subbrackets into the holes in the vehicle frame, then install one 6 mm flange nut on the end of each stud while pushing each subbracket upward.

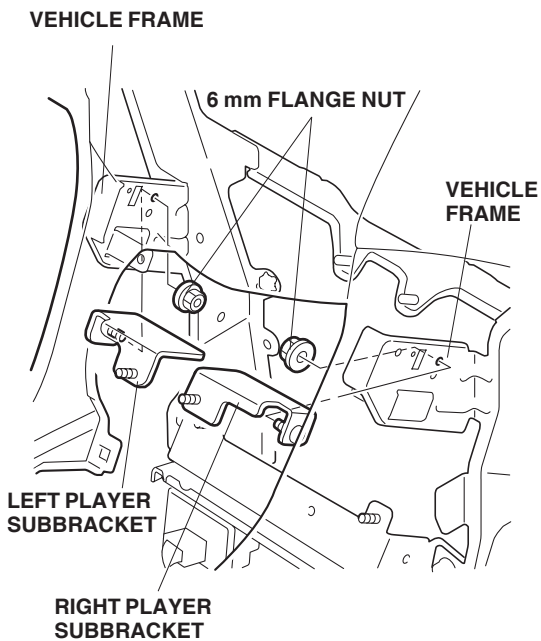

19. Plug the bus cable to the bus cable 2 port connector.

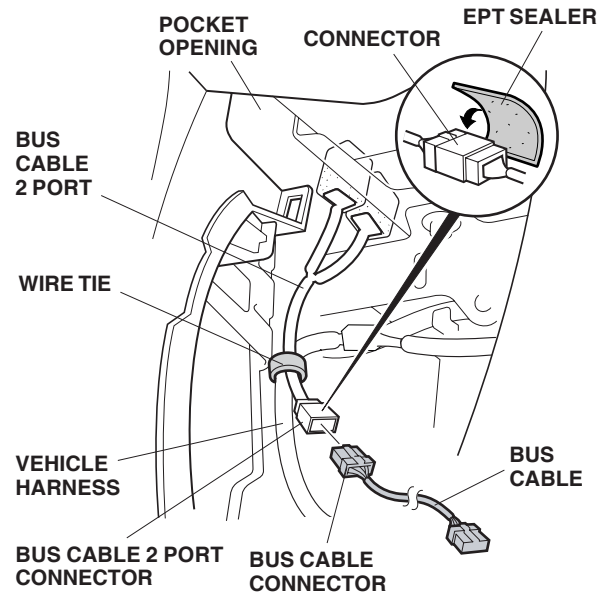

20. Secure the bus cable 2 port to the vehicle harness with the one wire tie.
21. Wrap the plugged connector with one EPT sealer.
22. Secure the bus cable to the vehicle harness with one wire tie so that the distance between the wire tie and the end of the bus cable connector is 200 mm.

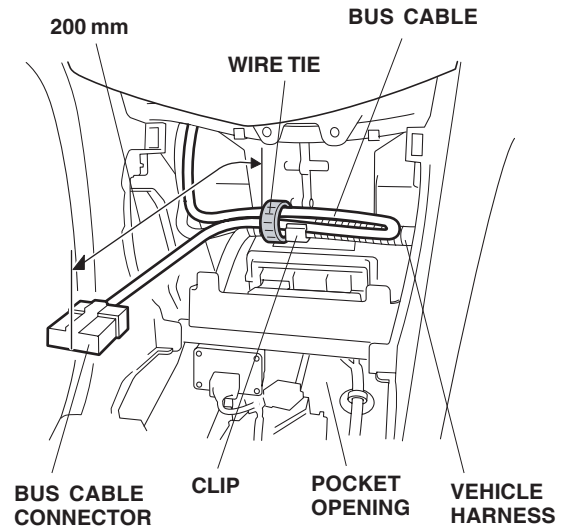

23. To protect the center panel, attach the masking tape to the panel in the area shown.

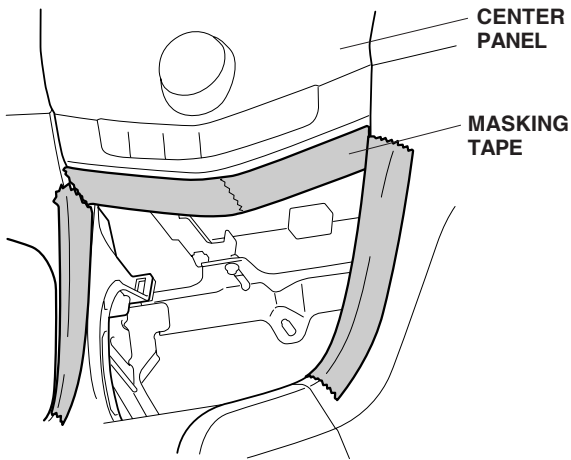

24. Plug the bus cable connector into the player connector. Insert the studs of the left and right player subbrackets and player base-bracket into the holes in the left and right player brackets, then install one 6 mm flange nut on the end of each stud.

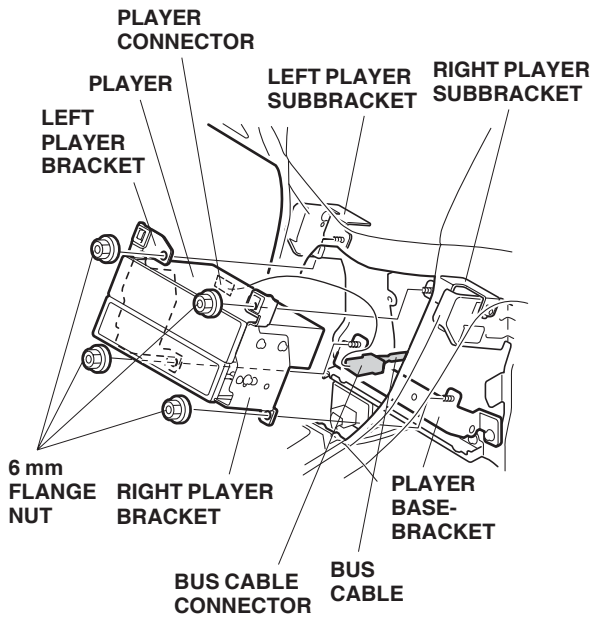

Cassette Player

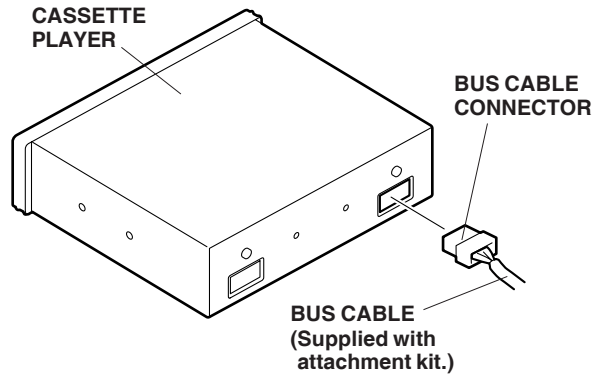

Multi-media Player

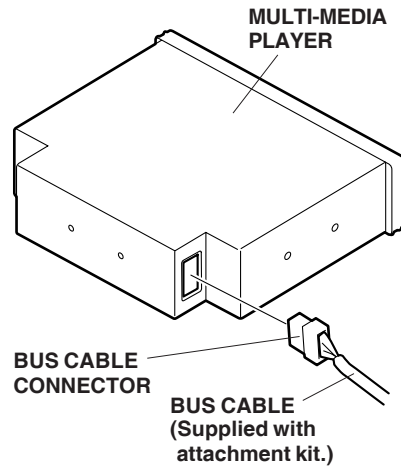

In-dash CD Changer

- After connecting, secure the connectors to the rear of the in-dash CD changer with one wire tie from in the in-dash CD changer kit.

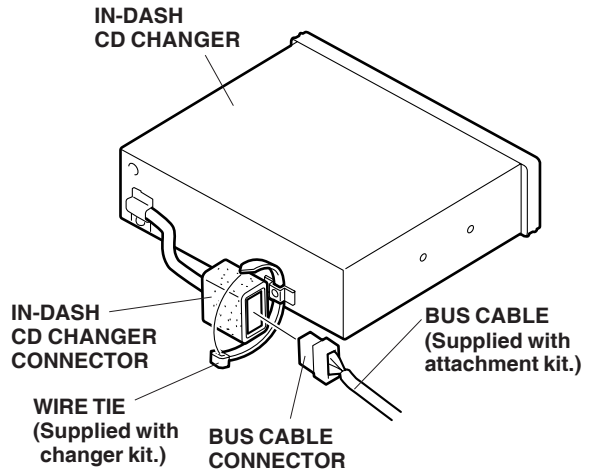

25. Attach two grommet screws to the player panel in the square holes shown.

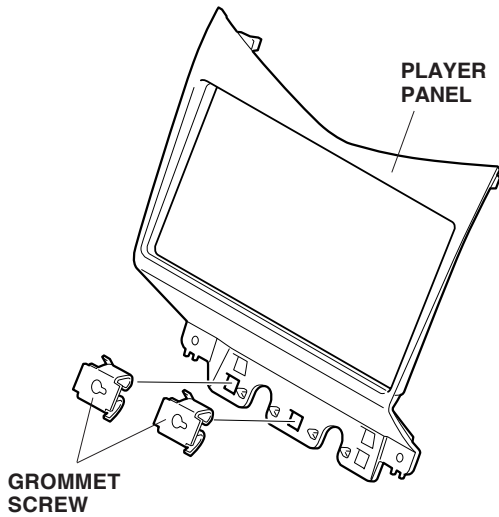

26. Using scissors, cut one EPT sealer into three pieces.
27. Using isopropyl alcohol on a clean towel, wipe the player panel where the EPT sealers will attach. Attach the EPT sealer to the player panel and cut off the excess.

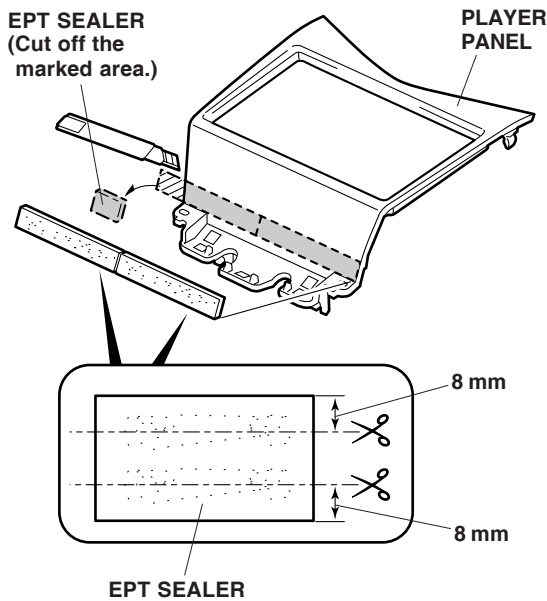

28. Remove the masking tape attached in step 23.

29. Insert the player panel clips into the latches, and attach the player panel to the instrument panel with the two self-tapping screws you removed in step 5.

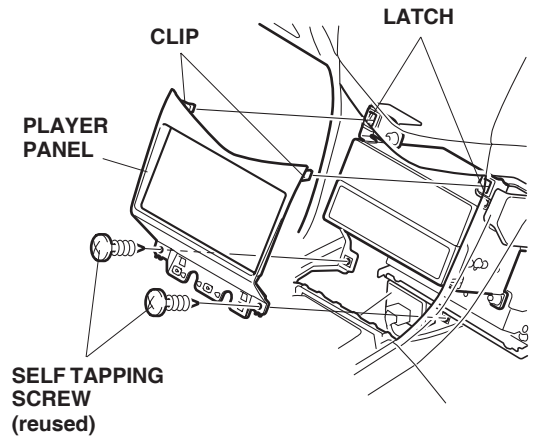

30. Go to step 39.
31. Plug the BUS cable into the player.

Cassette Player

- Loop the BUS cable and secure it with one wire tie, so that the distance between the ends of the cable connectors are 200 mm. Plug the BUS cable connector into the cassette player connector.

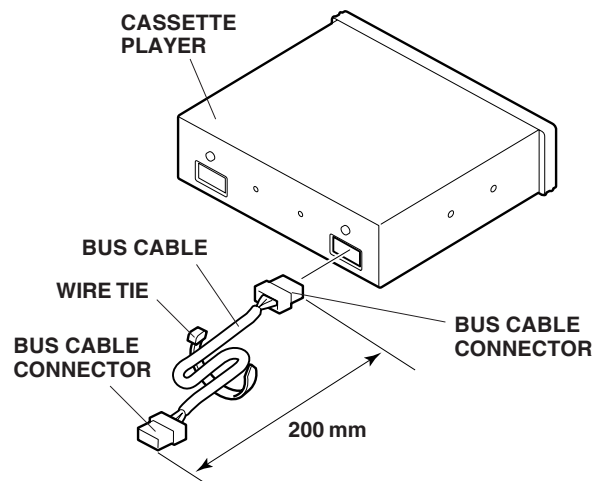

MP3 Player

- Loop the bus cable and secure it with one wire tie, so that the distance between the ends of the cable connectors are 200 mm. Plug the BUS cable connector into the multi media player connector.

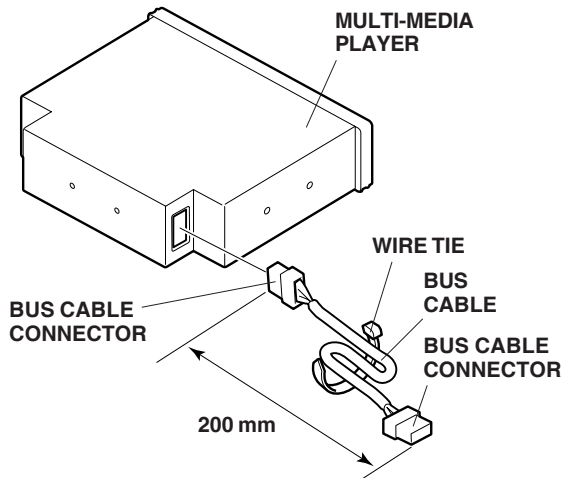

In-dash CD Changer

- Loop the bus cable and secure it with one wire tie, so that the distance between the ends of the cable connectors are 180 mm. Plug the bus cable connector into the connector from the in-dash CD changer.
- After connecting, secure the connectors to the rear of the in-dash CD changer with one wire tie from in the in-dash CD changer kit.

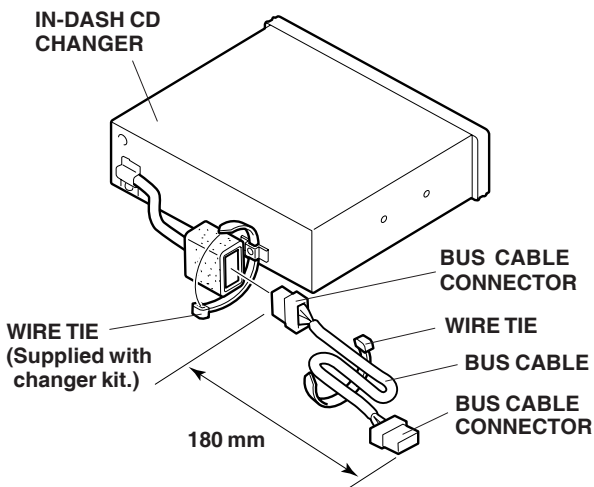

32. To protect the center panel, attach the masking tape to the panel in the area shown.

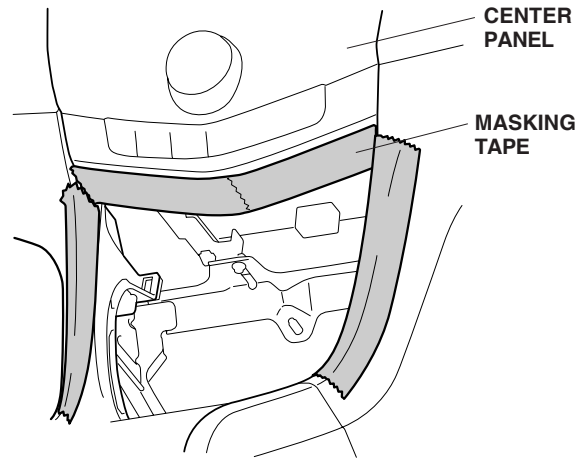

33. Plug the BUS cable connector into the vehicle connector. Insert the studs of the left and right player subbrackets and player base-bracket into the holes in the left and right player brackets, then install one 6 mm flange nut on the end of each stud.

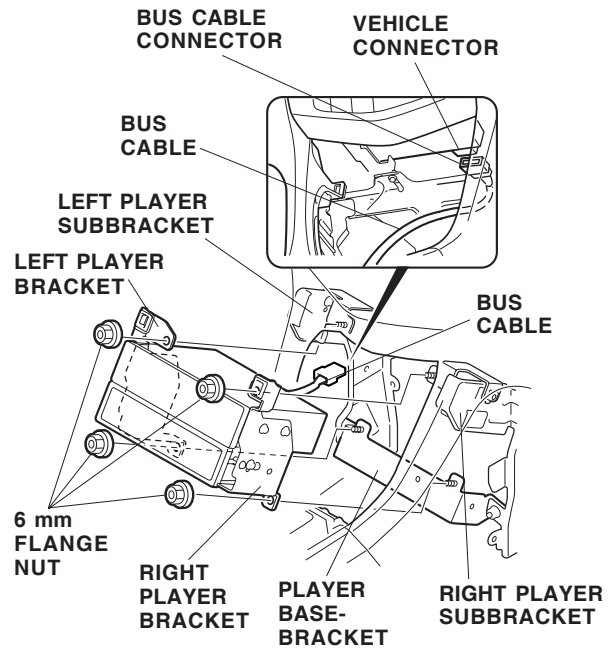

34. Attach the two grommet screws to the player panel in the square holes shown.

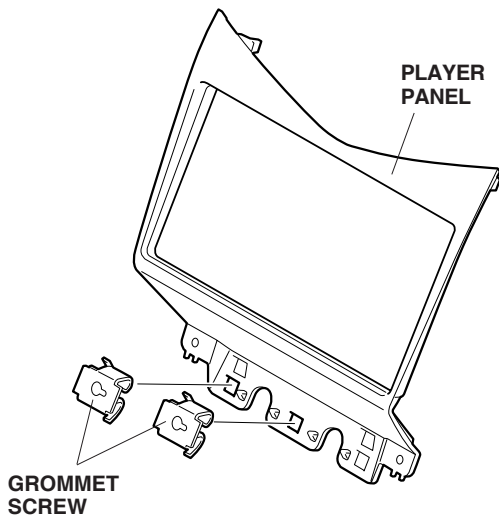

35. Using scissors cut one EPT sealer into three pieces.
36. Using isopropyl alcohol on a clean towel, wipe the player panel where the EPT sealers will attach. Attach the EPT sealer to the player panel, and cut off the excess.

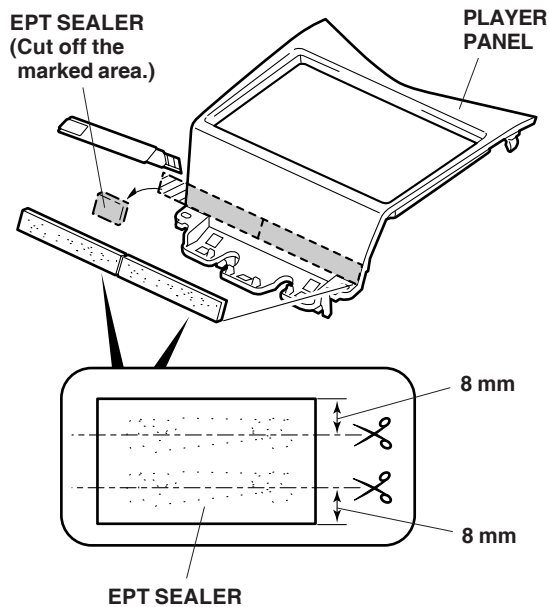

37. Remove the masking tapes attached in step 33.

38. Insert the player panel clips into latches, and attach the player panel to the instrument panel with the two self-tapping screws you removed in step 5.

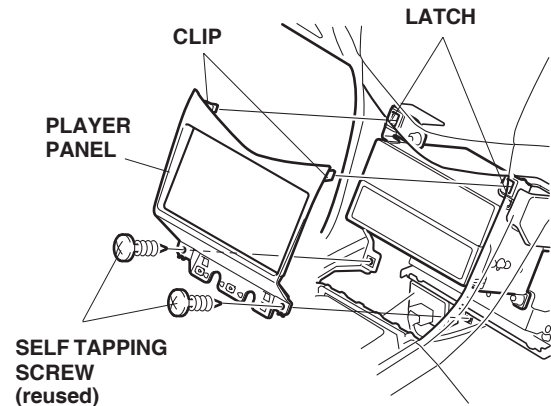

39. Check that all wire harnesses are routed properly and all connectors are plugged in.
40. Reconnect the negative cable to the battery.
41. Enter the customer's radio anti-theft code, and reset the radio station presets.
42. Set the clock.
43. Do an ECU idle learn procedure.
- Make sure all electrical items are turned off.
 - Start the engine. Hold the engine speed at 3,000 rpm with no load (in Park or neutral with the parking brake applied) until the radiator fan comes on.
 - Let the engine idle for about 5 minutes with the throttle fully closed and with all electrical items off.
- NOTE: If the radiator fan comes on during this step, the time when it is operating must not be included in the 5 minutes.
44. Check the operation of the player according to the Owner's Manual.
45. Put the player Owner's Manual in the glove box.
46. Reinstall all removed parts.
- NOTE: Whenever the battery is disconnected, the driver's window AUTO function is disabled.
47. Start the engine. Push down fully on the driver's window switch until the window is fully open.
48. Pull up fully on the driver's window switch to close the window completely, then hold the switch for 2 seconds.
49. Test the window AUTO function.