



INSTALLATION INSTRUCTIONS

Accessory
REAR VIEW CAMERA ATTACHMENT (EX WITH NAVIGATION)

Application
2005 PILOT

Publications No.
All 28069
Issue Date
SEP 2004

PARTS LIST

Attachment Kit (sold separately):
P/N 08B21-S9V-100

Rear camera cover

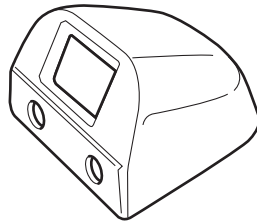

Rear camera bracket

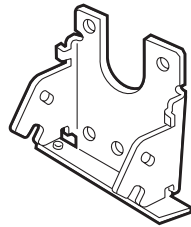

Rear camera subbracket

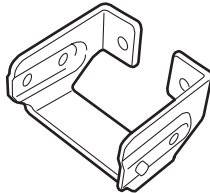

Rear camera base bracket

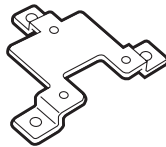

2 Control unit brackets

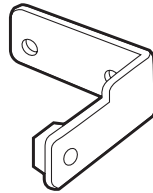

2 Control unit subbrackets

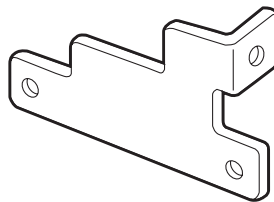

Control unit harness

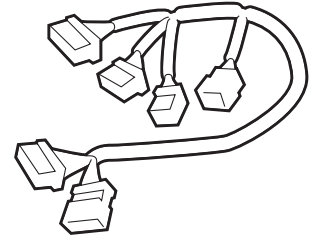

Rear camera subharness

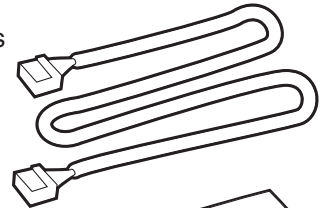

Template

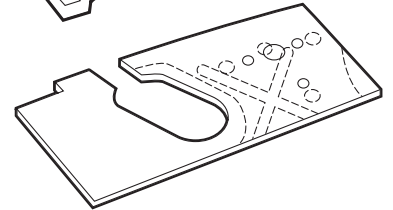

5 Cushion tapes
(1 not used)

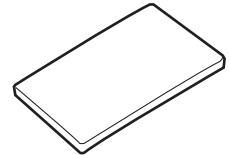

2 Unit cushion tapes

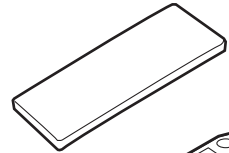

38 Wire ties
(4 not used)

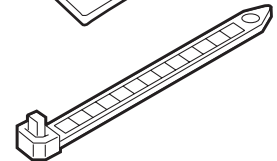

2 Washer-screws, 4 x 6 mm



3 Washer-screws, 4 x 12 mm



6 Washer-screws, 5 x 10 mm

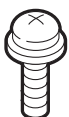

2 Allen bolts

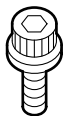

3 Stepped screws



3 Rivnuts



**Rear Camera Kit (sold separately):
P/N 08A21-2D1-100**

Rear camera

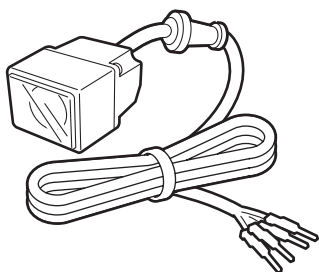

Control unit

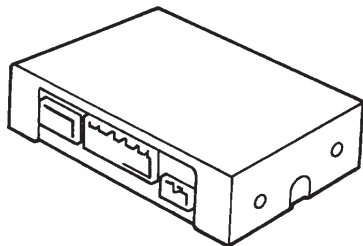

4-Pin connector

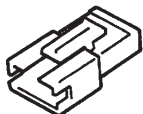

2 Washer-screw, 3.5 x 6 mm



Owner's Manual

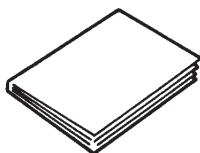

TOOLS AND SUPPLIES REQUIRED

Phillips screwdriver (#2, #3)

Flat-tip screwdriver

Small flat-tip screwdriver

Ignition key

6 mm, 8 mm, and 10 mm Combination wrenches

T-handle wrench

8 mm and 10 mm Sockets

Scissors

Shop towel

Drill

3 mm, 7 mm, 8 mm, 10 mm, and 14 mm Drill bits

File

Electrical tape

Isopropyl alcohol

3 mm Hex wrench

Touch-up paint

Center punch

Pushpin

Torque wrench

Piece of steel wire

Utility knife

Diagonal cutters

Clip removal tool

Silicone spray

Angle Phillips screwdriver

Illustration of the Rear Camera Installed on the Vehicle

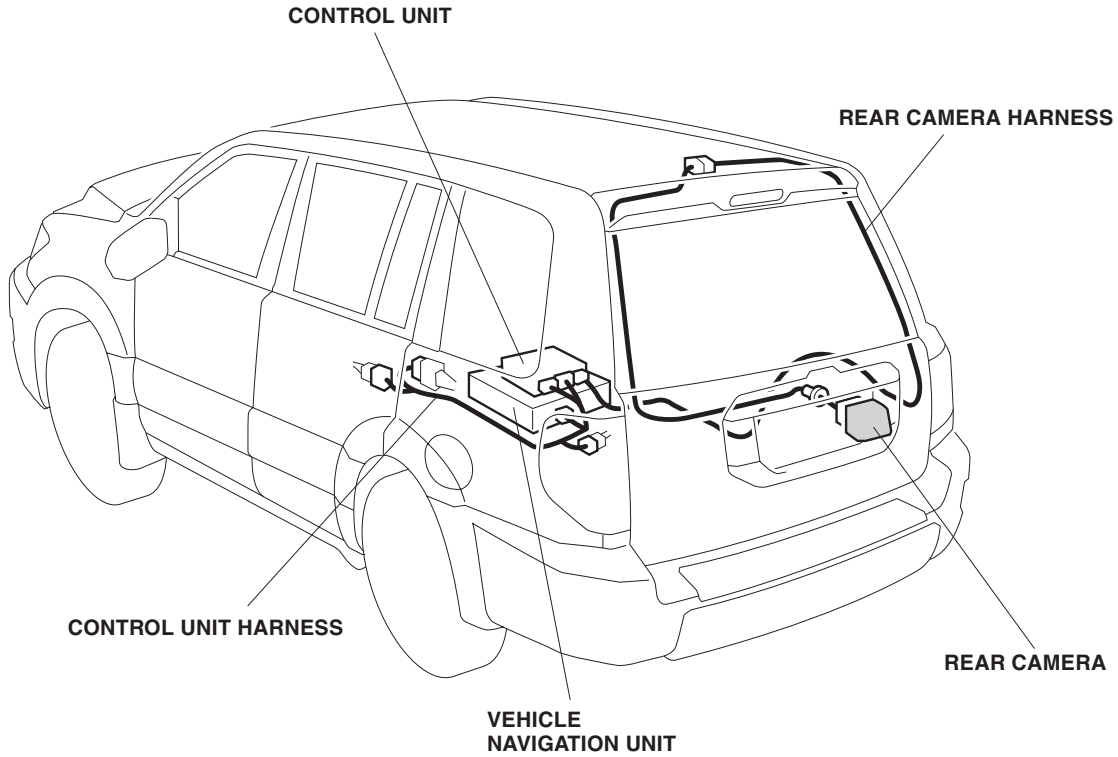

System Diagram

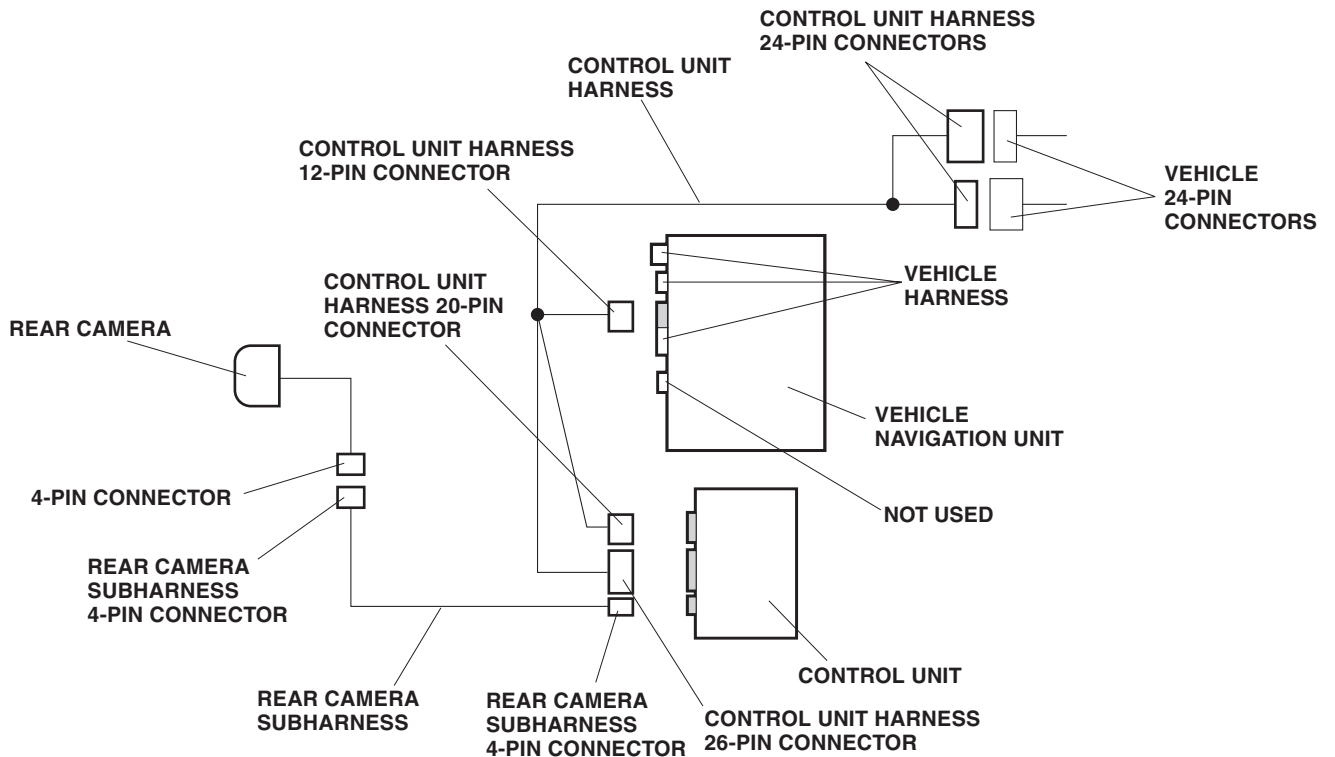

INSTALLATION

Customer Information: The information in this installation instruction is intended for use only by skilled technicians who have the proper tools, equipment, and training to correctly and safely add equipment to your vehicle. These procedures should not be attempted by “do-it-yourselfers.”

1. Make sure you have the anti-theft code for the radio, then write down the radio station presets. Make sure you have the navigation system security code.
2. Disconnect the negative cable from the battery.
3. Open the tailgate, release the two retaining tabs and four clips, and remove the tailgate upper trim.

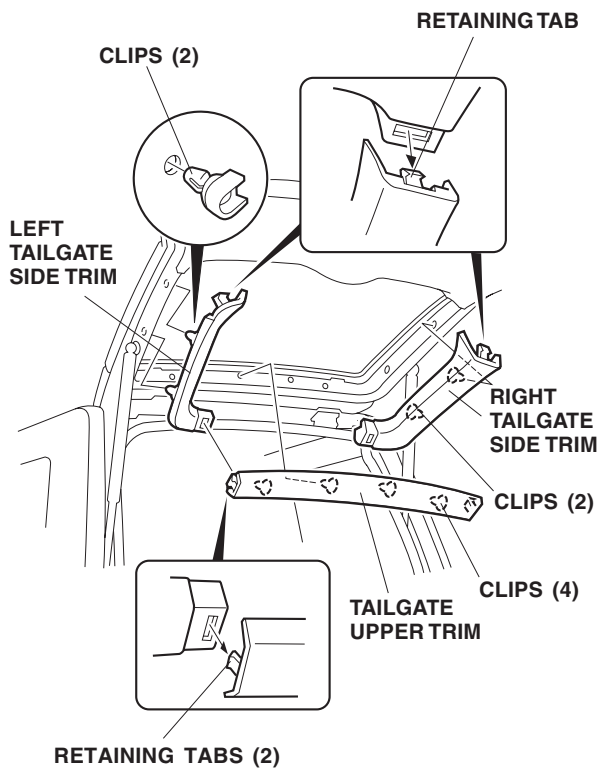

4. Release the one retaining tab and two clips, and remove the right and left tailgate side trims.

5. Remove the two lids from the grab rail, then remove the two screws concealed under the covers. Remove the grab rail.

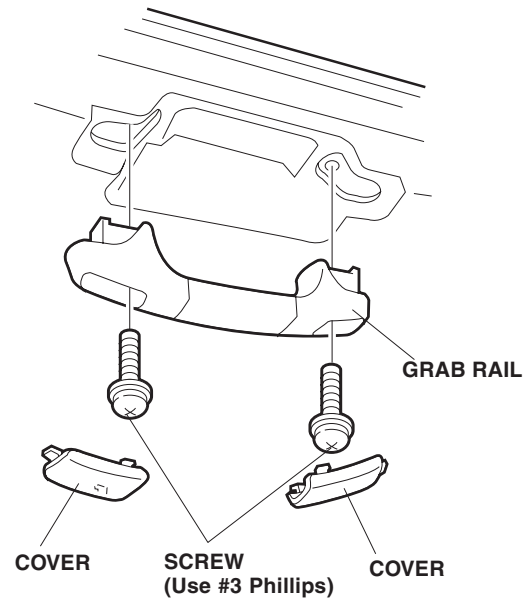

6. Release the two clips that secure the bottom of the tailgate rear trim.

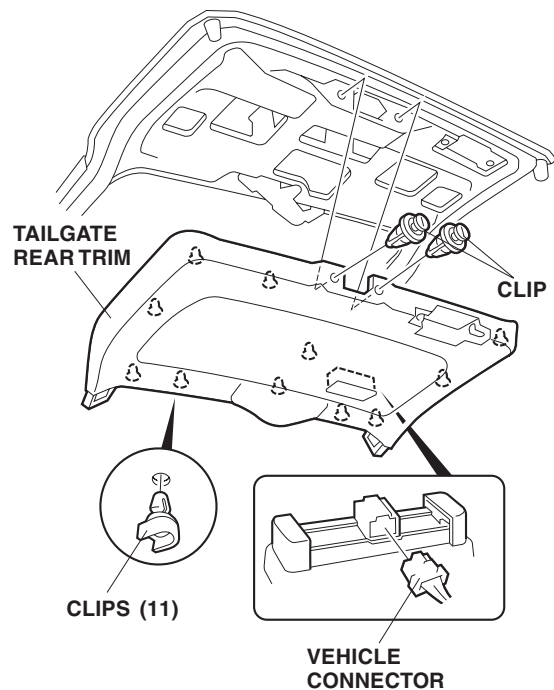

7. Release the eleven clips, and lift the tailgate rear trim up away from the tailgate.
8. Unplug the vehicle connector, and remove the tailgate rear trim.

- Disconnect the two vehicle connectors from the backup lights.

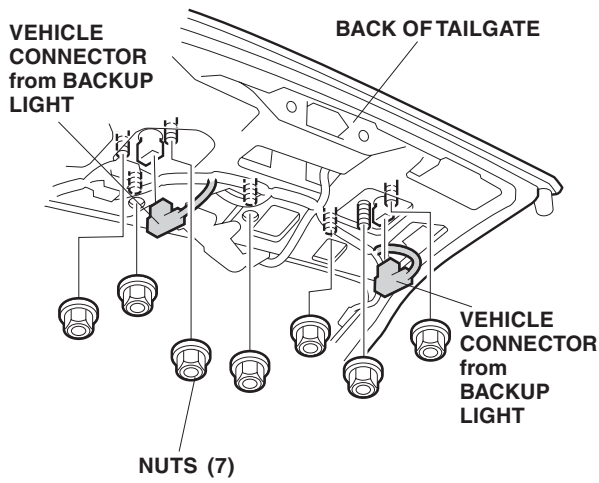

- Remove the seven nuts from the back of the tailgate.
- Remove the rear license plate trim. Release the three lower clips using an 8 mm combination wrench. Release the remaining clip using a clip remover. Do not pull on the license plate trim to remove the clip, or you will break the clip or the trim.

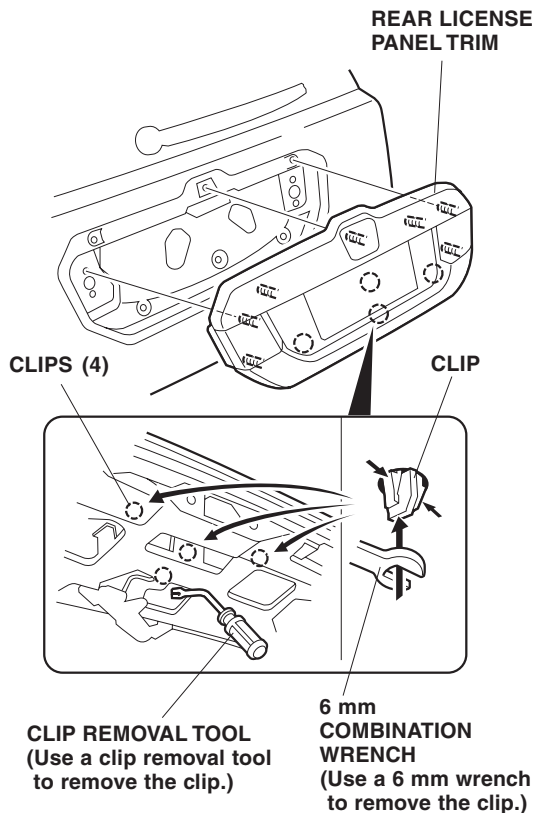

- Pull the rear cargo floor lid out toward you, and remove it.

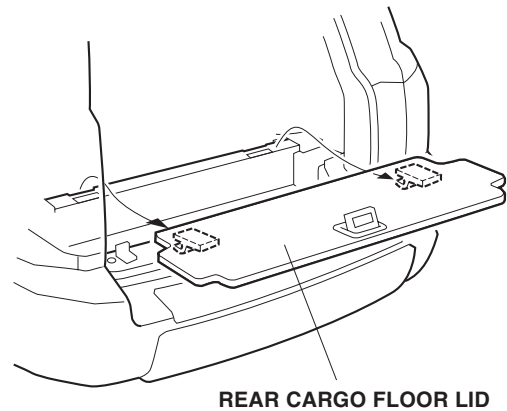

- Remove the tailgate weatherstrip in the area shown, then lift the rear panel trim to release the four clips and six retaining tabs. Remove the rear panel trim.

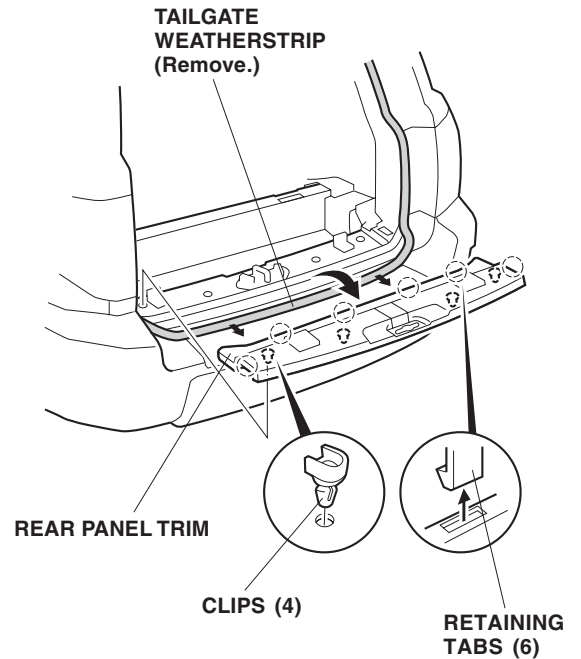

14. Using a small flat-tip screwdriver or an ignition key, release the seat belt lower hook from the right third row seat.

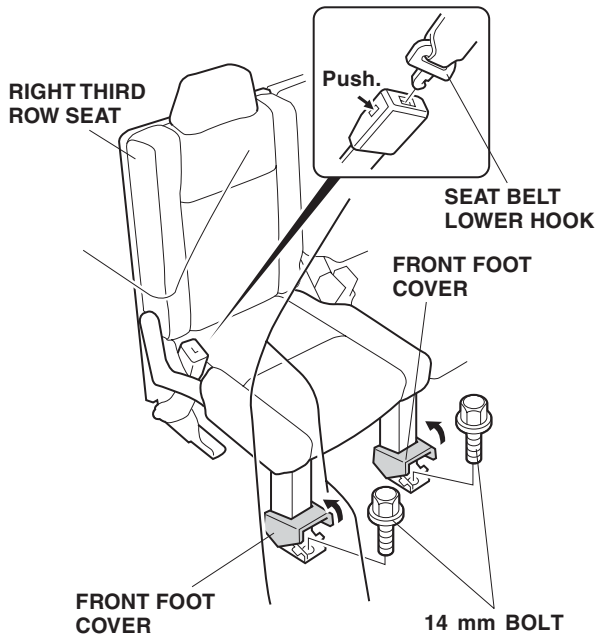

15. Pull up on the front foot covers of the right third row seat, and remove the two bolts concealed under the covers.
16. Raise the right third row seat cushion, then remove the four bolts that secure the rear feet. Remove the right third row seat.

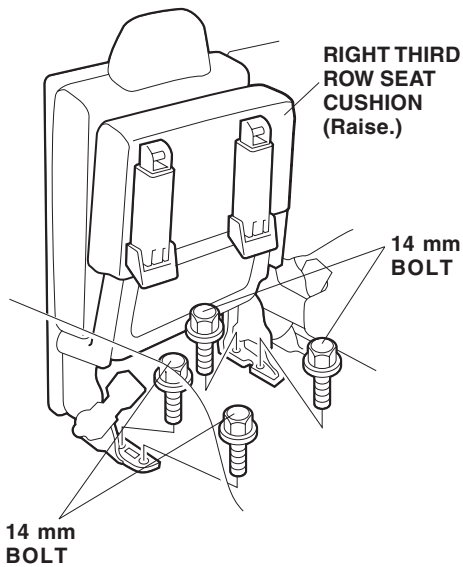

17. Remove the cover from the seat belt anchor, and remove the seat belt anchor bolt concealed under the cover.
18. Pull the top of the right quarter pillar trim out toward you to release the four clips and two retaining tabs, then remove the trim.

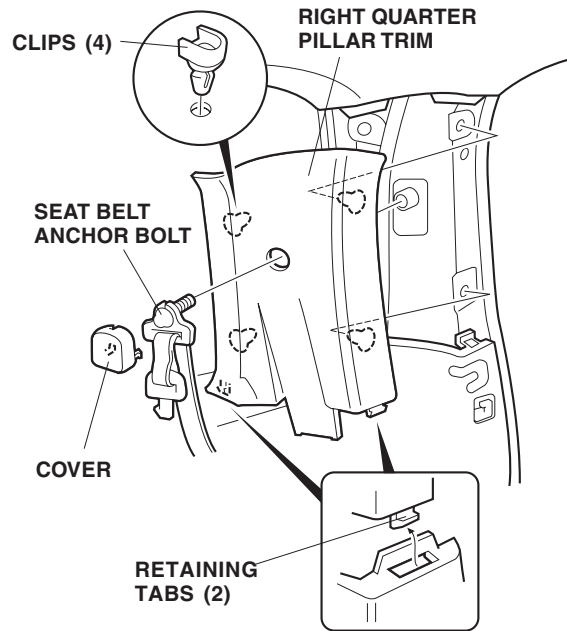

19. Remove the door weatherstrip from around the right rear door sill. Pry up on the two retaining tabs and three clips, and remove the right rear door sill.

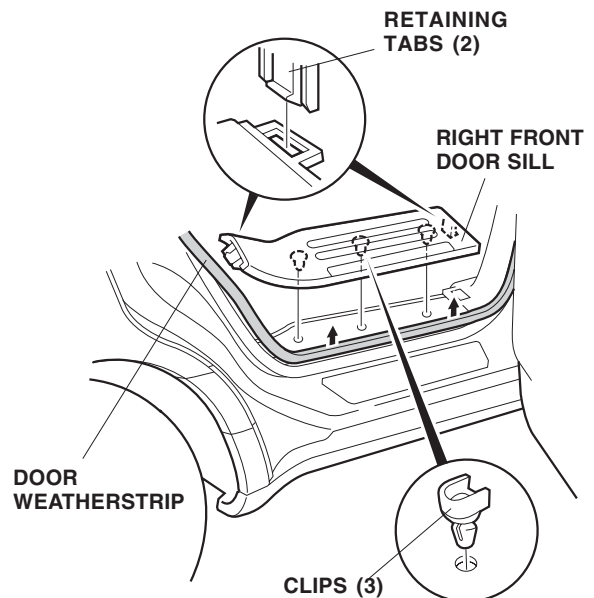

20. Remove the three tie-down hooks (one screw for each). Remove the two floor clips.

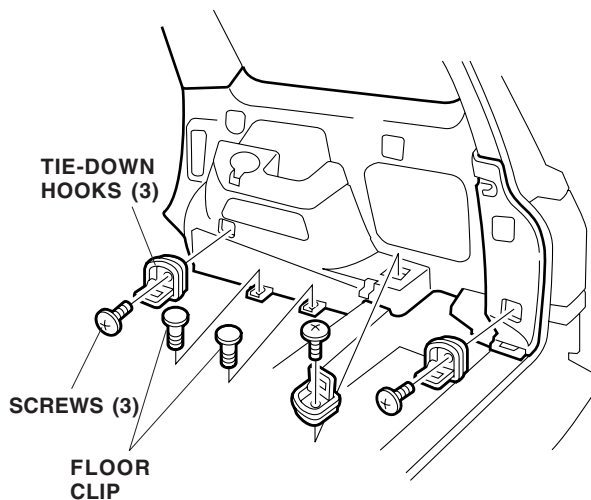

21. Remove the large plastic cover, and remove the screw concealed under the cover. Pry out the two small plastic covers and remove the two self-tapping screws. Tilt the cargo net hooks down, and remove the two self-tapping screws.

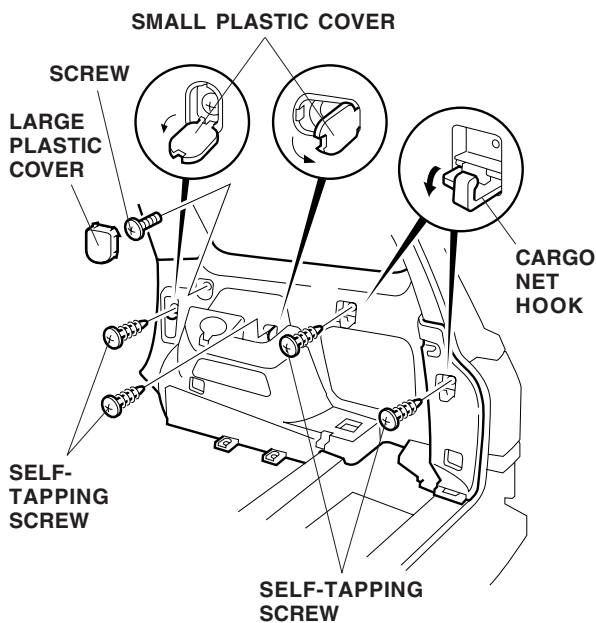

22. Pull the right rear side lining toward you to release the six clips, then unplug the connector at the rear of the right side lining. Remove the lining.

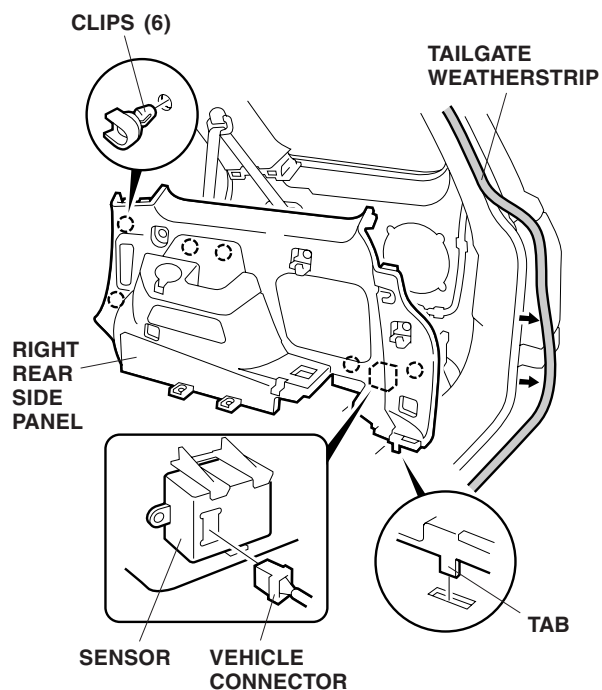

23. Pry up on the two retaining tabs and three clips, and remove the right front door sill.

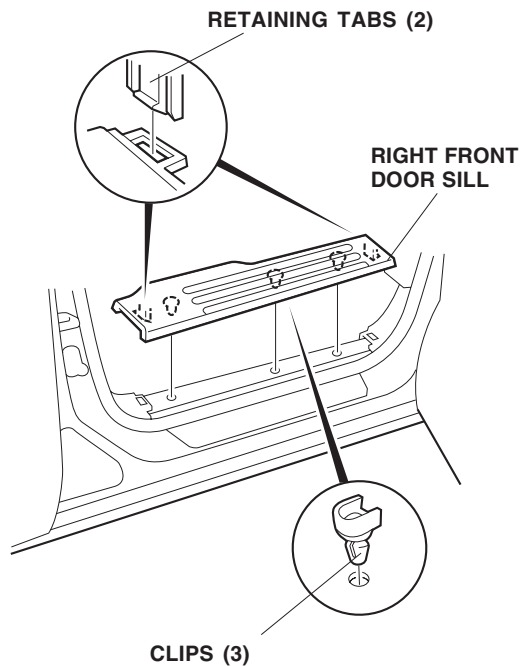

24. Remove the center pillar anchor bolt.

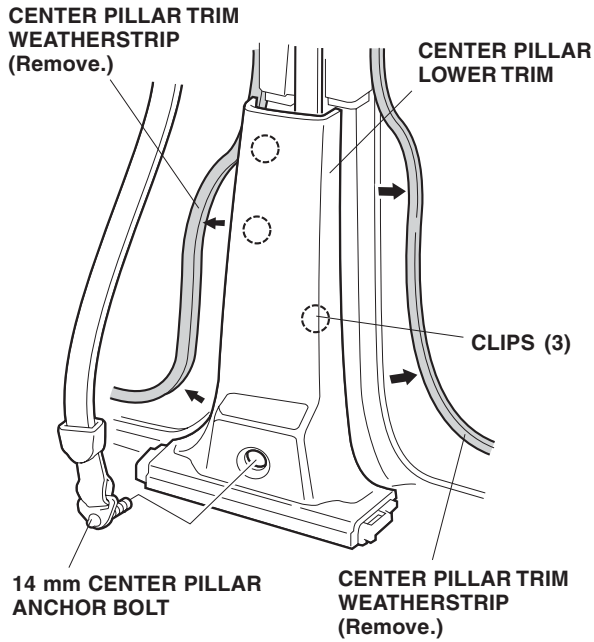

25. Remove the center pillar trim weatherstrip. Pull the center pillar lower trim out toward you to release the three clips, and remove the trim.

26. Release the four clips, and remove the rear seat frame cover from the passenger's seat.

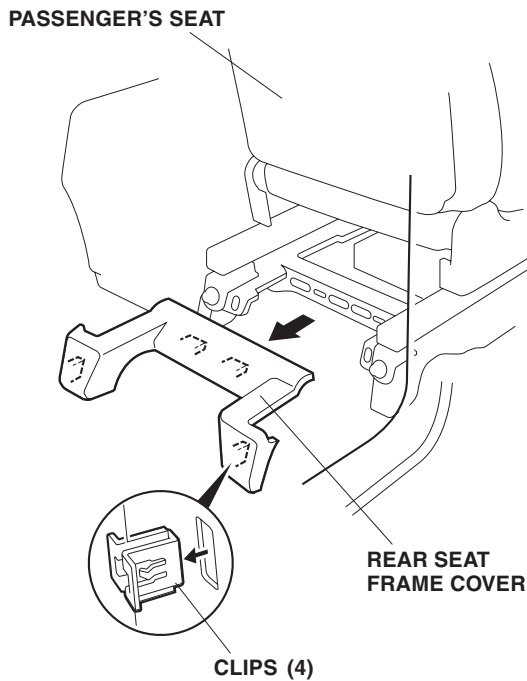

27. Release the four clips, and remove the front seat frame cover from the passenger's seat.

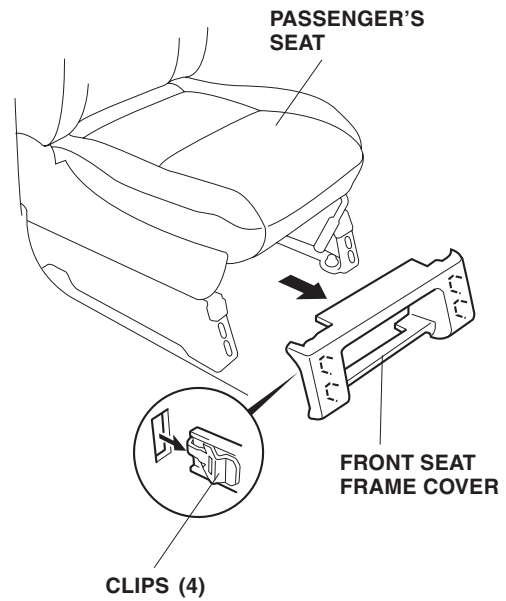

28. Remove the two top bolts and two front bolts that secure the passenger's seat side rail to the floor.

29. Move the passenger's seat out of way.

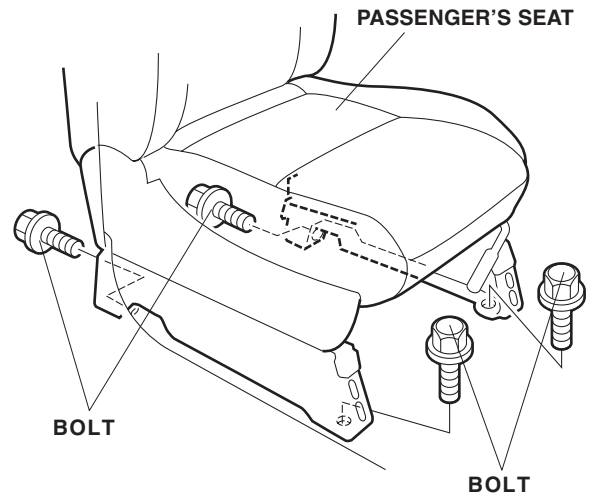

30. Pry up on the seven clips, and remove the center console lower cover.

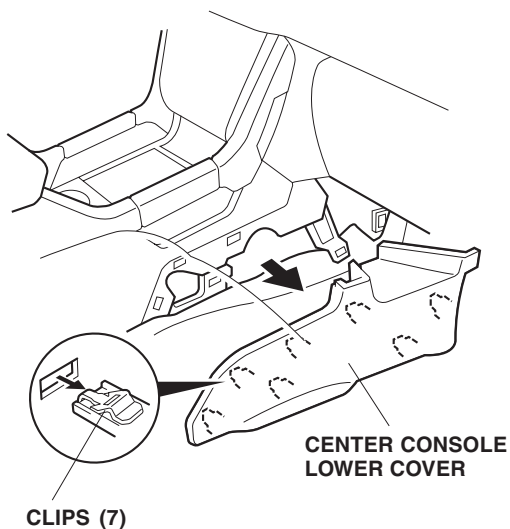

Installing the Rear Camera and Routing the Camera Harness

31. Align the template with the rear license panel trim as shown, then mark the trim at each of the four marks with a pushpin as shown. Remove the template.

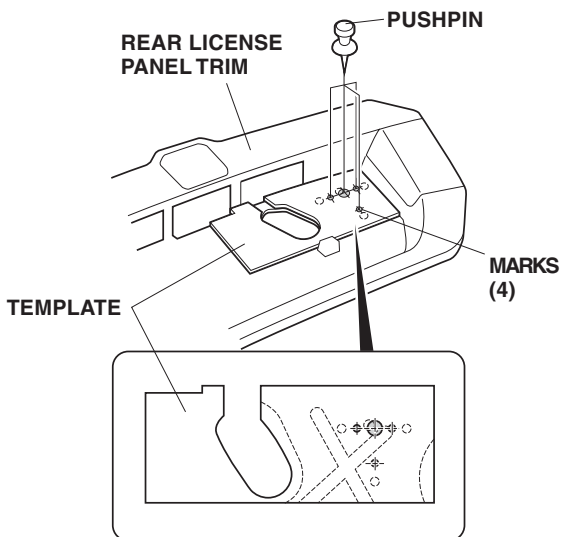

32. To prevent damage, wrap electrical tape around the drill bit at a point about 30 mm away from the tip. While wearing eye protection, drill a 3 mm hole, then a 7 mm hole in 3 places, and finally a 14 mm hole in 1 place. After drilling, remove any burrs from the edges of the holes with a file, and apply touch-up paint.

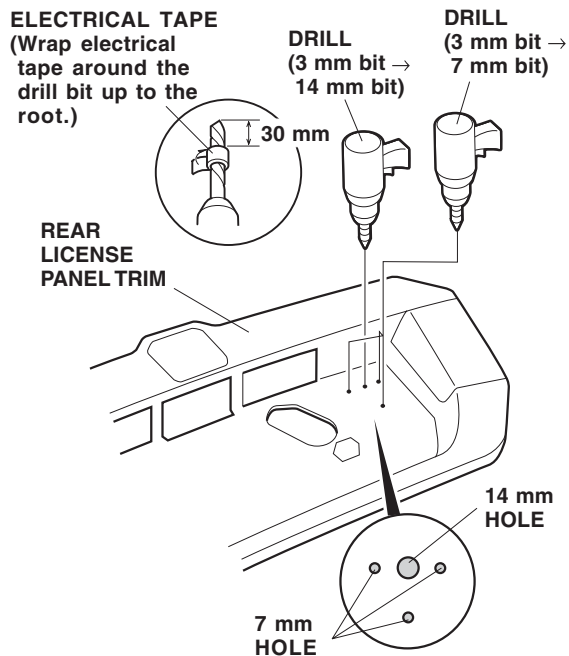

33. Using scissors, cut out the marked area from the template along the dotted lines, then tape the template on the tailgate as shown. Lightly center-punch the tailgate at each of the four marks indicated on the template.

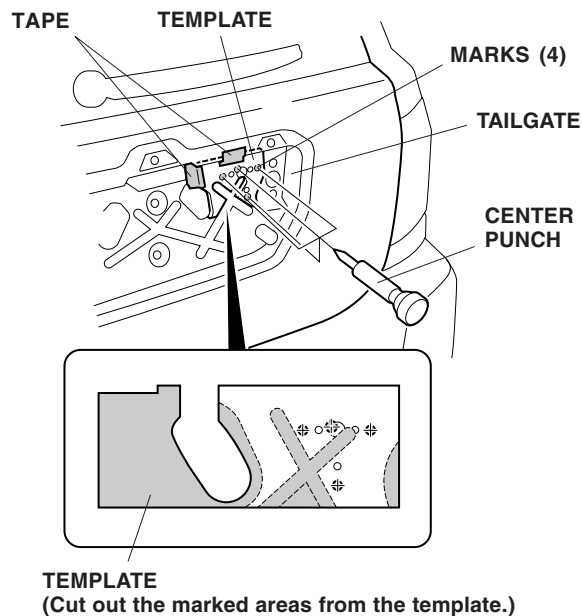

34. Remove the template. To prevent damage to the inner parts, wrap electrical tape around the drill bit 30 mm from the tip. While wearing eye protection drill a 3 mm hole, then an 8 mm hole in 3 places, and finally with a 10 mm hole in 1 place. Remove any burrs from the edges of the holes with a file, and apply touch-up paint. Allow the touch-up paint to dry thoroughly.

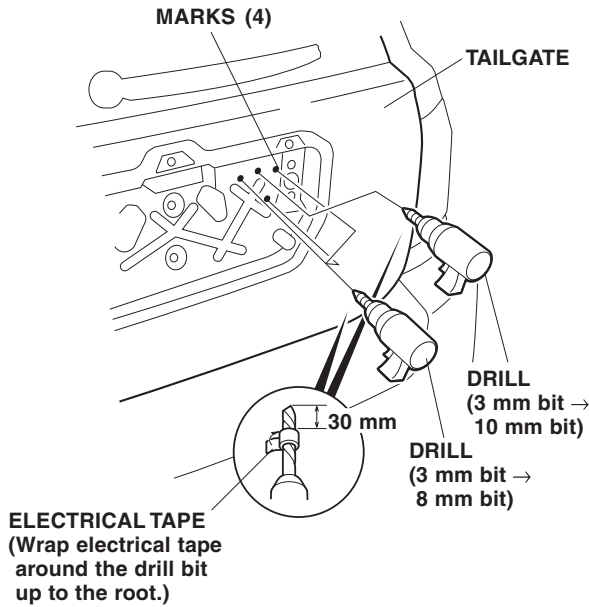

35. Install three rivnuts in the 8 mm holes you just made.

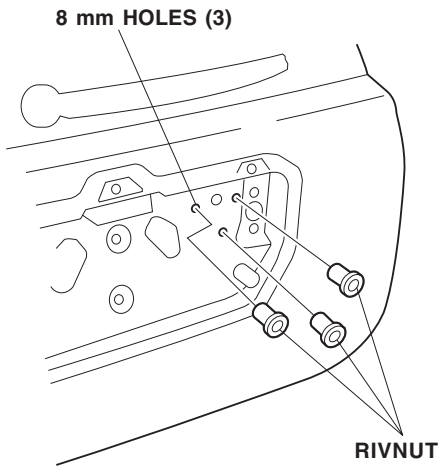

36. Install the rear camera base bracket to the tailgate with three 4 x 12 mm washer-screws.

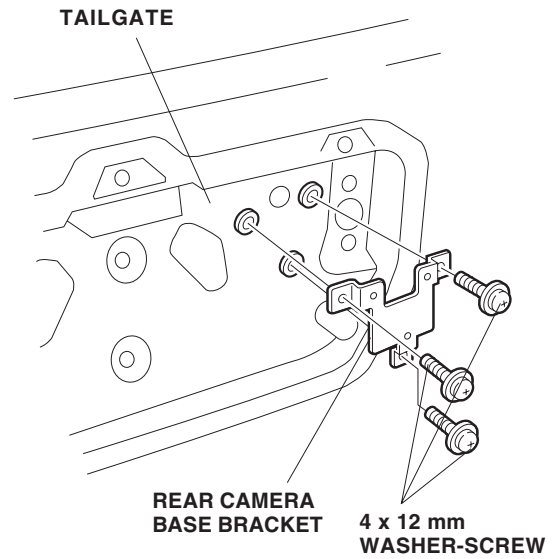

37. Route the rear camera harness through the 14 mm and 10 mm holes, then seat the camera harness grommet into the 10 mm hole.

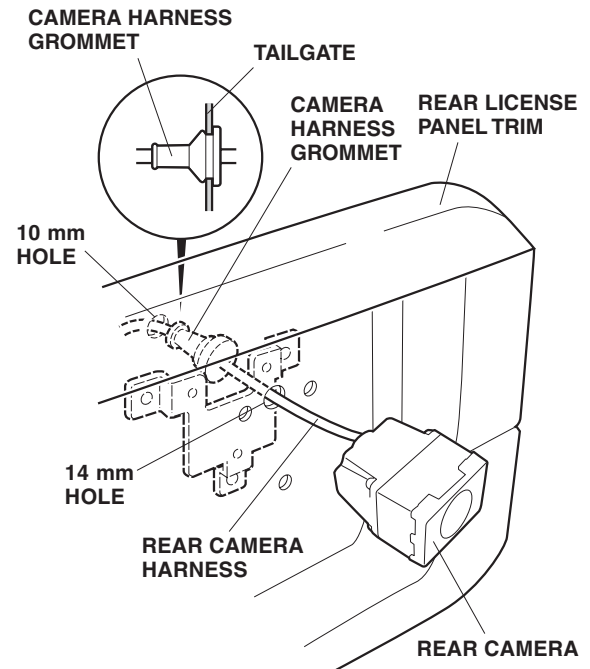

38. Reinstall the rear license panel trim on the tailgate.

39. Remove and discard rubber washers from the stepped screws. Position the rear camera bracket on the rear license panel trim, and install the three stepped screws.

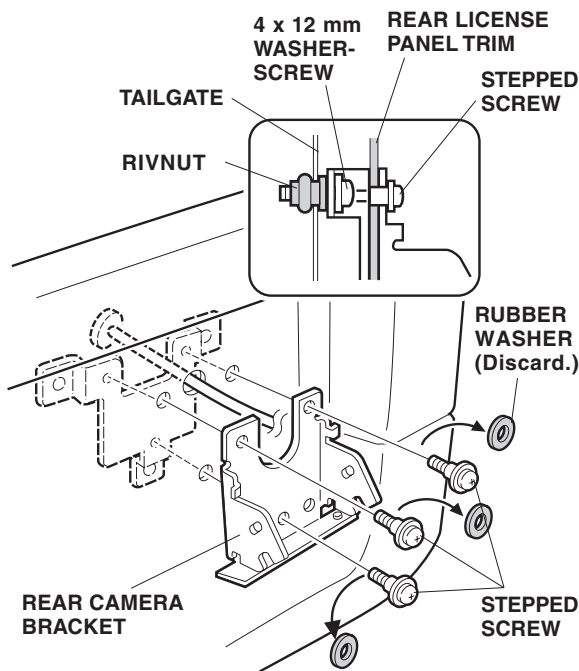

40. Slide the rear camera into position on the rear camera subbracket, and install the two 3.5 x 6 mm washer-screws included in the Rear Camera Kit. Note the direction of the rear camera, the beveled side faces down.

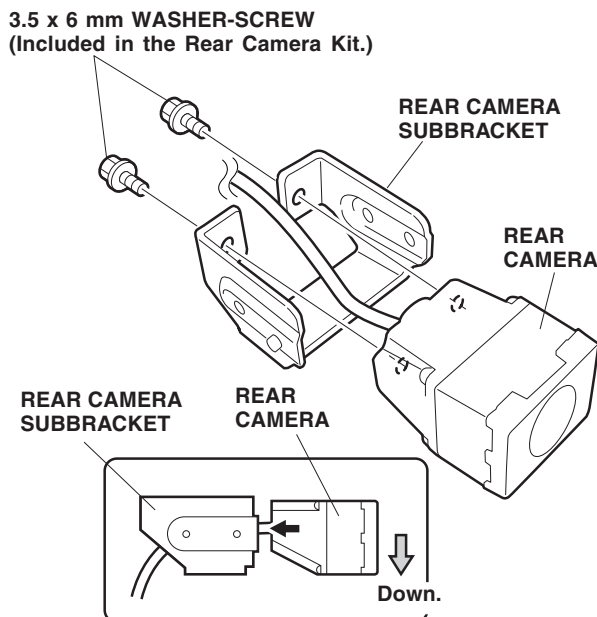

41. Align the two locating tabs on the rear camera subbracket with the slots in the rear camera bracket. Facing the camera, tighten the right side screw using an angle Phillips screwdriver.

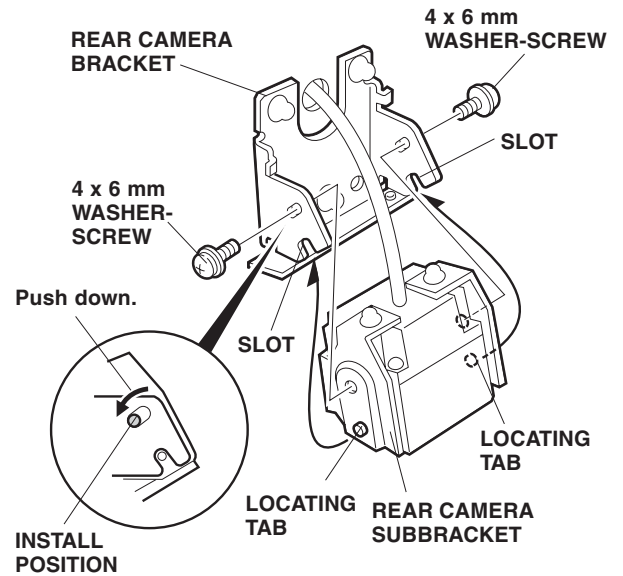

42. Install the two 4 x 6 mm washer-screws.
43. Route the rear camera harness along the vehicle harness as shown.

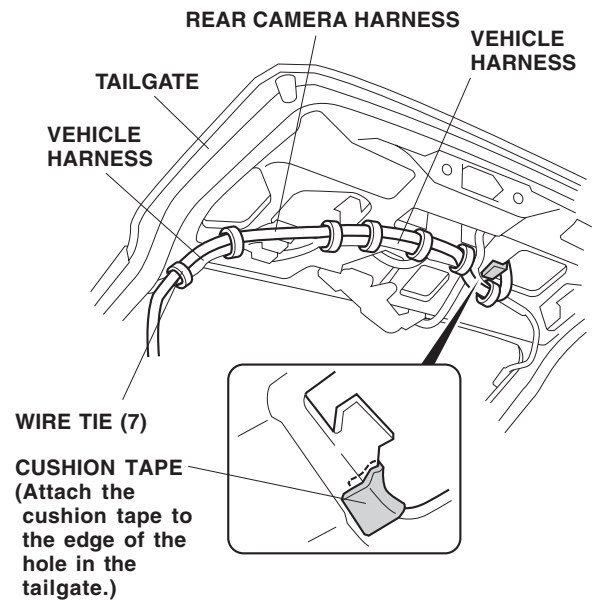

44. Using isopropyl alcohol, clean the area where the cushion tape will attach. Attach the cushion tape to the edge of the hole in the tailgate.
45. Secure the rear camera harness to the vehicle harness with seven wire ties in the areas shown.

46. Route the rear camera harness along the vehicle harness, then secure it to the vehicle harness with seven additional wire ties in the areas shown.

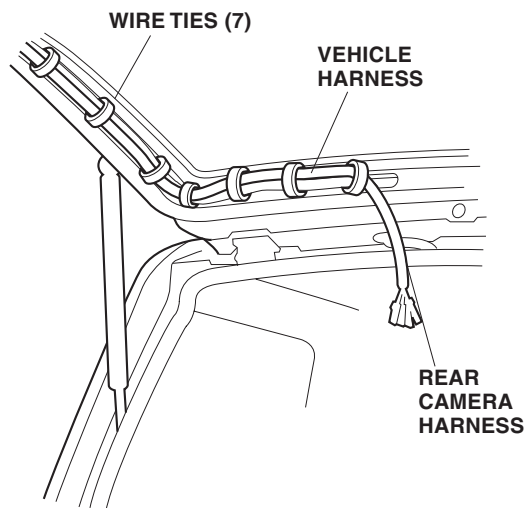

47. Remove the existing grommet from the tailgate.
48. Remove the tailgate weatherstrip in the area shown. Release the two clips, and pull the roof lining out in the direction shown. Carefully pull the lining out so it will not be wrinkled.

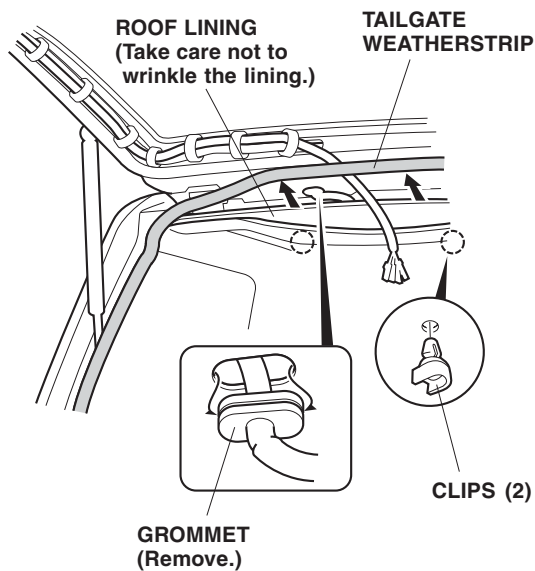

49. Wrap one cushion tape around the camera harness where it will contact the edge of the hole in the tailgate.

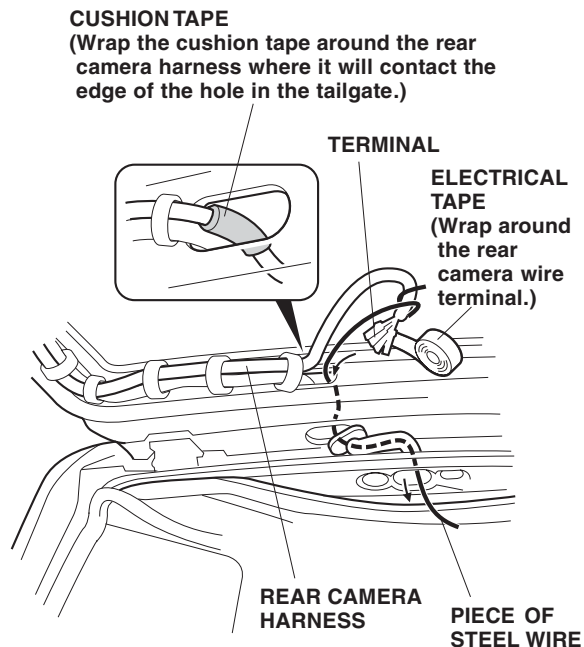

50. Wrap electrical tape around the terminal of the rear camera harness. Tie a piece of steel wire to the terminal end of the camera harness, lube the camera harness with silicone spray. Pull the harness into the cabin through the grommet. If the camera harness sticks to the grommet, stop pulling and back out the harness. Add more lube and try again. Excessive pulling can break the camera harness.

- Remove the electrical tape and the piece of steel wire from the terminal of the rear camera harness. Plug the terminals of the rear camera harness into the 4-pin connector as shown. Secure the rear camera harness to the vehicle harness with two wire ties.

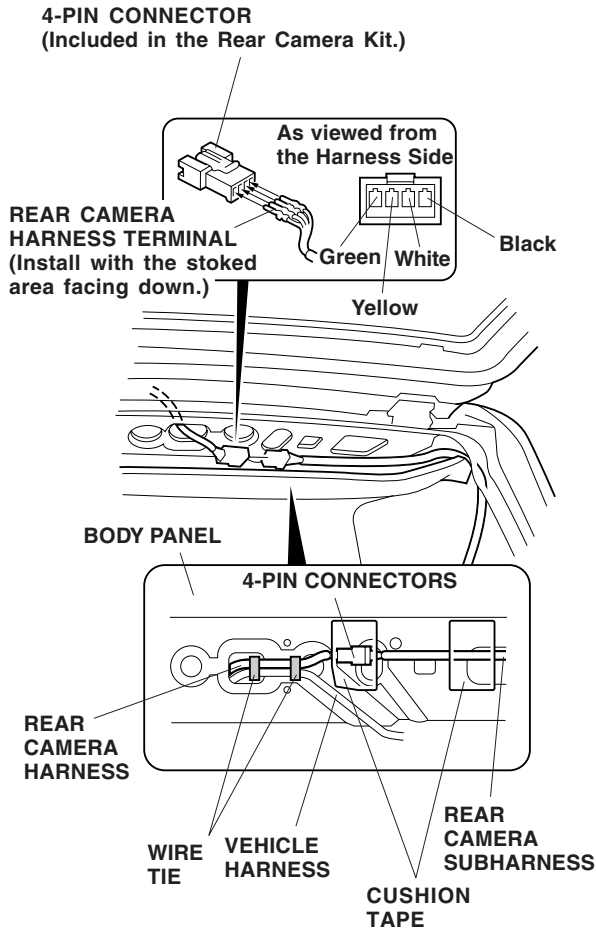

- Connect 4-pin connector to the rear camera subharness 4-pin connector, then route the rear camera subharness to the right of the vehicle.
- Using isopropyl alcohol, clean the areas where the cushion tapes will attach. Secure the rear camera subharness to the body panel with two cushion tapes in the areas shown.

- Pull the rear camera subharness out from the roof lining, then route it along the vehicle harness as shown.

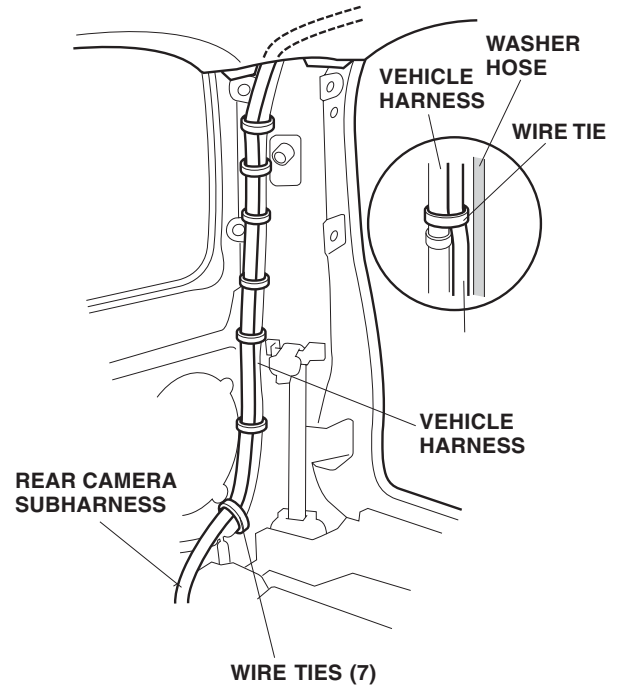

- Secure the rear camera subharness to the vehicle harness with seven wire ties in the areas shown. Do not attach the wire ties to the windshield washer hose.

56. Route the rear camera subharness along the vehicle harness to the front, then secure it to the vehicle harness with eight wire ties.

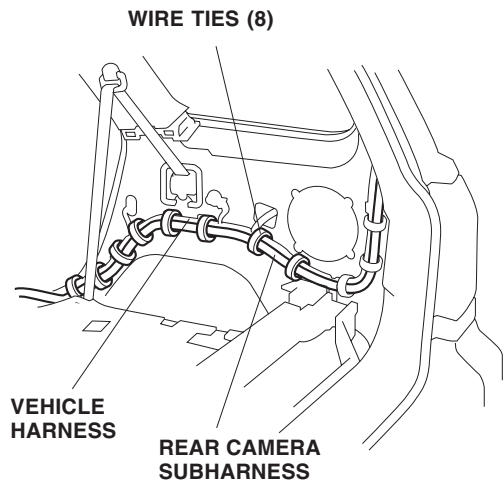

57. Continue routing the rear camera subharness forward and under the passenger's seat, secure it to the vehicle harness with three wire ties.

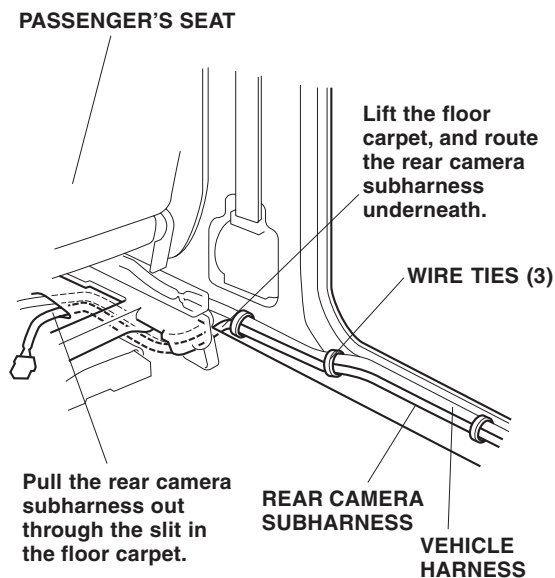

Installing the Rear Camera Control Unit

58. Remove the four nuts that secure the navigation system control unit to the bottom of the passenger's seat.

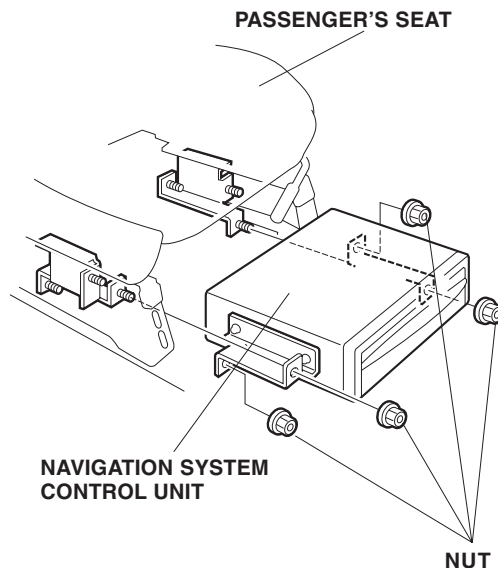

59. Remove the four screws that secure the navigation system control unit bracket.

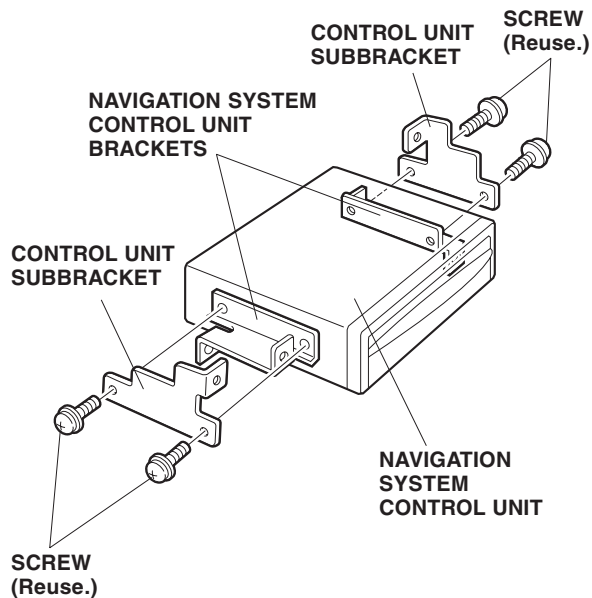

60. Position the two control unit subbrackets and the navigation system control unit brackets on the navigation system control unit, and reinstall the four screws.

61. Reinstall the navigation system control unit with the four nuts removed in step 58.

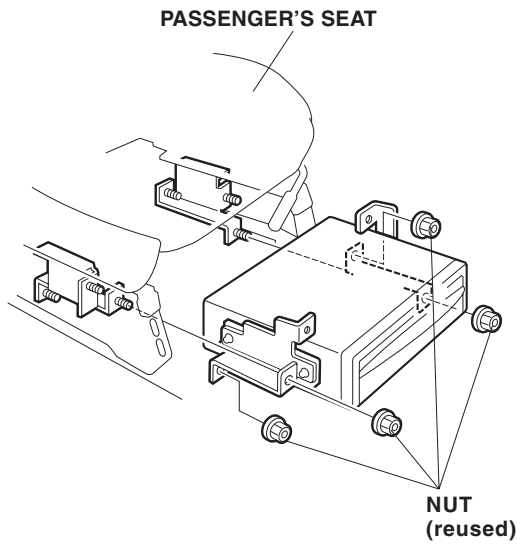

62. Position the two control unit brackets on the sides of the control unit, and install four 5 x 10 mm washer-screws.

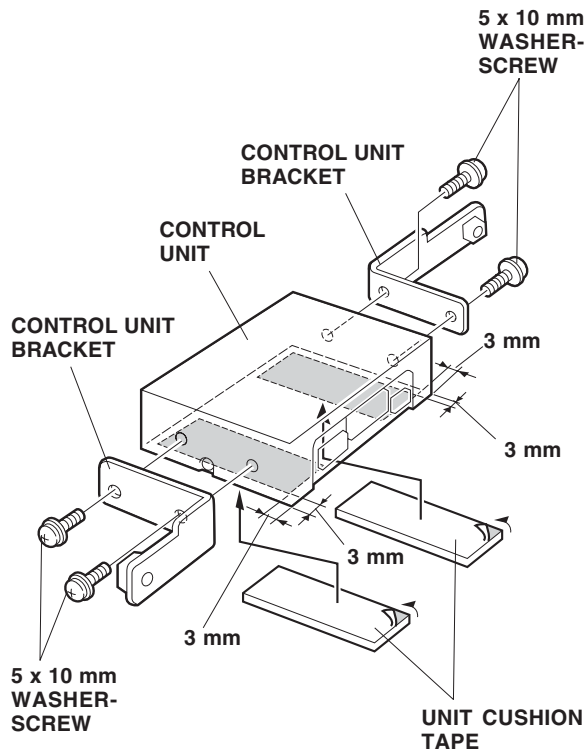

63. Using isopropyl alcohol, clean the areas where the unit cushion tapes will attach. Attach the two unit cushion tapes to the bottom of the control unit in the areas shown.

64. Attach the control unit brackets to the control unit subbrackets with two 5 x 10 mm washer-screws.

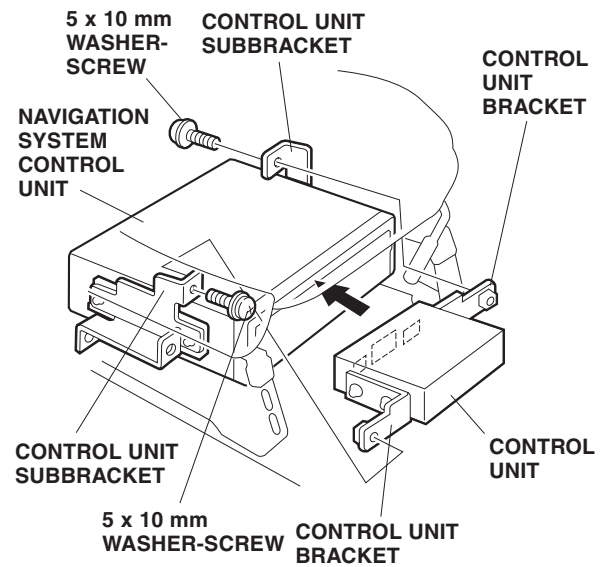

65. Plug the rear camera subharness 4-pin connector and the control unit harness 20-pin and 26-pin connectors into the rear of the control unit.

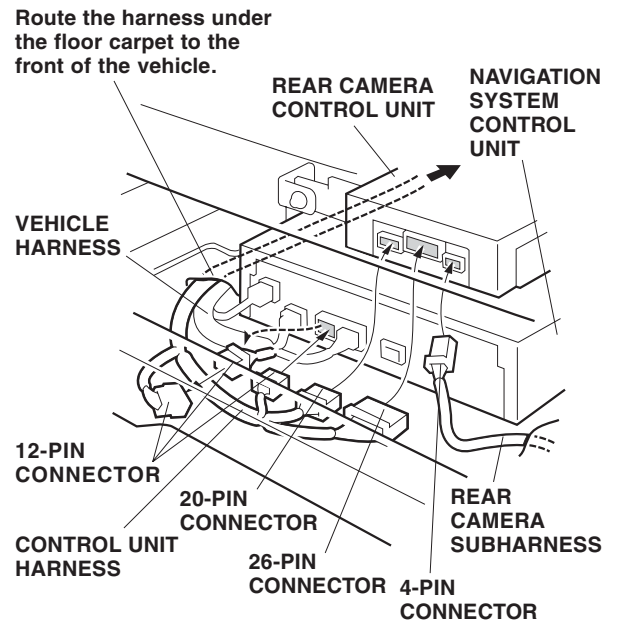

66. Unplug the vehicle 12-pin connector from the navigation system control unit, and plug in the control unit harness 12-pin connectors in between.

67. Route the other end of the control unit harness under the floor carpet toward the front of the vehicle.

68. Secure the control unit harness to the vehicle harness with one wire tie.

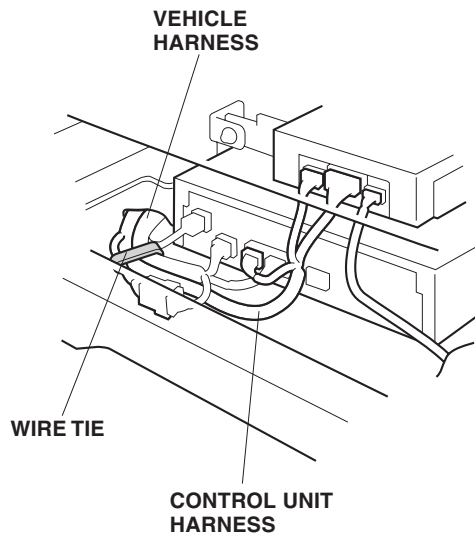

69. Pull the control unit harness out from under the floor carpet.

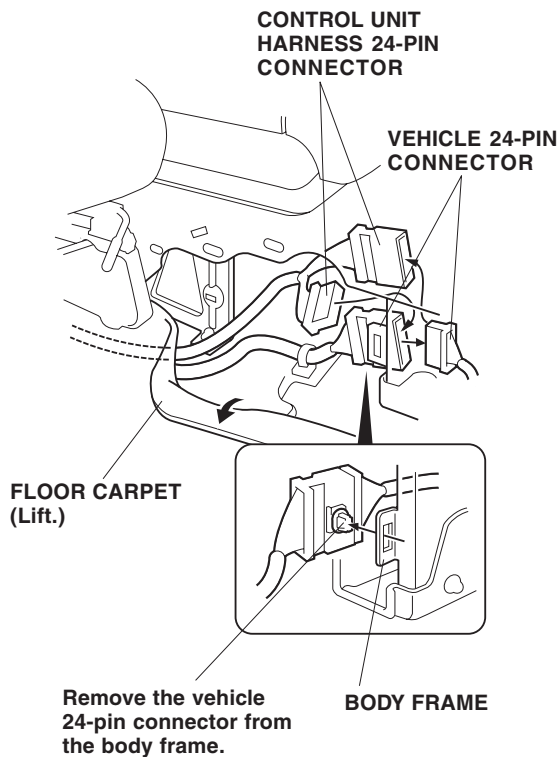

70. Remove the clip that secures the vehicle 24-pin connectors from the body frame. Unplug the vehicle 24-pin connector, and plug in the control unit harness 24-pin connectors in between.

71. Slide the control unit harness 24-pin connector into the vehicle 24-pin connector clip, and reinstall the vehicle 24-pin connector to the body frame.

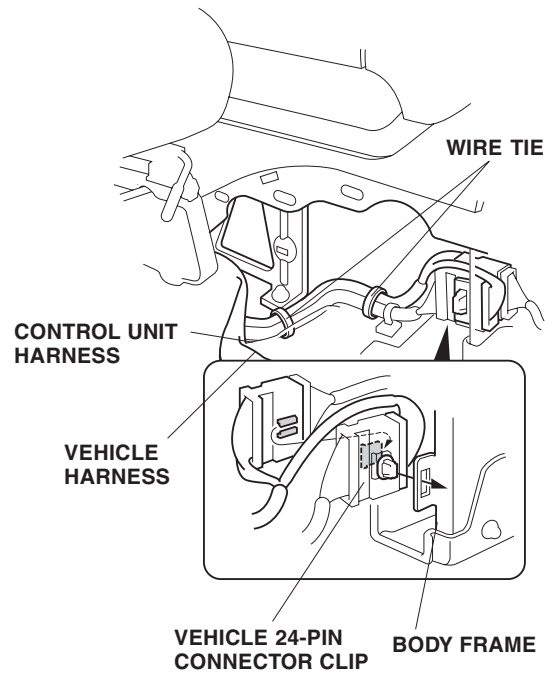

72. Secure the control unit harness to the vehicle harness with two wire ties.

Rear Camera Setting Procedure

73. Reconnect the negative cable to the battery.
74. Turn vehicle power on.

NOTE: Move the vehicle outside to acquire a GPS satellite signal. This could take up to 10 minutes. The following conditions must be met

- Engine must be running
- Vehicle must be parked outside
- Do not move the vehicle at this time.

75. The vehicle navigation system display will appear. Press OK and follow the on-screen instructions to continue. Enter the 4 digit navigation system security code.

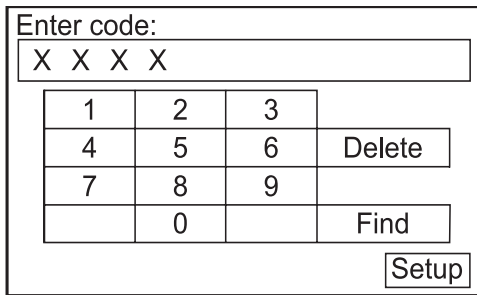

76. On the right of the navigation monitor, press the menu, map/guide and cancel buttons down in sequence, and hold for about 5 seconds. The display will be changed to "Diagnosis Menu."

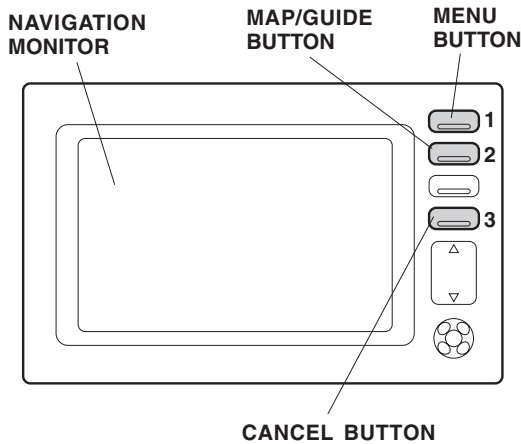

77. On the monitor screen, select "Rear Camera." The display will be changed to "Rear Camera Setting."

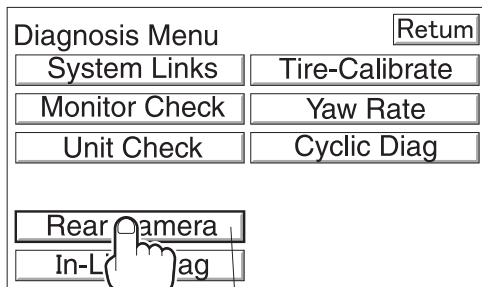

Select "Rear Camera"

78. Press the OFF button, After making sure that the OFF button is changed to the ON button, touch "Return." The display will be returned to the original display.

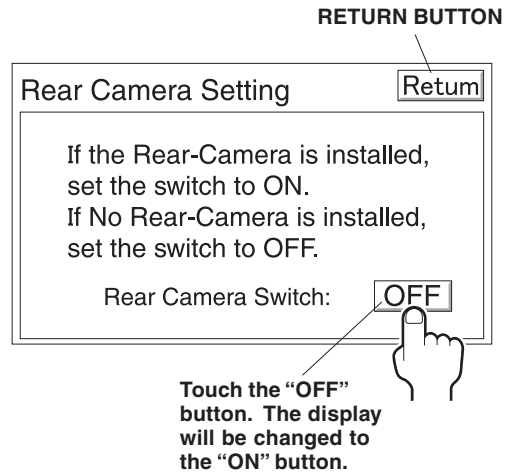

79. Install the camera cover with two socket bolts, then check that the camera cover is shown evenly on the screen.

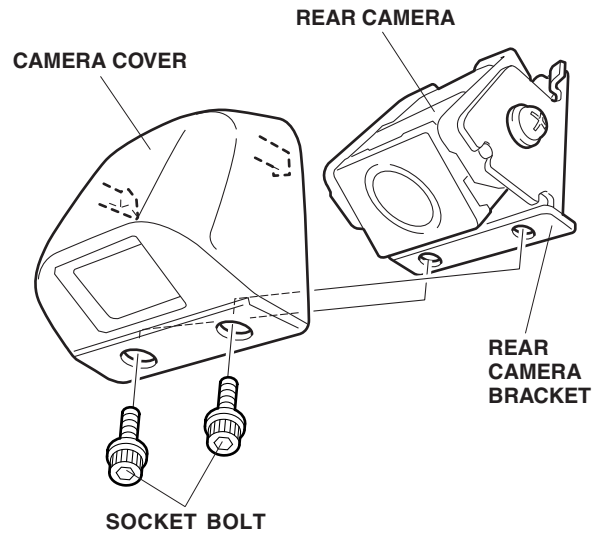

80. Reinstall all removed parts.
 - Torque the seat bolts to 41 to 53 N·m (30.3 to 39 lb-ft).
 - Torque the seat belt anchor bolts to 30 to 35 N·m (21.6 to 25.2 lb-ft).
81. Enter the customer's radio anti-theft code, and reset the radio station presets.
82. Set the clock.
83. Check the operation of the rear camera according to the Owner's Manual supplied with the unit.
84. Put the rear camera Owner's Manual in the glove box.

NOTE: Whenever the battery is disconnected, the driver's window AUTO function is disabled.

85. Start the engine. Push down on the driver's window switch until the window is fully open.
86. Pull up on the driver's window switch to close the window completely, then hold the switch for 2 seconds.
87. Test the AUTO up function.