

INSTALLATION INSTRUCTIONS

FRONT LOWER TRIM P/N 08P01-S9V-110	Accessory	Application 2005 PILOT	Publications No. All 28063
			Issue Date SEP 2004

PARTS LIST

Front lower trim

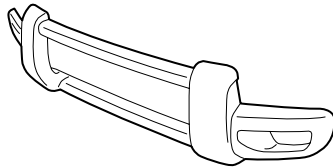

8 Long stepped bolts



4 Short stepped bolts



TOOLS AND SUPPLIES REQUIRED

- Phillips screwdriver
- Flat-tip screwdriver
- Ratchet
- 10 mm Socket
- 10 mm Combination wrench
- Hacksaw blade
- Drill
- 3 mm, 6 mm, and 10 mm Drill bits
- 12 mm Hole saw
- File
- Masking tape
- Blanket
- Felt-tip pen

INSTALLATION

Customer Information: The information in this installation instruction is intended for use only by skilled technicians who have the proper tools, equipment, and training to correctly and safely add equipment to your vehicle. These procedures should not be attempted by "do-it-yourselfers."

NOTE: Be extremely careful not to damage the body paint finish.

1. Open the hood, release eleven short clips and remove the bulkhead cover.

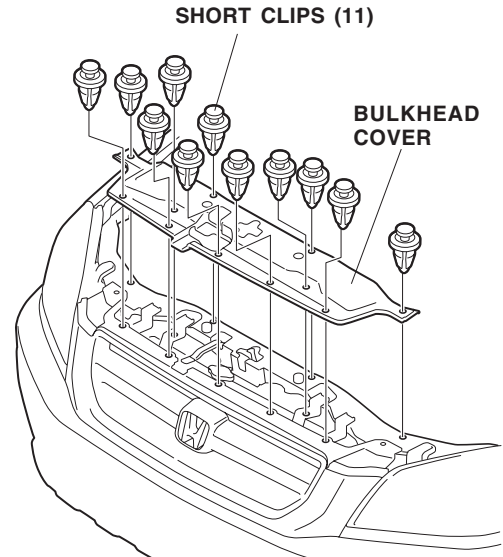

2. Remove two short clips, two self-tapping screws, four bolts and two long clips, then remove the front bumper by pulling it out toward you. To prevent damage, rest the bumper on a blanket.

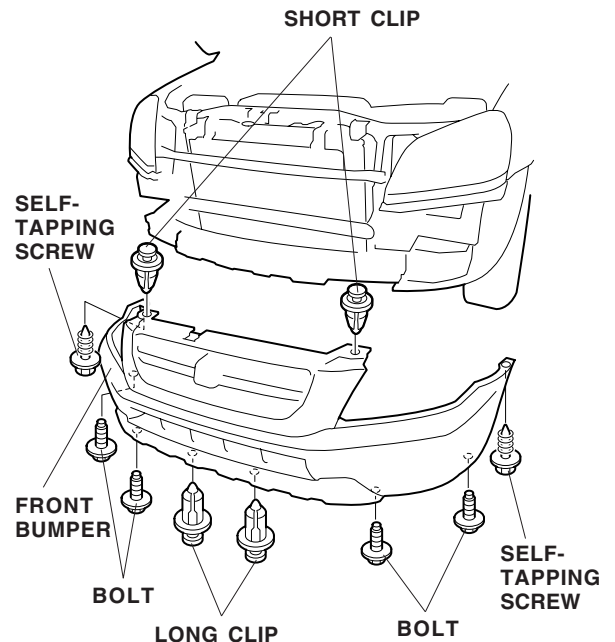

- Remove ten self-tapping screws, and remove the bumper cover from the front bumper.

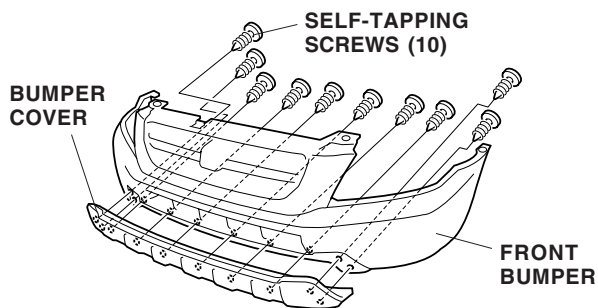

- While wearing eye protection, drill a 10 mm hole through the bumper cover at each of the four marks shown.
 - First drill with a 3 mm drill bit, and finish with a 10 mm drill bit.
 - Remove any burrs from the edges of the holes with a file.
 - When drilling holes through the bumper cover at the two lower marks, wrap masking tape around the drill bit at a point 10 mm away from the tip.

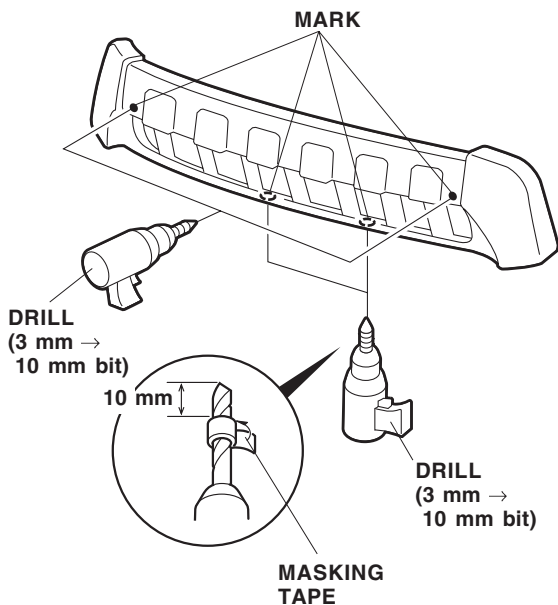

- Locate two scribed lines on the inside of the bumper cover. Measure 10 mm upward, and 5 mm downward as shown, and mark the bumper with a felt-tip pen.

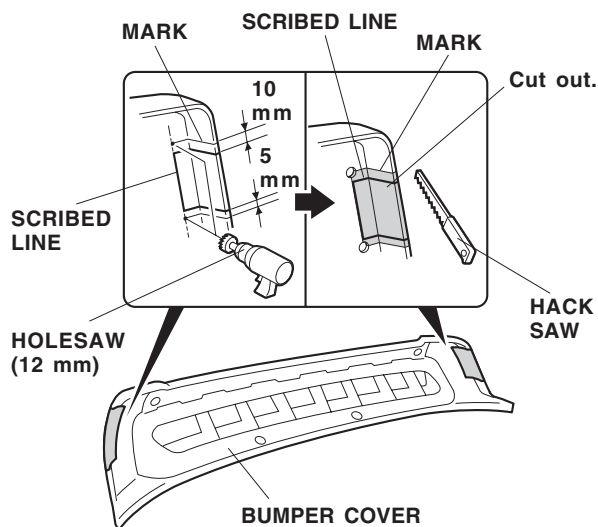

- Using a 12 mm hole saw, drill through the bumper cover at each of the two intersecting points of the marks and scribed lines made in step 5. Repeat on the other side of the bumper cover.
- Using a hacksaw blade, cut out the bumper cover at the marked area. Remove any burrs. Cut the other side of the bumper cover the same way.
- While wearing eye protection, drill a 10 mm hole through the eight marks on the front bumper.
 - First drill with a 3 mm drill bit, then with a 6 mm drill bit, and finish with a 10 mm drill bit.
 - Remove any burrs from the edges of the holes with a file.

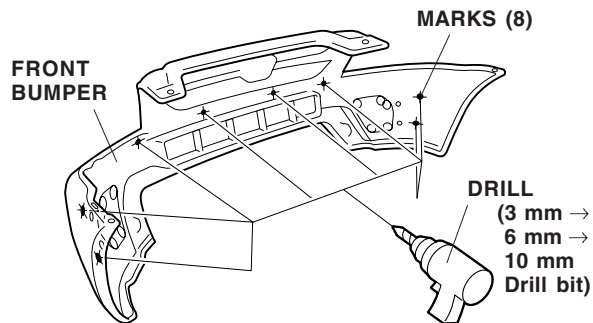

- Reinstall the bumper cover to the front bumper.

10. Align the front lower trim with the front bumper, and install it using eight long stepped bolts.

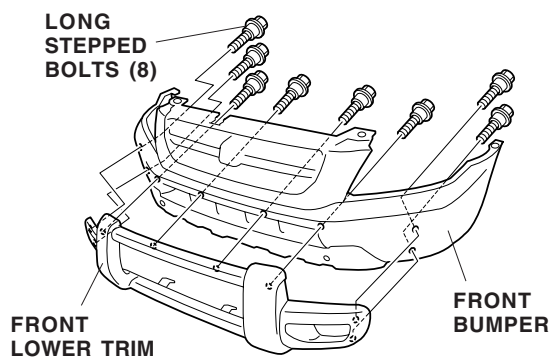

11. Install four short stepped bolts.

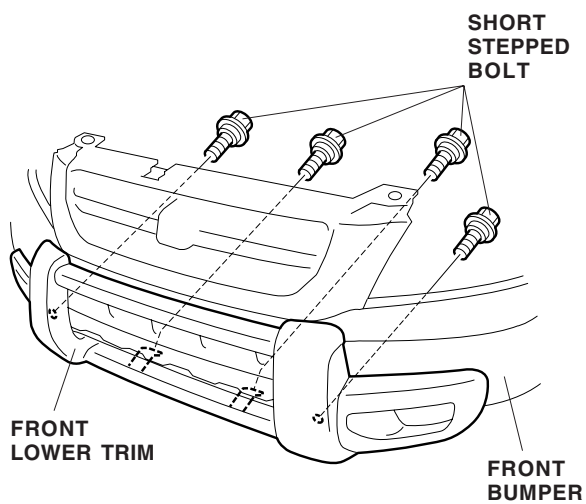

12. Reinstall the front bumper. Make sure that all clips and retaining tabs are attached properly.