



INSTALLATION INSTRUCTIONS

Accessory

**GOLD EMBLEM KIT
P/N 08F20-S9V-100**

Application

2005 PILOT

Publications No.

All 28059

Issue Date

SEP 2004

PARTS LIST

Front gold "H" emblem

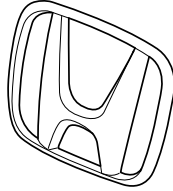

Rear gold "H" emblem

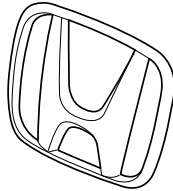

Rear gold "PILOT" emblem

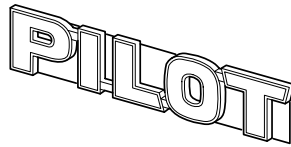

TOOLS AND SUPPLIES REQUIRED

Phillips screwdriver

Flat-tip screwdriver

Ratchet

10 mm Socket

Masking tape

Isopropyl alcohol

Shop towel

String

6 mm Combination wrench

INSTALLATION

Customer Information: The information in this installation instruction is intended for use only by skilled technicians who have the proper tools, equipment, and training to correctly and safely add equipment to your vehicle. These procedures should not be attempted by "do-it-yourselfers."

NOTE :

- Be careful not to damage the body paint finish.
- This gold emblem kit should be installed only if the ambient air temperature is above 60°F (15°C).
- To allow the adhesive to "cure," do not wash the car for 24 hours.

Installing the Front Gold "H" emblem

1. Open the hood. Remove the bulkhead cover (11 clips).

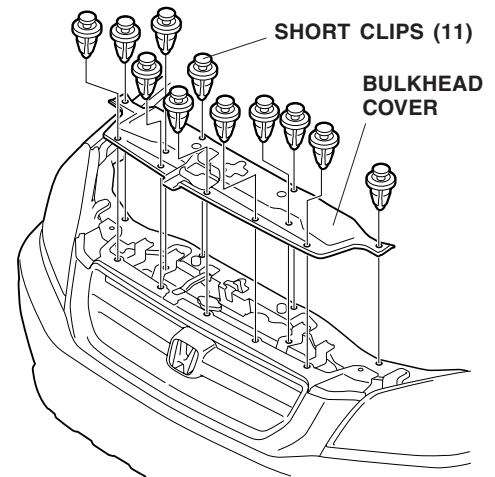

- Remove the two short clips, two self-tapping screws, four bolts, and two long clips that secure the front bumper, then remove the front bumper by pulling it toward you.

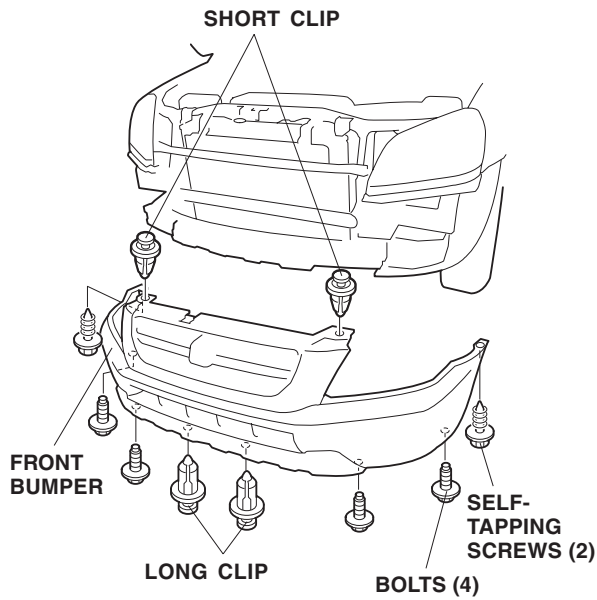

- Remove the front "H" emblem (two self-tapping screws).

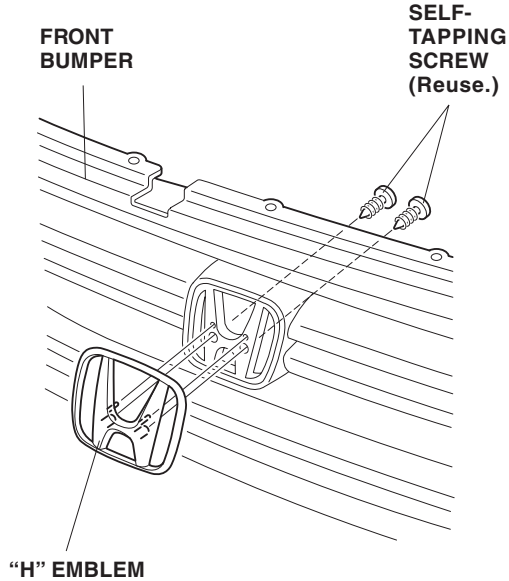

- Using isopropyl alcohol on a shop towel, clean the area where the "H" emblem was removed.
- Attach the gold "H" emblem to the front bumper with the two self-tapping screws you removed.

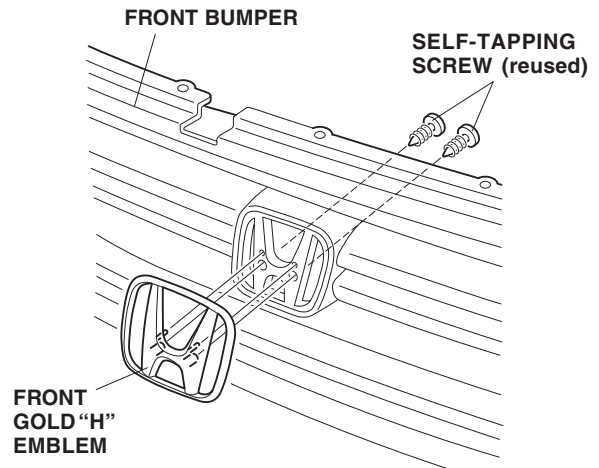

- Reinstall the front bumper. Check that the clips are installed securely.

Installing the Rear Gold "H" Emblem

- Open the tailgate. Remove the tailgate upper trim (two retaining tabs and two clips).

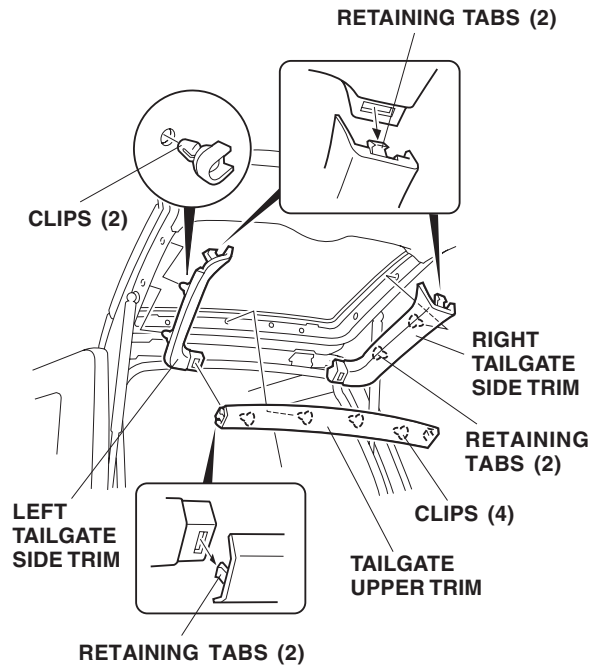

- Release the one retaining tab and two clips. Remove the right and left tailgate side trims (one retaining tab and two clips).

- Remove the two covers from the grab rail, then remove the two screws concealed under the covers. Remove the grab rail.

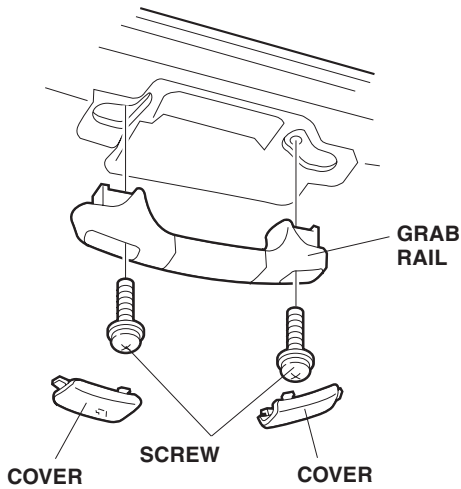

- Remove the tailgate rear trim:
 - Release the two clips that secure the bottom of the tailgate rear trim.
 - Release the 11 clips, and lift the tailgate rear trim up away from the tailgate.
 - Unplug the vehicle connector, and remove the tailgate rear trim.

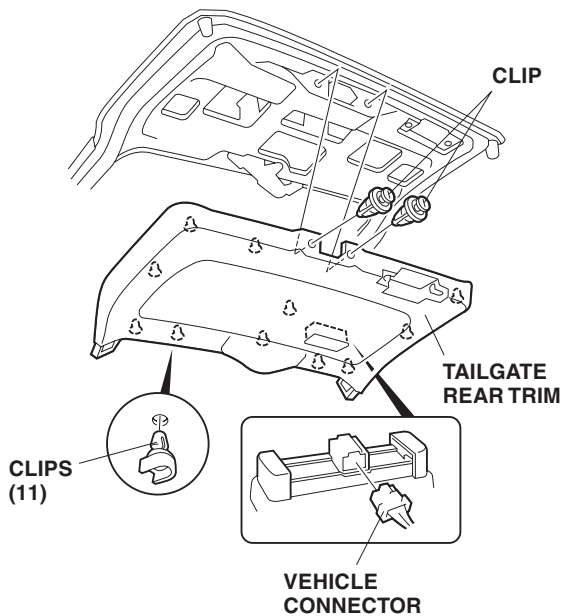

- Disconnect the two connectors from the back-up lights.

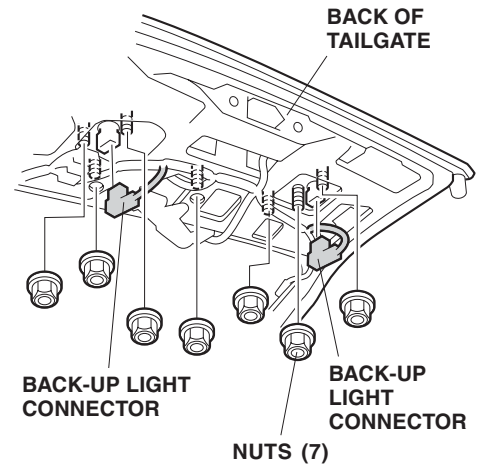

- Remove the seven nuts from the back of the tailgate.
- Release the four clips, and remove the rear license trim. If the clip is hard to remove, use a 6 mm combination wrench to pry three of them loose. Use a clip remover to remove the last clip under the body panel.

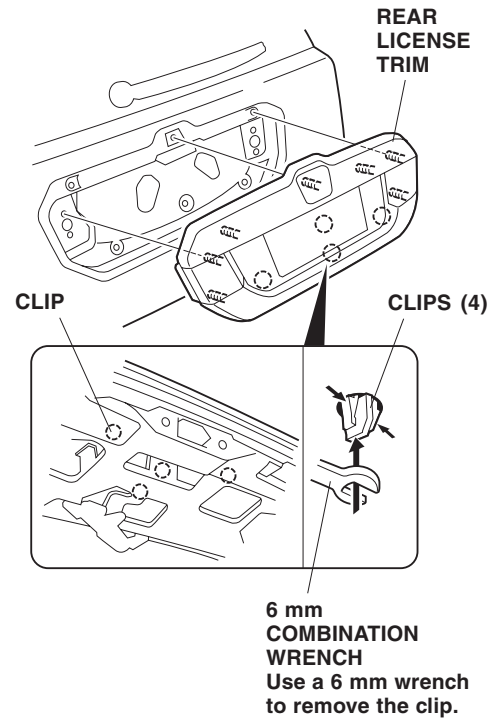

- Remove the "H" emblem from the rear license plate trim (two screws).

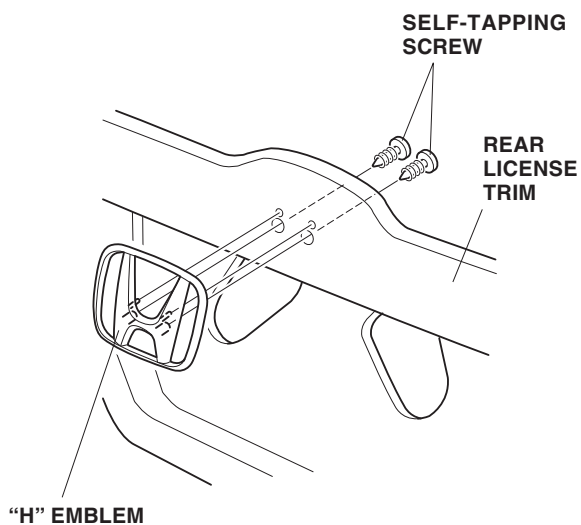

- Using isopropyl alcohol on a shop towel, clean the area where the "H" emblem was removed.
- Attach the gold "H" emblem to the rear license trim with the two self-tapping screws you removed.

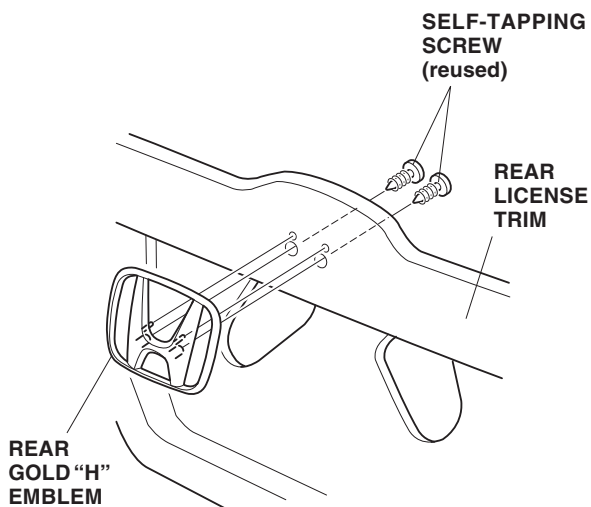

- Reinstall all removed parts.

Installing the Rear Gold "PILOT" Emblem

- Mark the locations of the existing "PILOT" emblem by applying masking tape along the four edges of the emblem.

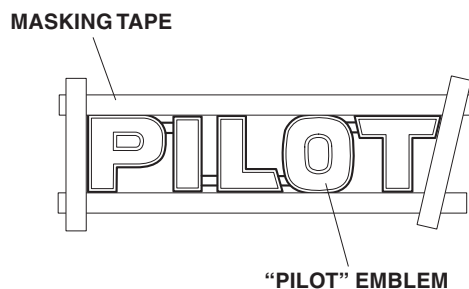

- Remove the original rear emblem by cutting the outer edges with a piece of string.

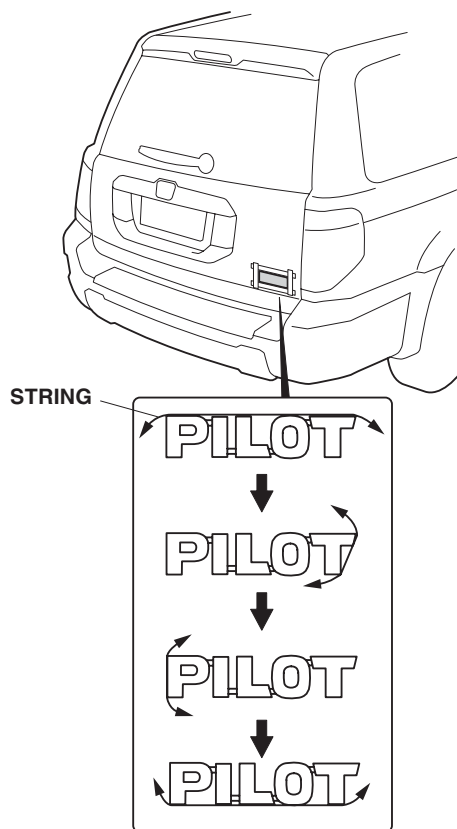

20. Using isopropyl alcohol on a shop towel, clean the area where the emblem was removed.
21. Remove the backing from the gold "PILOT" emblem, and attach the emblem to the tailgate.
22. Press the emblem firmly against the body with the

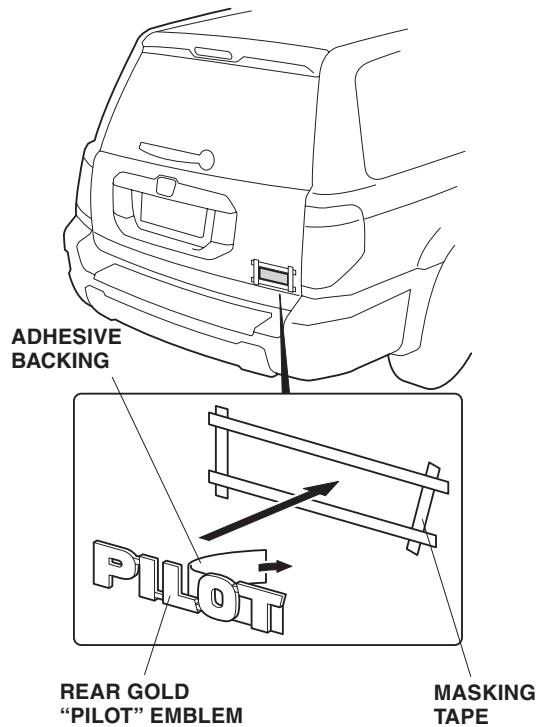

palm of your hand for 30 seconds.

23. Remove the masking tape.

NOTE: After the emblem kit is installed, tell your customer not to wash the vehicle for 24 hours to give the adhesive time to cure.