



INSTALLATION INSTRUCTIONS

Accessory
**FOG LIGHTS
(WITH FRONT BUMPER
LOWER TRIM)**

Application
2005 PILOT

Publications No.
All 28056
Issue Date
SEP 2004

PARTS LIST

Fog Light Kit
P/N 08V31-S9V-100C

Right fog light

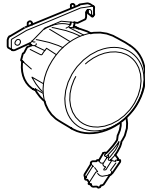

Left fog light

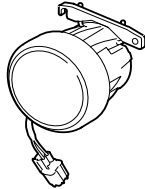

Right fog light bracket

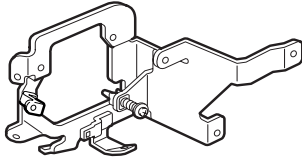

Left fog light bracket

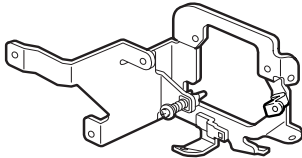

Switch harness

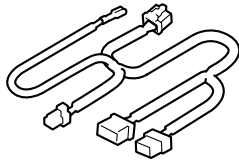

Fog light harness

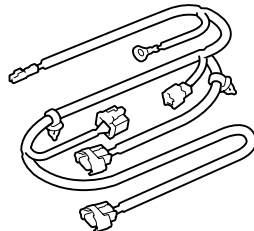

Switch

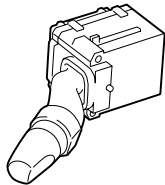

4 Collars



Relay with rubber cover

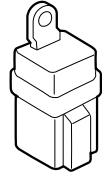

Relay

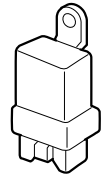

24 Wire ties

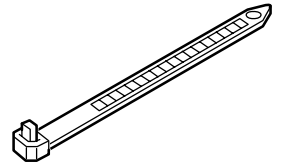

8 Washer-screws, 5 x 16 mm



4 Washer-screws, 4 x 12 mm



2 Washer-bolts



Flange nut



Relay bracket

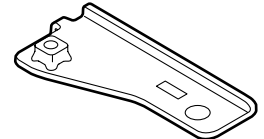

Fuse (20A)

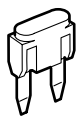

Control unit bracket



Right fog light cover

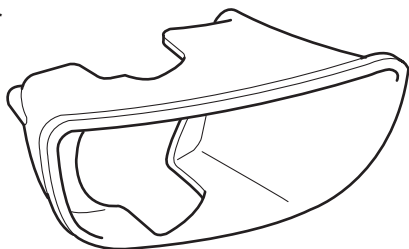

Left fog light cover

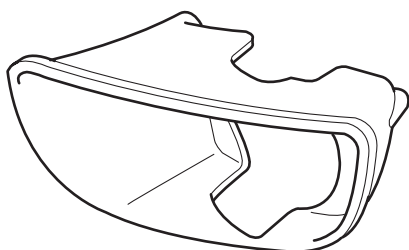

4 Self-tapping screws, 5 x 20 mm



2 Washers



TOOLS AND SUPPLIES REQUIRED

Phillips screwdriver
 Flat-tip screwdriver
 Ratchet
 10 mm and 12 mm Sockets
 Diagonal cutters
 40 mm Hole saw
 Utility knife
 Hacksaw blade
 10 mm Combination wrench
 Cardboard or blanket
 Drill
 3 mm and 9 mm Drill bits
 Torque wrench
 Pushpin
 File
 Ruler
 Felt-tip pen
 Clip remover

Illustration of Fog Lights Installed on the Vehicle

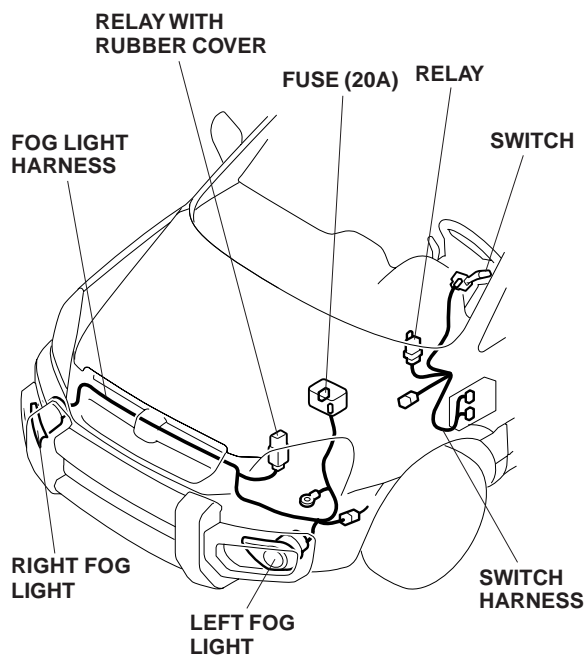

INSTALLATION

Customer Information: The information in this installation instruction is intended for use only by skilled technicians who have the proper tools, equipment, and training to correctly and safely add equipment to your vehicle. These procedures should not be attempted by "do-it-yourselfers."

1. Make sure you have the anti-theft code for the radio, then write down the radio station presets.
2. Disconnect the negative cable from the battery.

Routing the Fog Light Harness

3. Open the hood. Remove the bulkhead cover (11 clips).

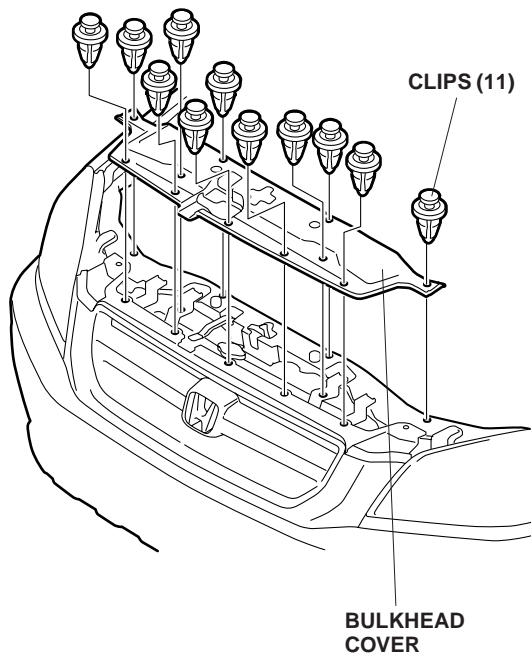

4. Remove the front bumper (two short clips, two self-tapping screws, four bolts, and two long clips).

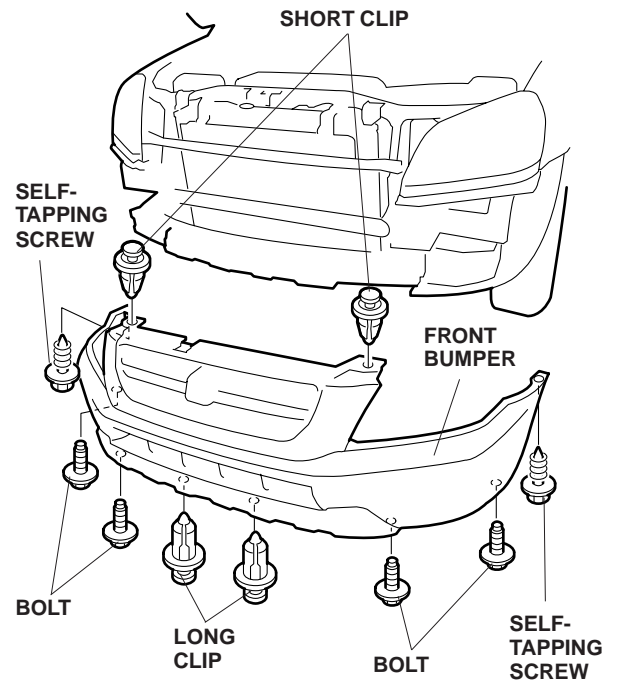

5. Remove the tube from the air cleaner case.

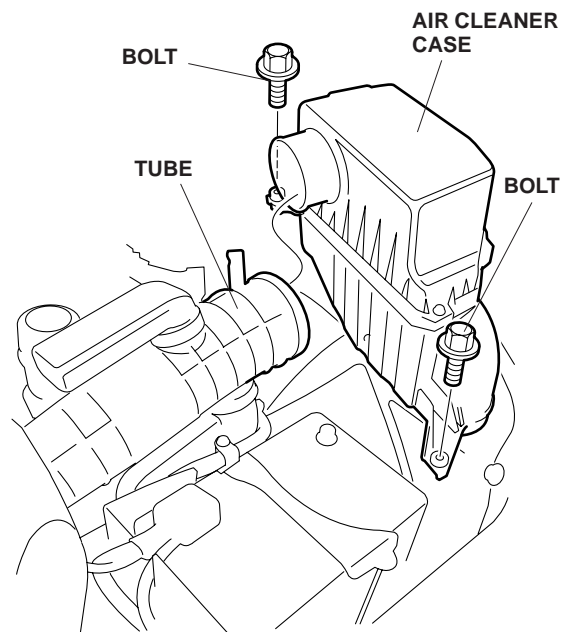

6. Remove the air cleaner case (2 bolts). Be careful not to damage the vehicle harness.

7. Remove the subfuse box from the stay (one tab).

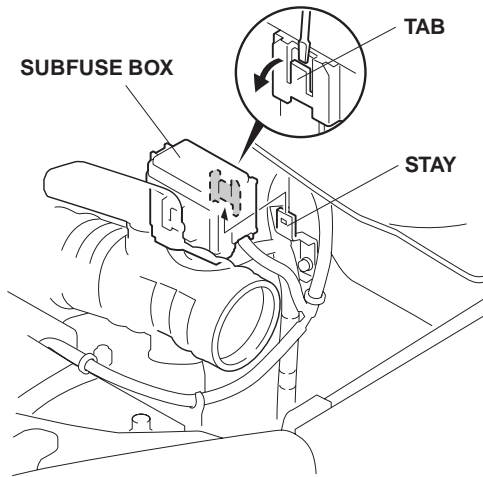

8. Turn the subfuse box upside down and remove the subfuse box under cover (4 tabs).

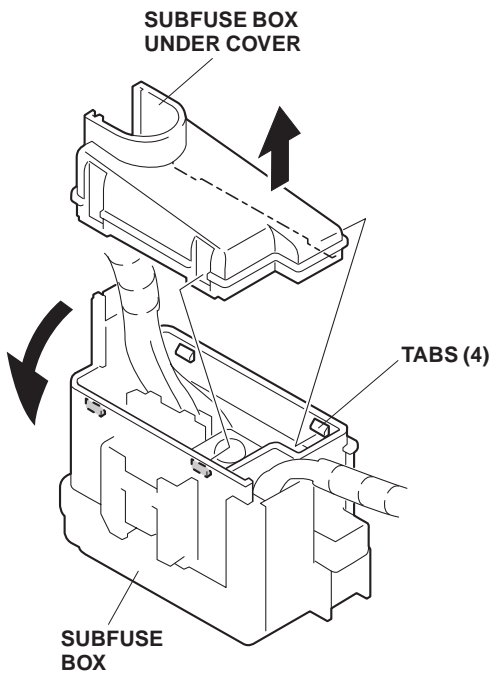

9. Insert the fog light harness terminal into the slot of the subfuse box.

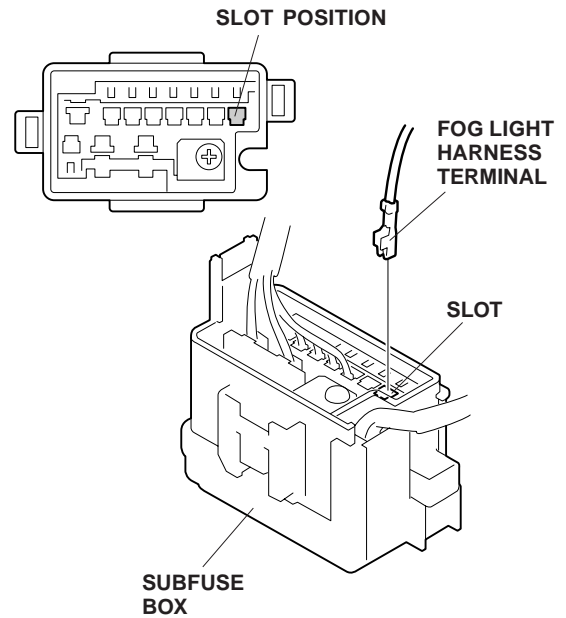

10. Route the fog light harness along the vehicle harness and reinstall the subfuse box under cover.

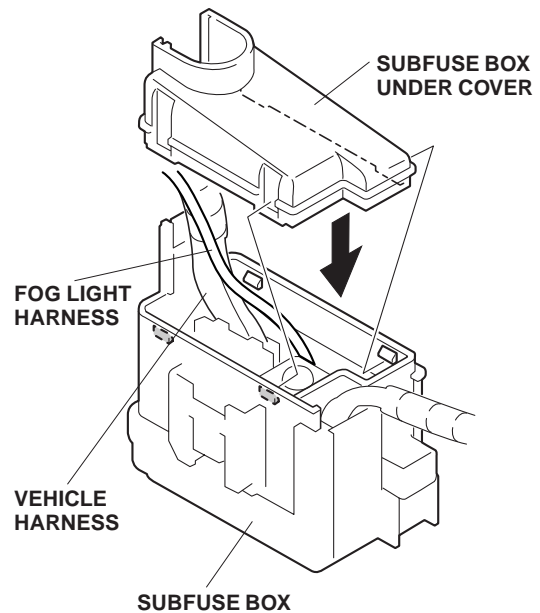

11. Reinstall the subfuse box.

- Remove the subfuse box cover and insert the fuse (20A) into the subfuse box.

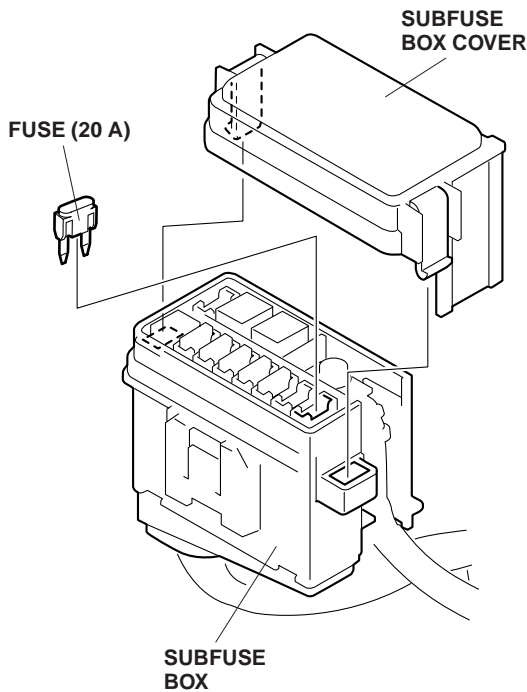

- Route the fog light harness along the vehicle harness towards the front of the vehicle. Remove the vehicle ground bolt and attach the fog light harness ground terminal to the vehicle ground terminal. Tighten the vehicle ground bolt.

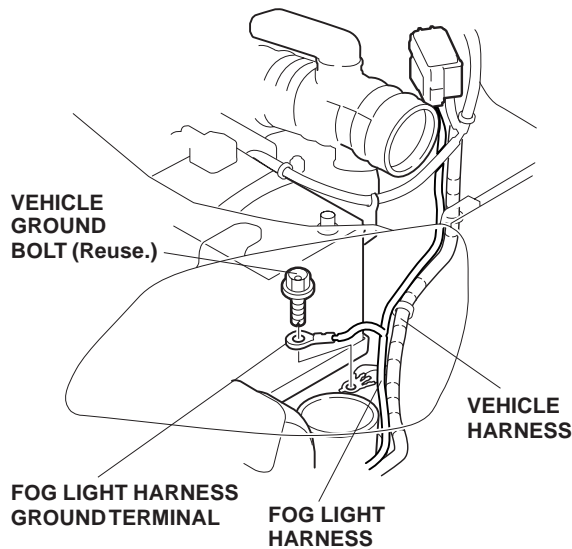

- Pull the short end of the fog light harness 2-pin connector out from under the left headlight. Under the left headlight, locate the 1-pin connector blue-taped to the vehicle harness. Remove the blue tape to free the connector. Plug the vehicle 1-pin connector into the fog light harness 1-pin connector.

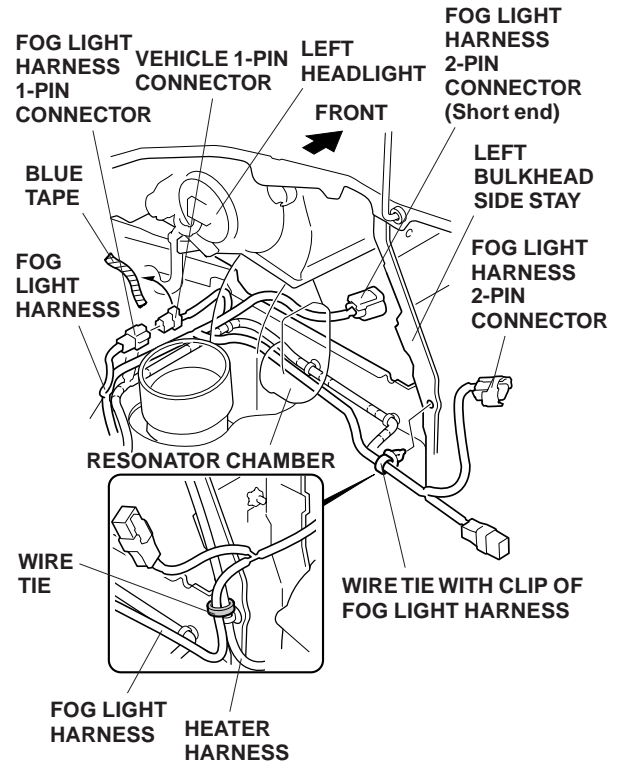

- Route the other fog light harness 2-pin connector in front of the resonator chamber and secure the wire tie with clip from the fog light harness into the hole in the left bulkhead side stay. If an engine block heater is installed, align the wire tie with clip from the fog light harness with the position of the wire tie attaching the heater harness, and secure the fog light harness to the heater harness with the wire tie.

- Secure the remaining wire tie with clip from the fog light harness into the hole in the left front bulkhead panel.

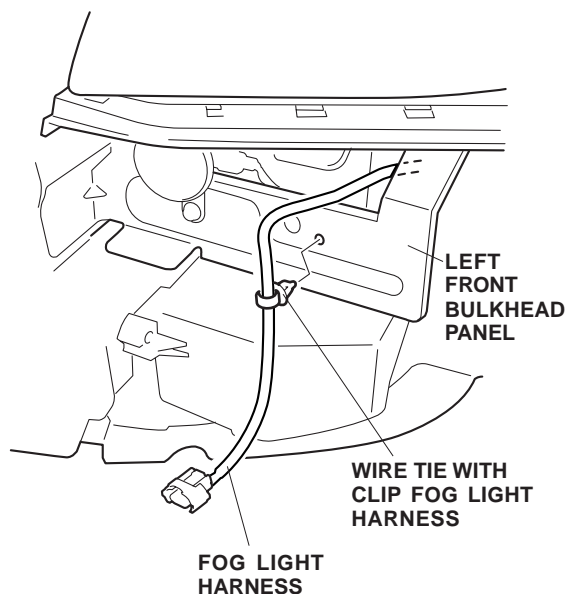

- Route the fog light harness alongside the vehicle harness and above the fan shroud toward the right (passenger's) side of the vehicle.

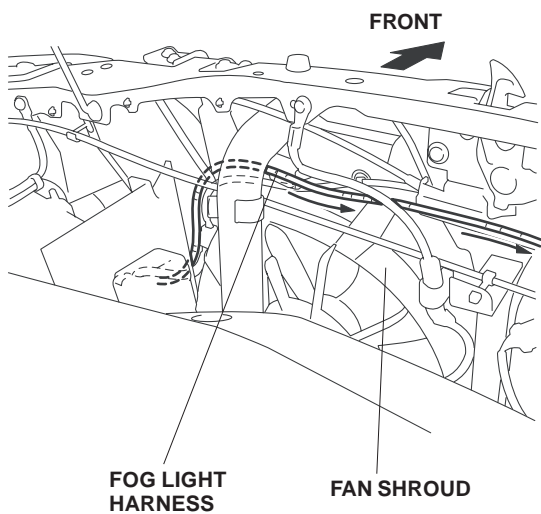

- Continue routing the fog light harness under the vehicle harness to the right side of the vehicle, then pull the harness out from under the right headlight through the opening near the right horn.

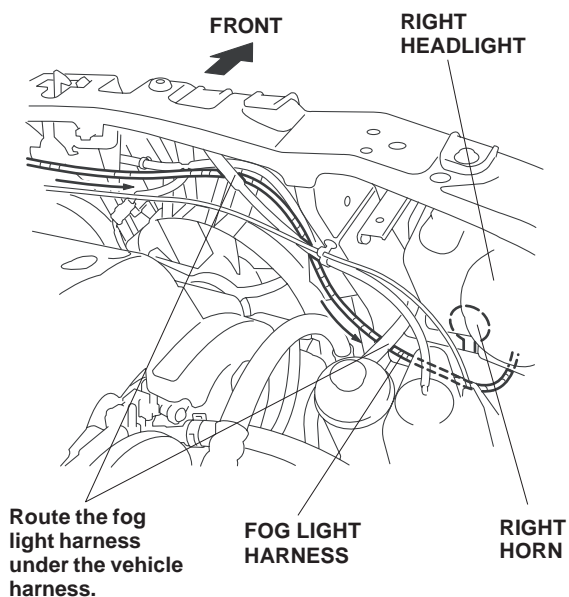

- Secure the fog light harness to the vehicle harness with two wire ties.

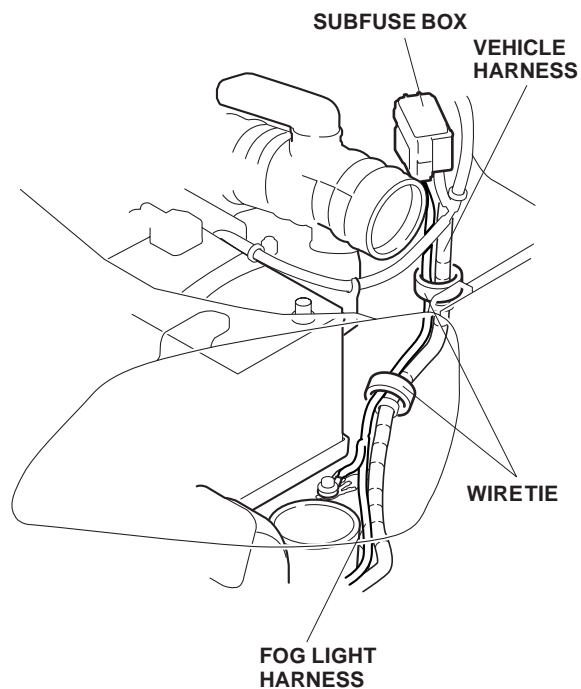

20. Near the left headlight secure the fog light harness to the vehicle harness with two wire ties.

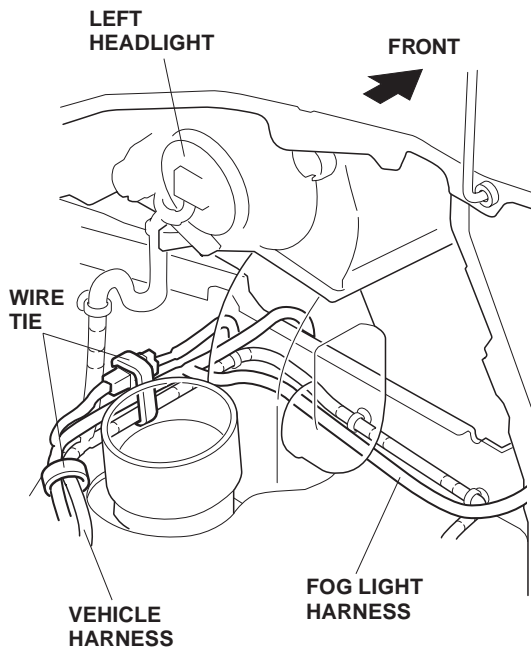

21. At the left front bulkhead panel secure the fog light harness to the vehicle harness with two wire ties.

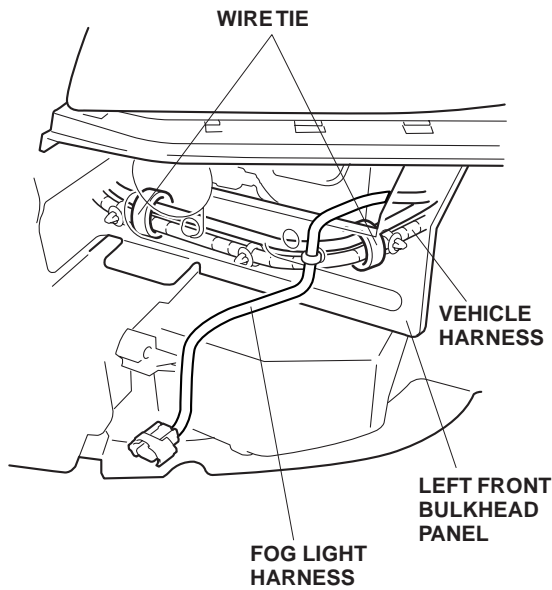

22. Above the left fan shroud secure the fog light harness to the vehicle harness with the two wire ties.

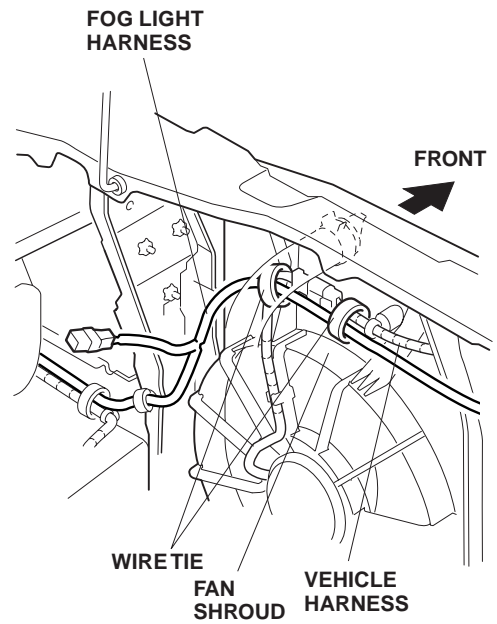

23. Above the right fan shroud, secure the fog light harness to the vehicle harness with five wire ties.

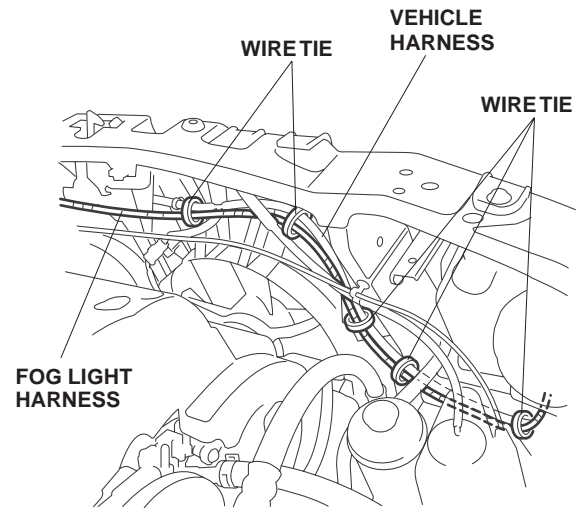

24. Below the right headlight, secure the fog light harness to the vehicle harness with two wire ties.

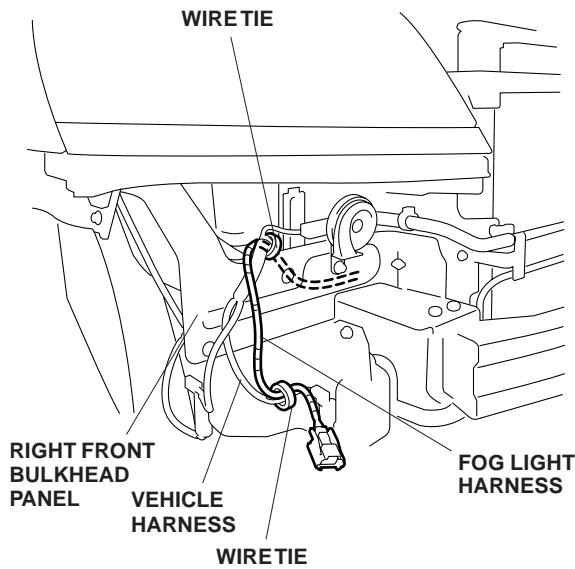

Installing the Relay with Rubber Cover

25. Remove the vehicle bolt from the left bulkhead side stay.

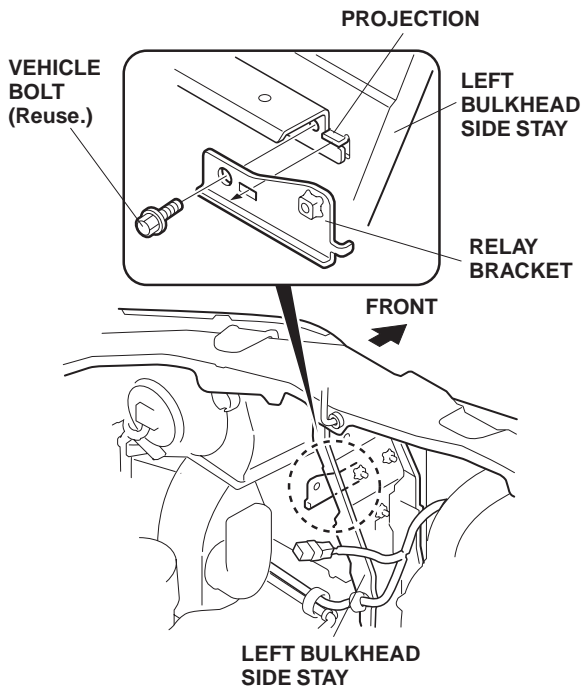

26. Align the projection from the left bulkhead side stay with the hole in the relay bracket and install the relay bracket to the left bulkhead side stay with the vehicle bolt you removed.

27. Plug the fog light harness 4-pin connector into the relay with rubber cover and install the relay with rubber cover to the relay bracket with one washer-bolt.

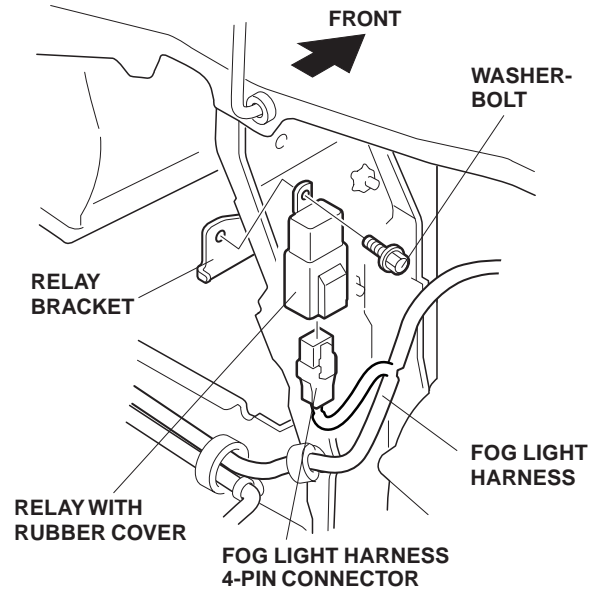

Installing the Fog Lights

28. If equipped, remove the front bumper lower trim. If you are installing a front bumper lower trim, refer to the front bumper lower trim installation instructions before drilling the front bumper.
29. On the inside of the front bumper, locate the seven preset marks for the fog light. Use a pushpin to make holes through the front bumper at each of the seven marks.

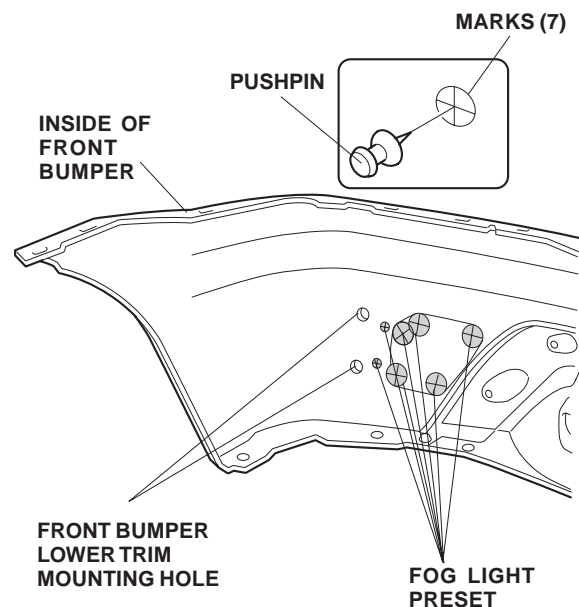

30. While wearing eye protection, drill a 9 mm through each of the two outboard marks you made. Drill from the outer surface inward, first with a 3 mm drill bit, and finish with a 9 mm drill bit. Remove any burrs from the edges of the holes with a file.

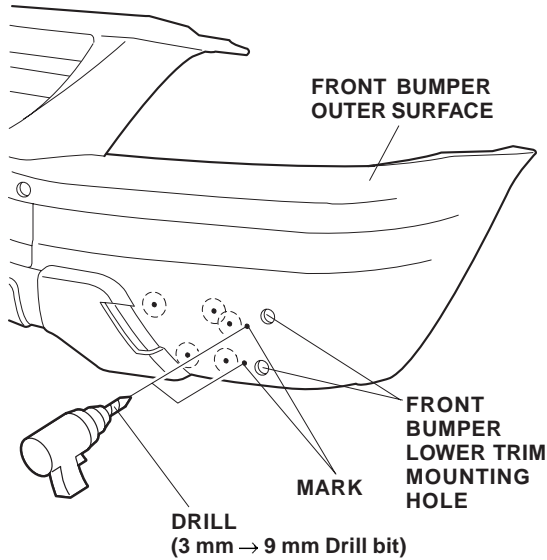

31. Using a 40 mm hole saw, drill through each of the five remaining marks in the front bumper.

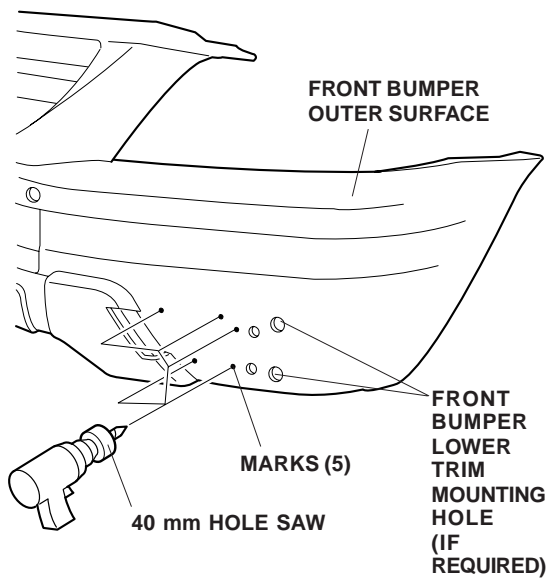

32. On the inside of the front bumper, use a ruler and felt-tip pen to make a line between the corners of the five holes. Using a hacksaw blade, cut out the marked area from the front bumper along the lines. Remove any burrs from the edge of the holes.

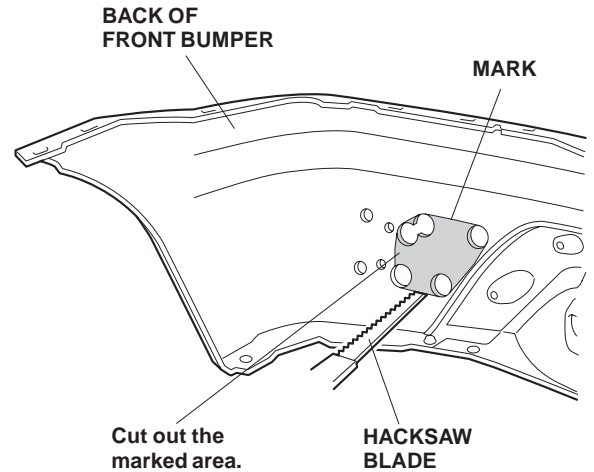

33. Get the left fog light and the left fog light bracket. Insert the slot on the left fog light into the aiming adjusting screw, then install the two 5 x 16 mm washer-screws.

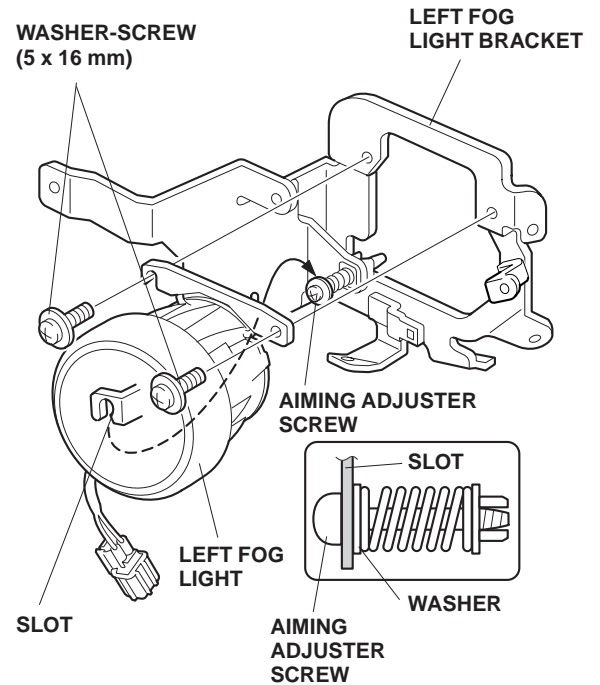

34. On the inside of the front bumper near the hole you cut, remove and discard the two self-tapping screws from the bumper. Position the left fog light bracket on the left mounting bosses, and install two 5 x 20 mm self-tapping screws and one washer to hold the fog light bracket.

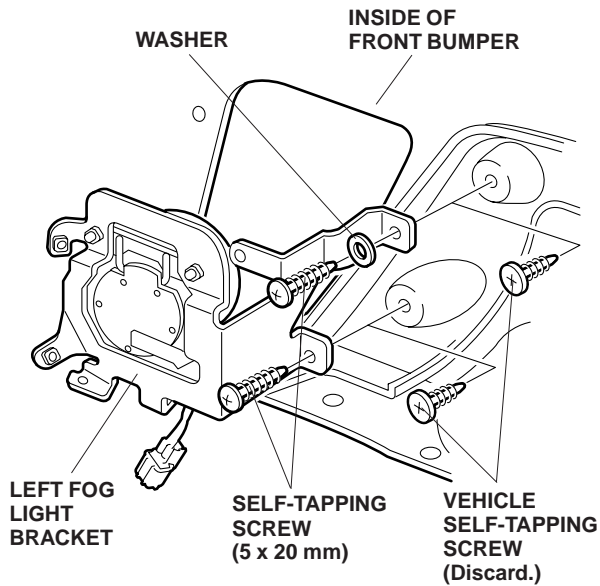

35. Position the left fog light bracket against the front bumper, and install two 5 x 16 mm washer-screws and two collars from the front of the bumper.

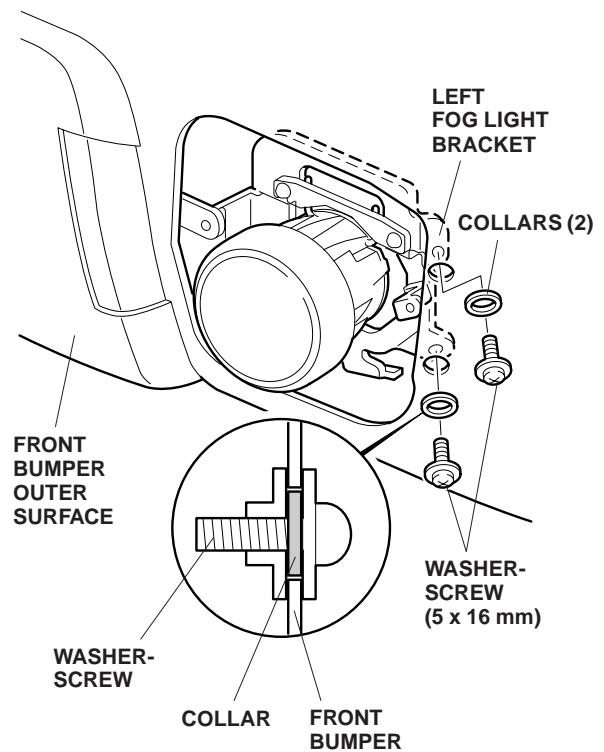

36. Repeat steps 29 through 35 to install the right fog light onto the right fog light bracket at the right side of the front bumper.
37. Reinstall the front bumper lower trim. (Refer to the front bumper lower trim installation instructions to install the front bumper lower trim.)

38. While holding the front bumper close to the vehicle, connect the 2-pin connectors of the fog light harness to the right and left fog lights, then reinstall the front bumper. Make sure that all clips and retaining tabs are installed securely.

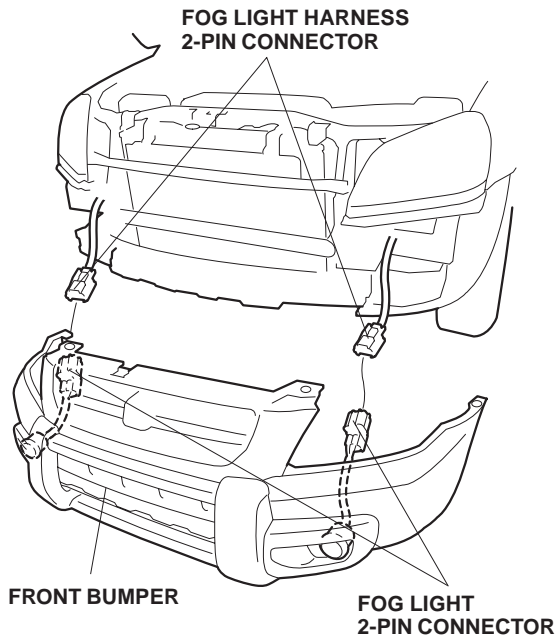

39. On each side, pull the 2-pin connectors out from between the fog light brackets, and slide the 2-pin connectors onto the fog light bracket stays.

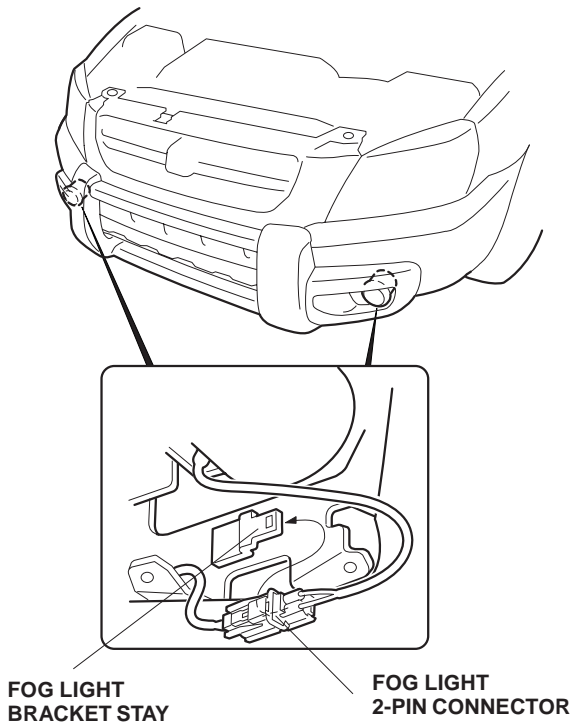

Routing the Switch Harness

40. Remove the fuel lid door opener knob.

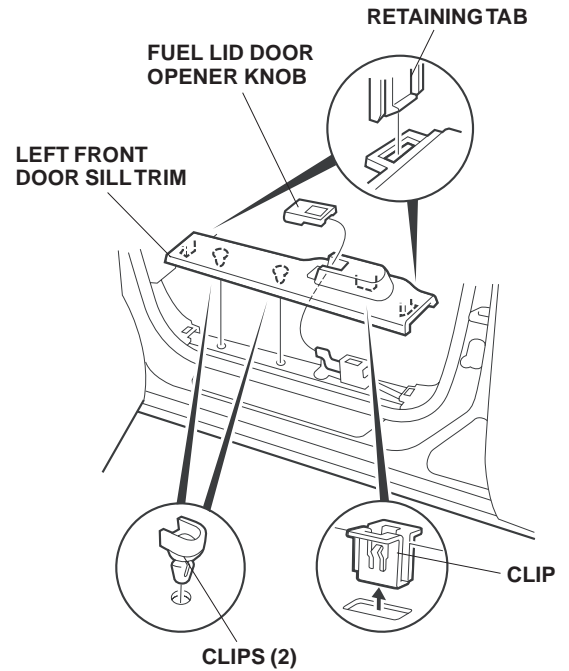

41. Remove the left front door sill trim (three clips and two retaining tabs).
42. Remove the weatherstrip from the left kick panel.

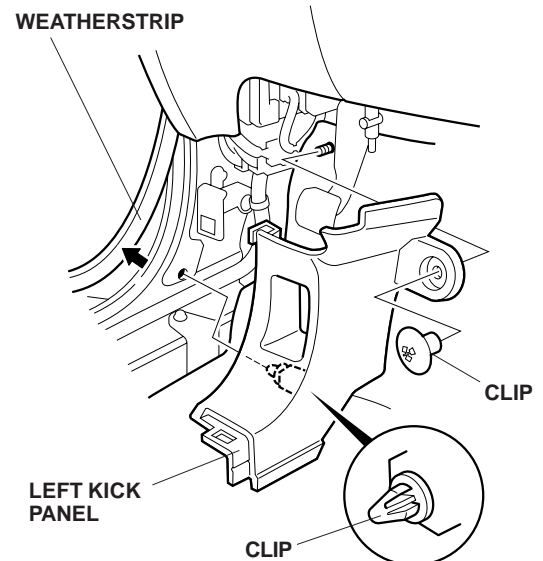

43. Remove the upper clip from the left kick panel, then pull the left kick panel out toward you to release the remaining clip.

44. Remove the driver's dashboard lower cover (one self-tapping screw, three clips, and two hooks).

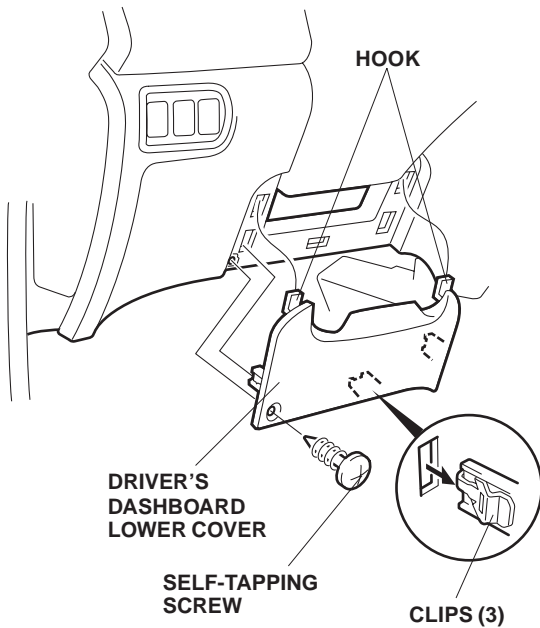

45. Lower the steering wheel using the tilt lever, then remove the upper and lower steering column covers (two washer-self-tapping screws and one screw).

- Carefully pry up on the seven retaining tabs to remove the lower steering column cover.
- Insert the ignition key in the shift lock release hole, and move the shift lever to the "N" position while pressing down on the key.
- Remove the key, then lift the upper steering column cover. Pull the cover out toward you, and remove it by lowering the shift lever to the "1" position.

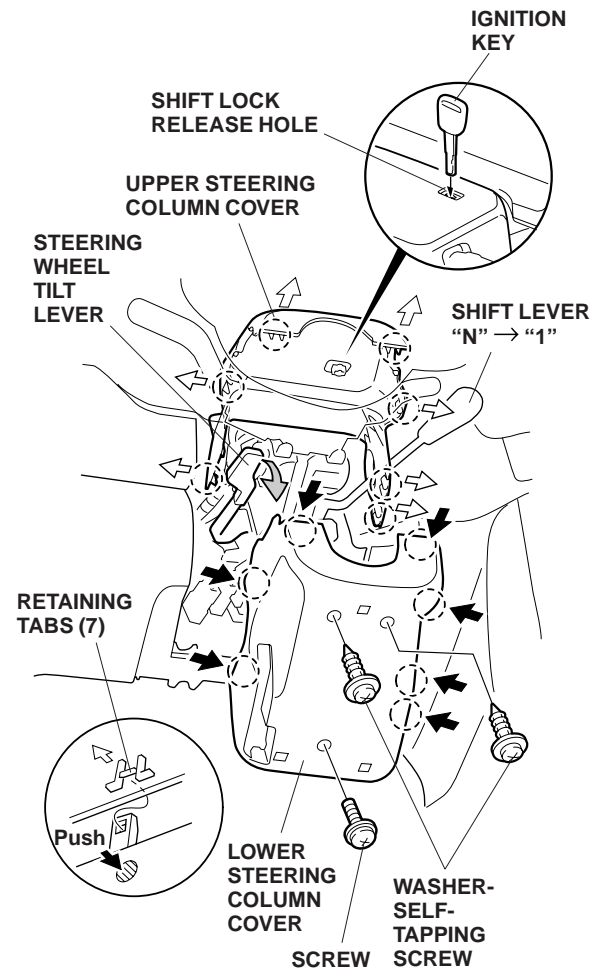

46. Get the switch harness. Plug the two 6-pin connectors from the switch harness into the two 6-pin connectors on the fuse box.

Without Automatic Day/Night Mirror:

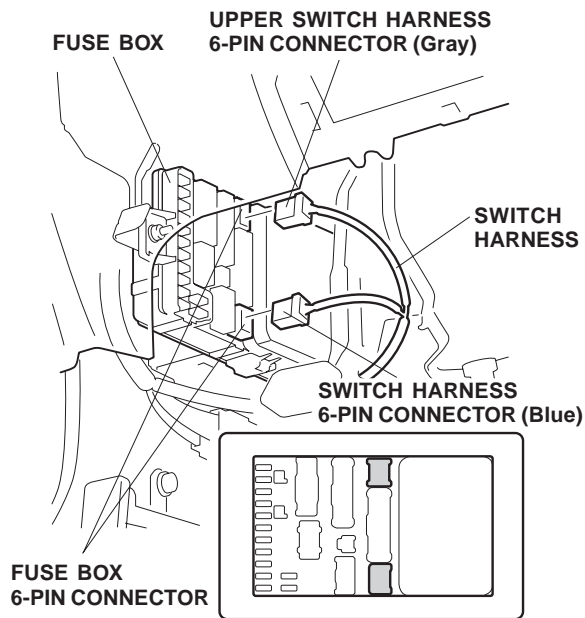

With Automatic Day/Night Mirror:

If you are also installing an accessory, connect the 6-pin connectors from the automatic day/night mirror between the upper switch harness 6-pin (gray) connector (gray) and the fuse box.

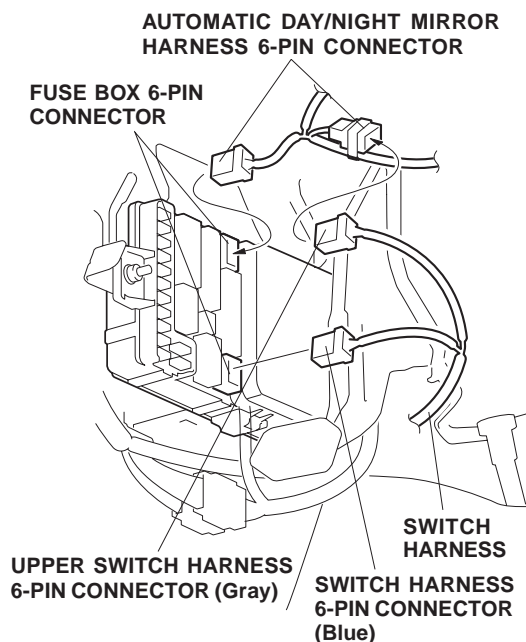

47. Route the switch harness 2-pin connector along the vehicle harness near the parking brake bracket, and locate the 2-pin connector blue-taped to the vehicle harness. Remove the blue tape and plug the switch harness 2-pin connector into the vehicle harness 2-pin connector.

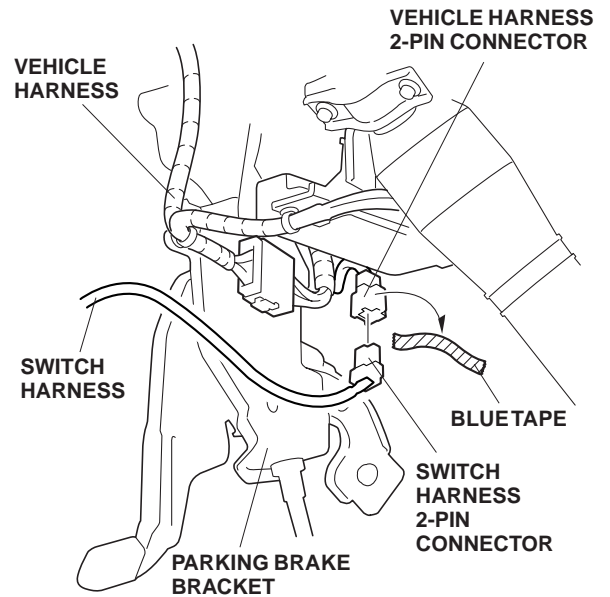

48. Get the relay and the control unit bracket. Position the relay on the control unit bracket, and install the washer-bolt and flange nut.

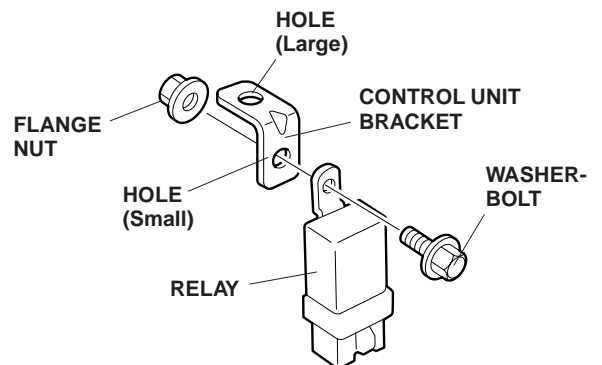

49. Plug the switch harness 4-pin connector into the relay .

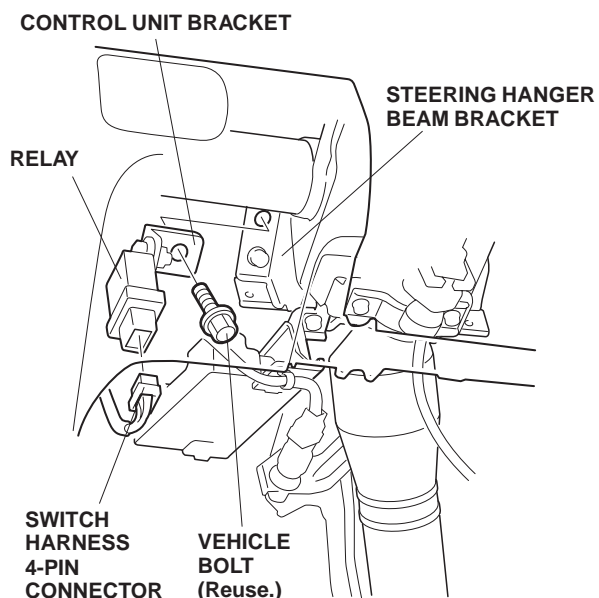

50. Remove the vehicle bolt that secures the steering hanger beam bracket, and attach the control unit bracket with this bolt. Torque the steering hanger bracket bolt to 19 to 24 N·m (14 to 18 lb-ft).

51. Unplug the vehicle 16-pin connector from the combination light switch.

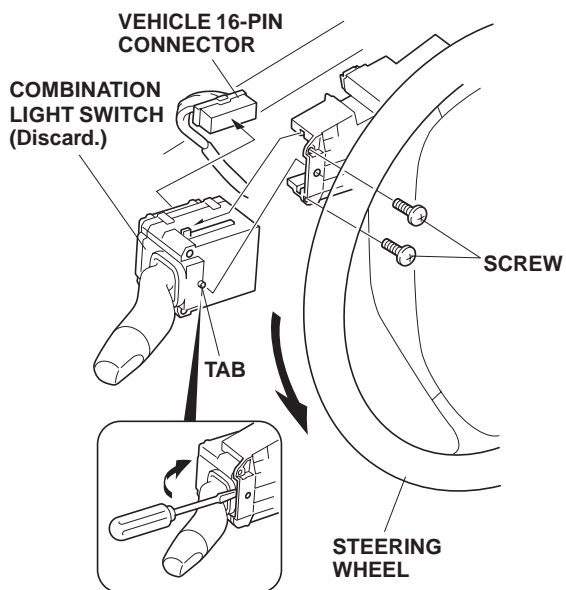

52. Turn the steering wheel in the counterclockwise direction, remove the two screws, disengage the tab of the combination light switch and pull the switch out.

53. Release the locking retainer from the switch harness 16-pin connector and insert the switch harness terminal into the indicated slot of the vehicle 16-pin connector.

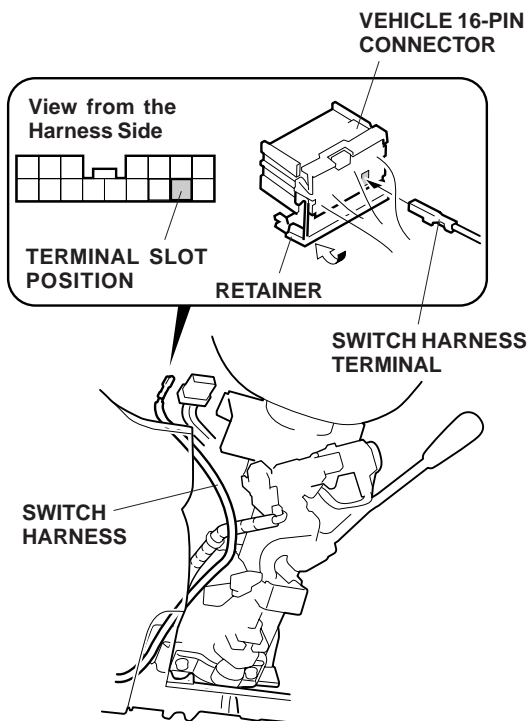

54. Slide the switch onto the steering column and secure the switch with the two screws removed in step 52. Hold the switch case against the column while tightening the screws. Push on the lever.

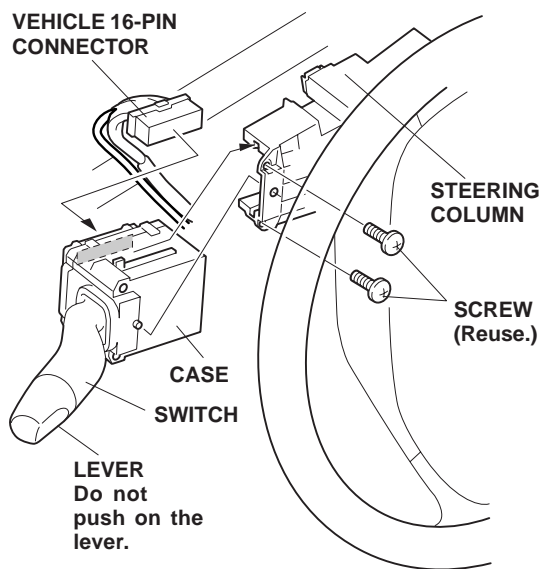

55. Plug the vehicle 16-pin connector into the switch.

56. Secure the switch harness to the vehicle harness with two wire ties.

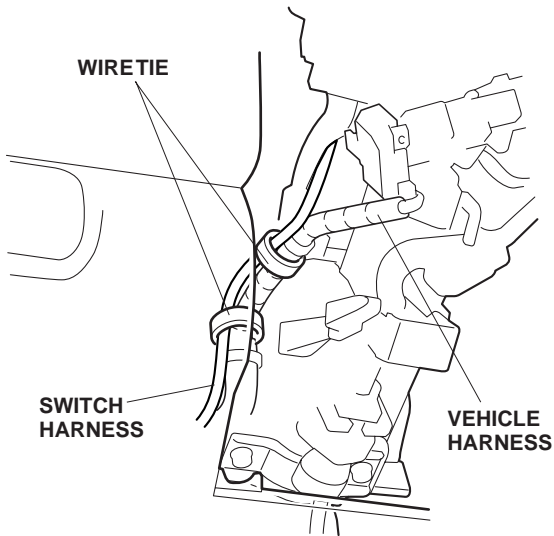

57. Slide the vehicle harness 2-pin connector onto the vehicle connector holder. Secure the switch harness to the vehicle harness with one wire tie in the area shown.

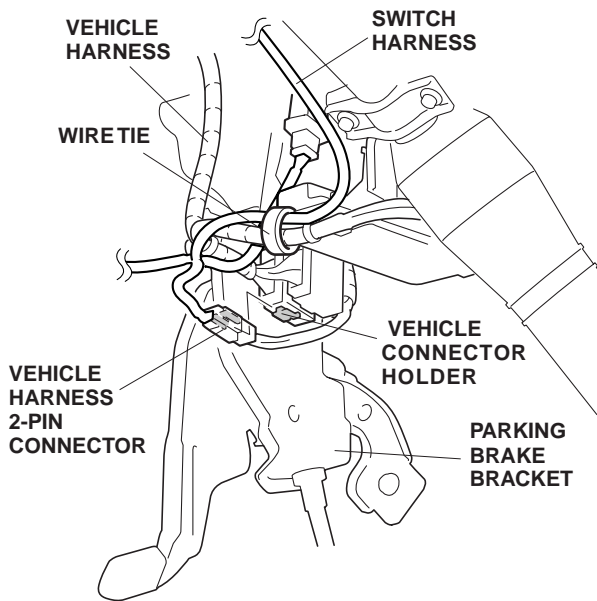

58. Continue to secure the switch harness to the vehicle harness with four additional wire ties in the areas shown.

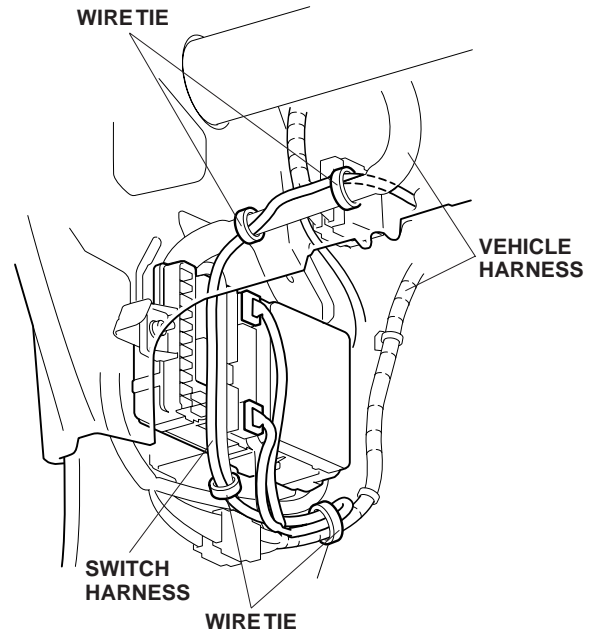

Adjusting the Fog Light Aiming

59. Adjust the fog light:

- Adjust the aiming according to local laws and regulations.
- To adjust, turn the aiming adjustment screw in or out until the correct aiming is obtained.

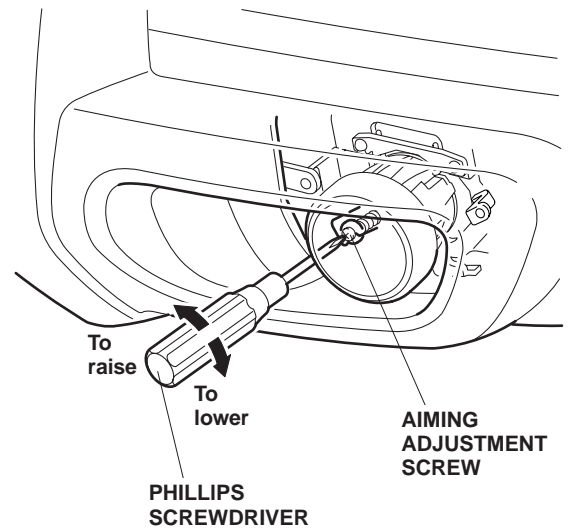

60. Check that all wire harnesses are routed properly and all connectors are plugged in.
61. Reinstall all removed parts. Check that all clips and other fasteners are installed securely.
62. Reconnect the negative cable to the battery.
63. Reset the clock, and reset the radio station presets.

NOTE: Whenever the battery is disconnected, the driver's window AUTO function is disabled.

64. Start the engine. Push down on the driver's window switch until the window is fully open.
65. Pull up on the driver's window switch to close the window completely, then hold the switch for 2 seconds.
66. Lower and raise the window to check the operation of driver's window AUTO function.

Installing the Fog Light Cover

67. Fit the left fog light cover into place on the front lower trim and install the two 4 x 12 mm washer-screws. Repeat on the right side.

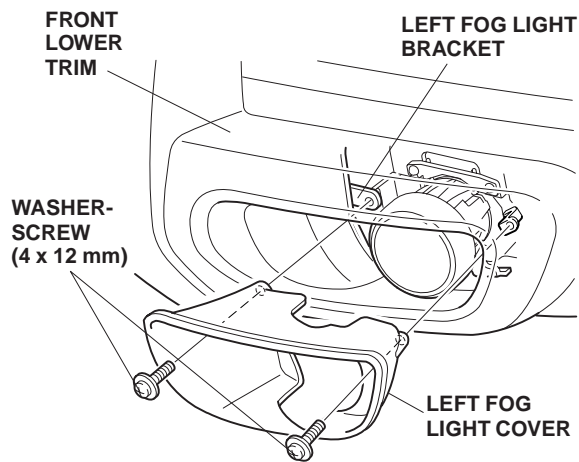

USE AND CARE

How to Operate Fog Lights

- Turn the light switch to the "D" position (headlights on low beam).
- Turn the fog light switch to the "ON" position.

The fog light lenses can cloud when the outside temperature is cold; this is normal and should go away in warm weather.

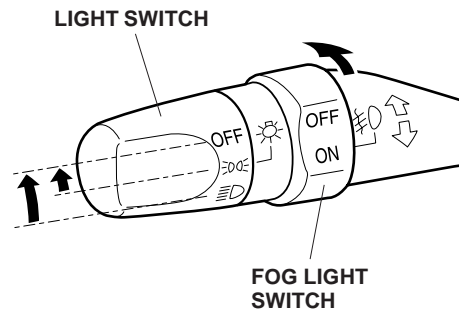

Replacing the Fog Light Bulb

1. Remove the left fog light cover (two screws).

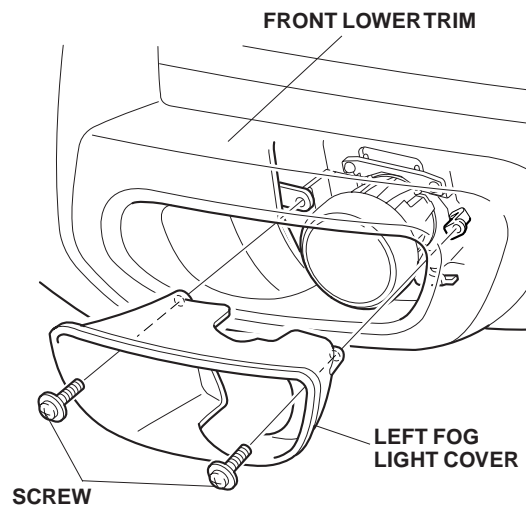

2. Remove the left fog light connector from the connector stay, and unplug the connector.

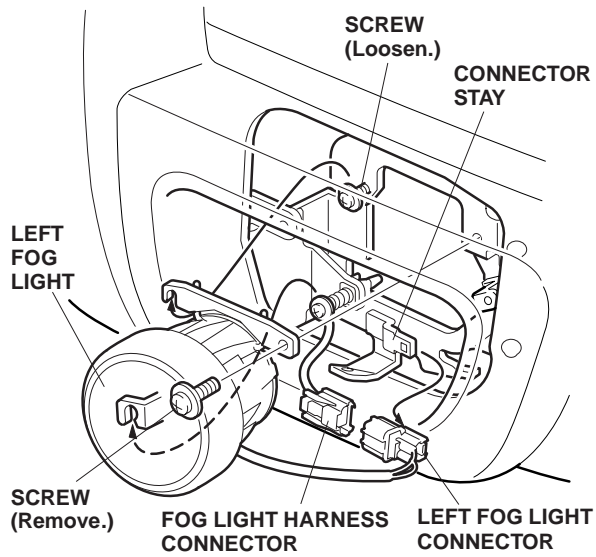

3. Loosen the slotted screw, remove the other screw and remove the left fog light.
4. Remove the rear cover from the left fog light (five screws).

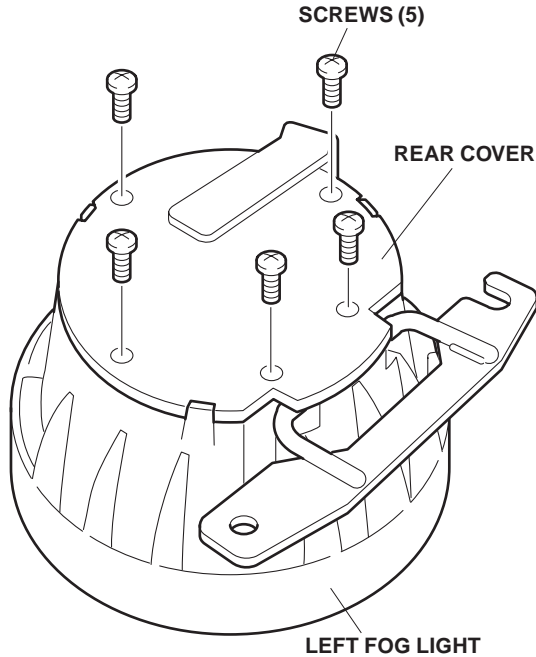

5. Remove the retainer spring, and pull out the bulb and socket as a unit. Replace the bulb with a new one.

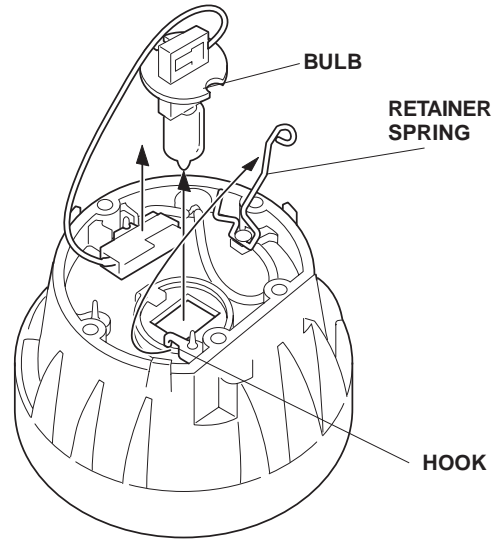

6. Install the new bulb into the socket.

- Use only a genuine Honda halogen light bulb of specified wattage.

Rating: 12V 55W H3 Halogen Light Bulb
P/N 33165-SB0-731-M1

- Do not touch the bulb. Oily or greasy substances on the bulb can shorten its service life due to the heat produced when the bulb is turned on. If the bulb is accidentally touched, wipe it clean with a soft cloth that has been dampened with denatured alcohol or a mild detergent solution.
- Align the tab on the fog light with the cutout in the bulb when installing the new bulb. If not aligned, the fog light may annoy oncoming drivers.

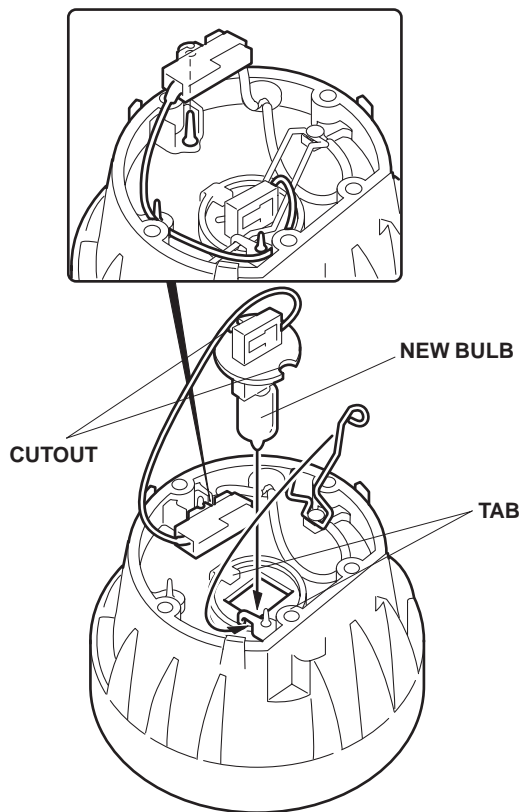

7. Reinstall the removed parts in the reverse order of removal.

- Check that the wire harnesses are not pinched.
- Make sure you tighten all of the screws securely.

CIRCUIT DIAGRAM

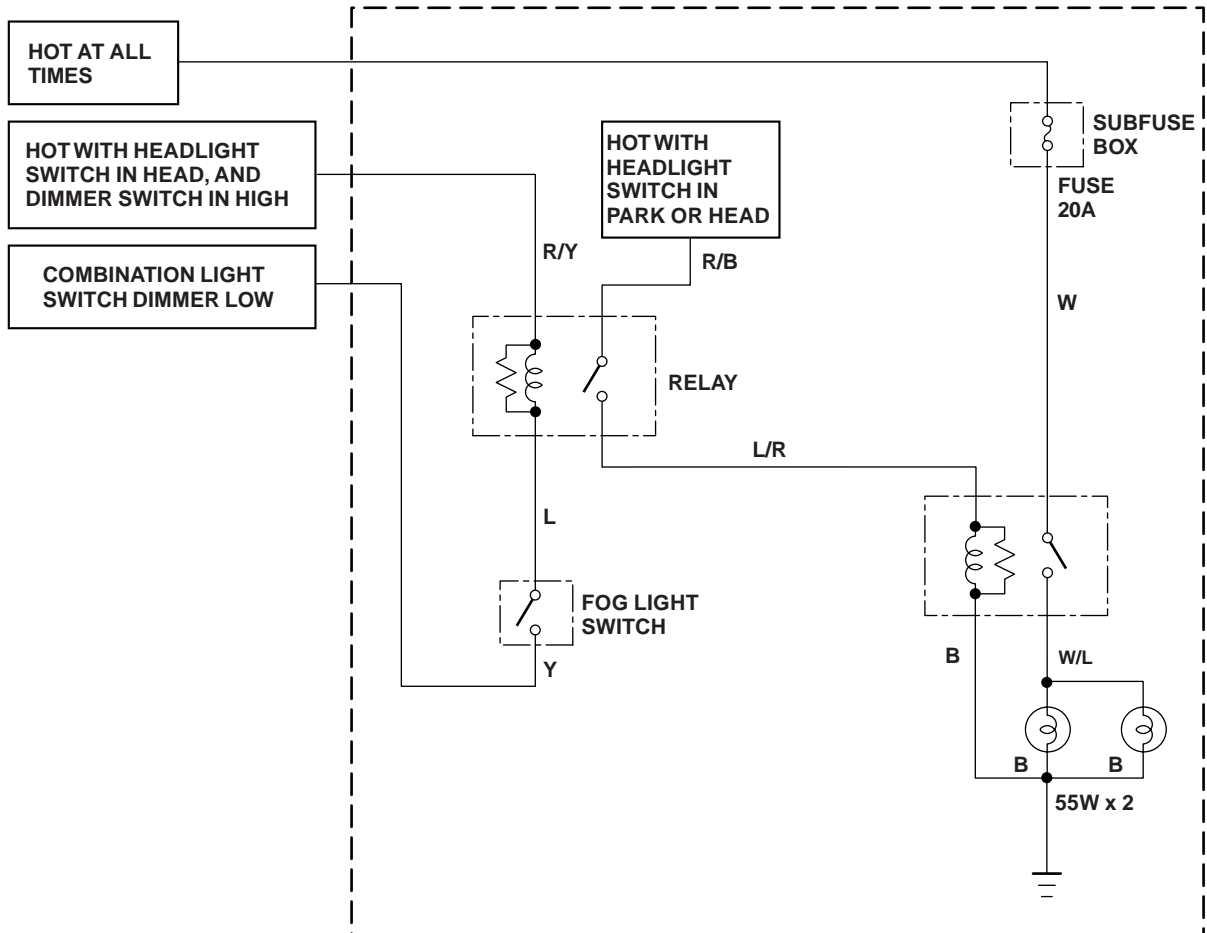

LIGHT SWITCH		LIGHT SWITCH			
		OFF			
FOG LIGHT SWITCH				Low	Hi
FOG LIGHT SWITCH	OFF	—	—	—	—
	ON	—	—	ON	—

B	BLACK	BR	BROWN
Y	YELLOW	O	ORANGE
L	BLUE	SB	SKY BLUE
G	GREEN	LG	LIGHT GREEN
R	RED	P	PINK
W	WHITE	GR	GRAY