



# INSTALLATION INSTRUCTIONS

Accessory  
**BUMPER TRIM,  
FRONT AND REAR**  
P/N 08F23-S9V-100

Application  
**2005 PILOT**

Publications No.  
**All 28044**

Issue Date  
**SEP 2004**

## PARTS LIST

Left front trim piece



Right front trim piece



Left rear trim piece



Right rear trim piece



12 Brackets

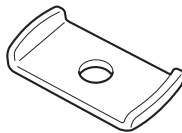

12 Flange nuts



## TOOLS AND SUPPLIES REQUIRED

Phillips screwdriver  
Flat-tip screwdriver  
Ratchet  
10 mm Socket  
Drill  
3 mm and 6 mm Drill bits  
28 mm Hole saw  
Center punch  
File  
Torque wrench  
Masking tape  
Isopropyl alcohol  
Shop towel  
Blanket

## INSTALLATION

**Customer Information:** The information in this installation instruction is intended for use only by skilled technicians who have the proper tools, equipment, and training to correctly and safely add equipment to your vehicle. These procedures should not be attempted by "do-it-yourselfers."

### NOTE:

- An optional full nose mask cannot be used after the chrome bumper trim pieces are installed.
- Be careful not to damage the body paint finish.
- To prevent damage, rest the front bumper on a blanket during the installation.
- This bumper trim pieces should only be installed if the ambient air temperature is above 60 °F (15 °C).
- To allow the adhesive to cure, do not wash the vehicle for 24 hours.

### Installing the Front Bumper Trim Pieces

1. Open the hood. Remove the front bulkhead cover (11 clips).

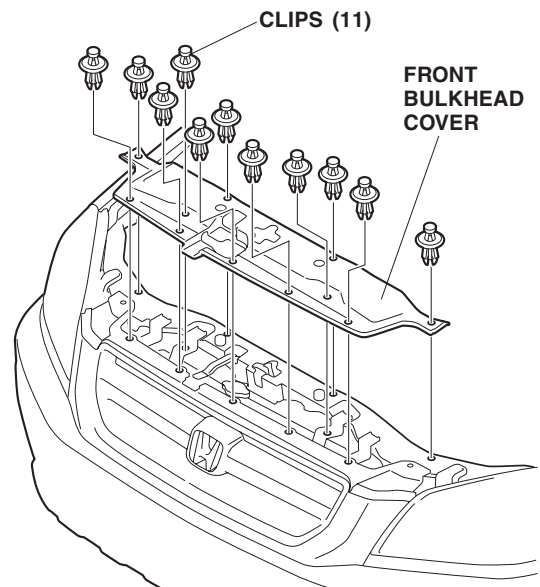

- Remove the two short clips, two self-tapping screws, four bolts, and two long clips that secure the front bumper, then remove the front bumper by pulling it out toward you, and place it on the blanket.

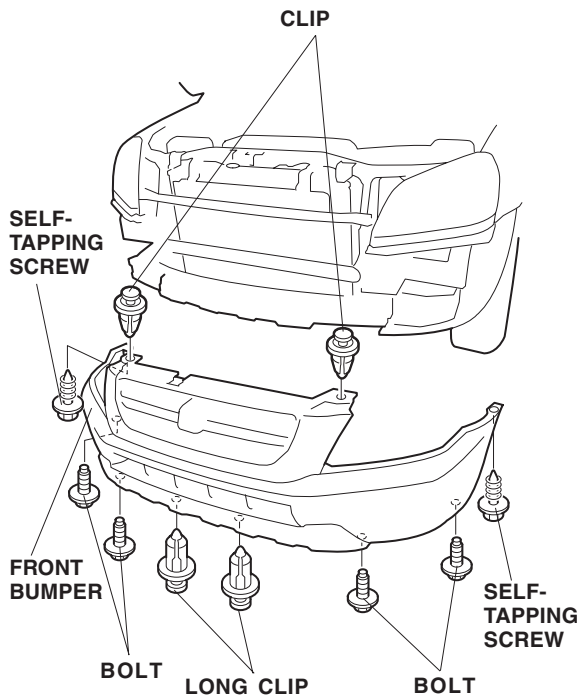

- On the inside of the front bumper, locate the three marks on the left side. Center-punch each of the three marks.

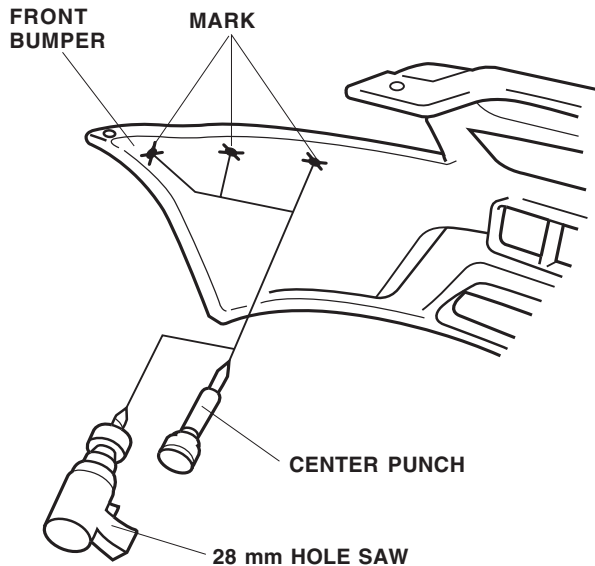

- While wearing eye protection, drill a 28 mm hole through each of the center-punched marks. Remove any burrs from the edges of the holes with a file.

- Place the left front trim piece on the front bumper, and adjust it until it fits snugly. Using strips of masking tape, mark the location of the trim piece.

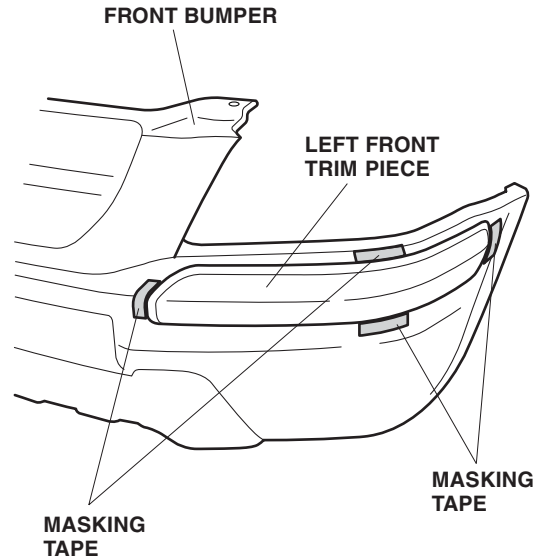

- Attach a strip of masking tape to the ends of the three adhesive backings shown; remove 2 to 3 inches from the ends. Fold the ends up, and tape them to the front of the trim piece. Remove the remaining three adhesive backings.

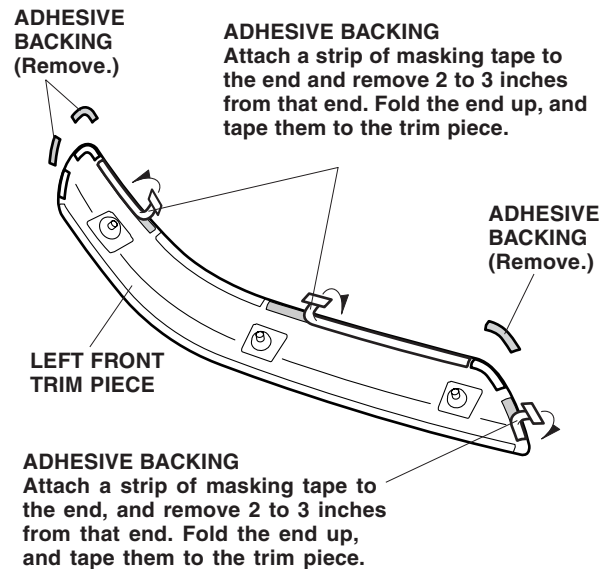

7. Using isopropyl alcohol on a shop towel, clean the area where the trim piece will attach.
8. Position the left front trim piece on the front bumper, and align the edges with the masking tape. Install one bracket and one flange nut flat side up, over each stud of the trim piece. Note the direction of the brackets.

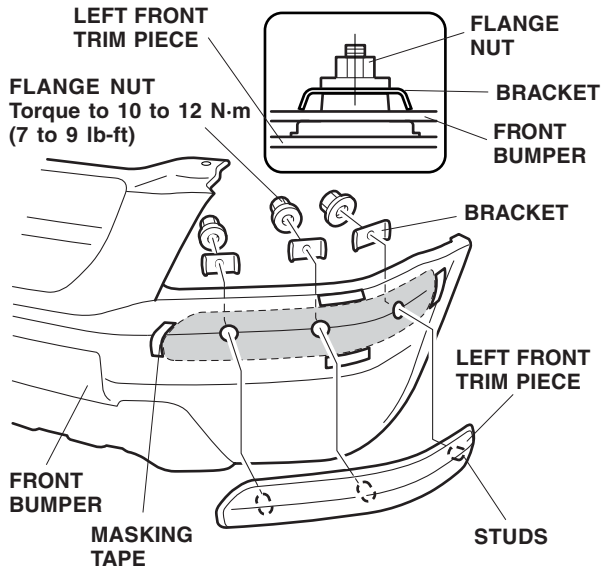

9. Torque the flange nuts to 10 to 12 N·m (7 to 9 lb-ft).
10. While holding light pressure on the left front trim piece, slowly and carefully remove the adhesive backing.

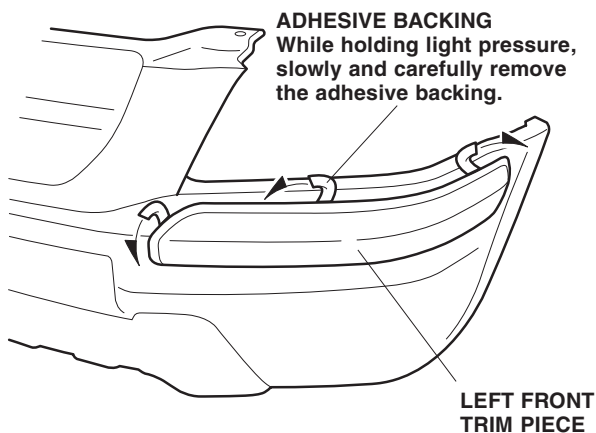

11. Repeat steps 3 through 10 to install the trim piece on the right side of the bumper.
12. Reinstall the front bumper, and the front bulkhead cover.

## Installing the Rear Bumper Trim Piece

13. To release the rear bumper, remove:
  - 2 short self-tapping washer-screws
  - 4 self-tapping screws
  - 2 long self-tapping washer-screws
  - 2 washer-screws
  - 4 clips
  - 5 bolts

Slide the rear bumper out to release the two fender clips. Set the bumper on a blanket.

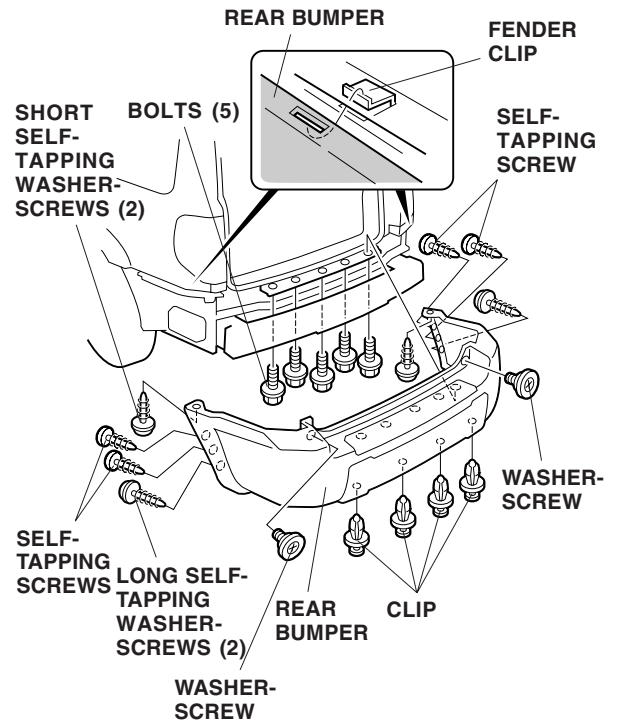

14. On the inside of the rear bumper, locate the three marks on the left side. Center-punch each of the three marks.

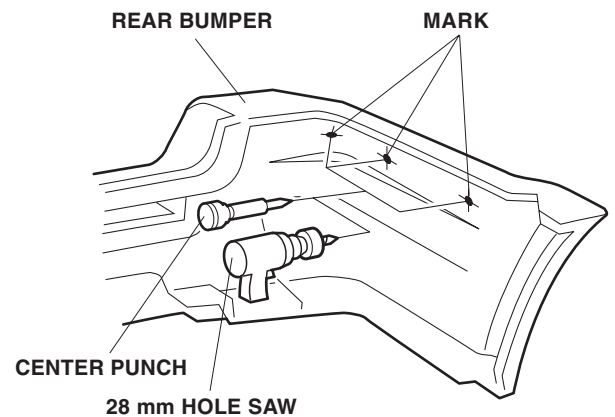

15. While wearing eye protection, drill a 28 mm hole through each of the center-punched marks. Remove all burrs from the edges of the holes with a file.

- Position the left rear trim piece on the rear bumper, and adjust it until it fits snugly. Using strips of masking tape, mark the location of the trim piece.

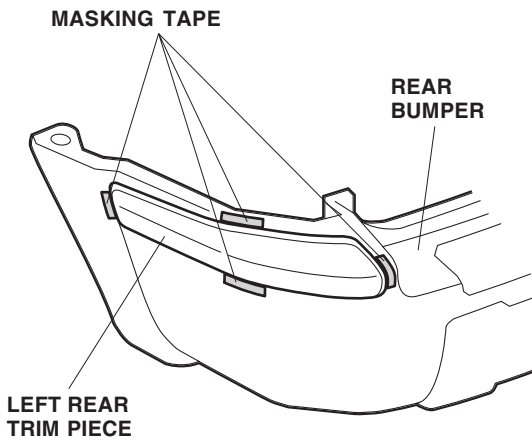

- Attach a strip of masking tape to the ends of the adhesive backings as shown; remove 5 to 6 inches from the ends. Fold the ends up, and tape them to the front of the trim piece. Remove the remaining adhesive backing.

**ADHESIVE BACKING**  
Attach a strip of masking tape to the end, and remove 5 to 6 inches from that end. Fold the ends up and tape them to the front of the trim piece.

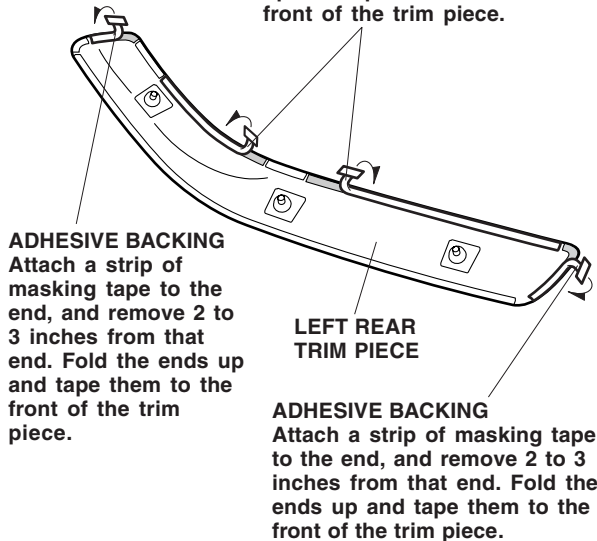

- Using isopropyl alcohol on a shop towel, clean the area where the trim piece will attach.
- Position the left rear trim piece on the rear bumper, and align it with the masking tape. Install one bracket and one flange nut flat side up, over each stud from the trim piece. Note the direction of the brackets.

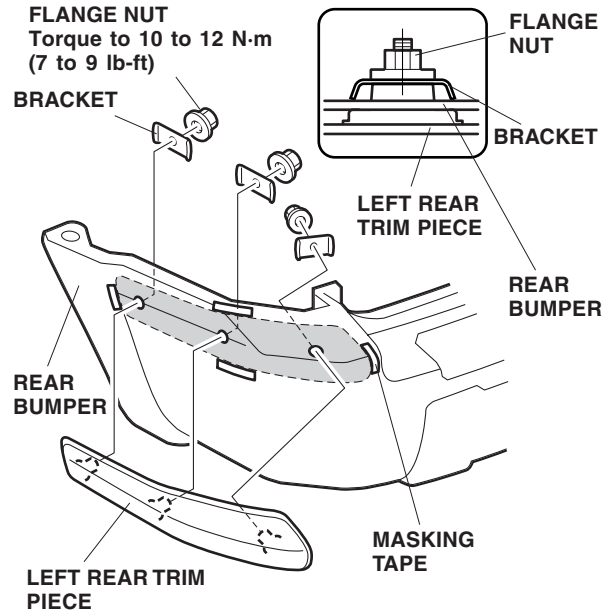

- Torque the flange nuts to 10 to 12 N·m (7 to 9 lb-ft).
- While holding light pressure on the trim piece, slowly and carefully remove the adhesive backings.

**ADHESIVE BACKING**  
While holding light pressure on the trim piece, slowly and carefully remove the adhesive backings.

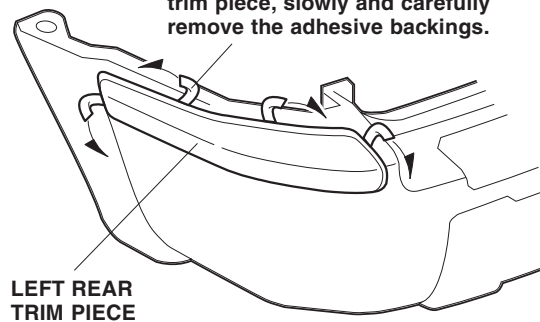

- Repeat steps 14 thru 21 to install the trim piece on the right side of the bumper.
- Reinstall the rear bumper.
- Remove all of the masking tape.