



# INSTALLATION INSTRUCTIONS

Accessory

**XM RADIO SYSTEM**

Application

**2005 ACCORD 2-DOOR  
(LX/EX L4, LX V6)**

Publications No.

**All 27573**

Issue Date

**OCT 2004**

## PARTS LIST

**XM Radio Attachment Kit (sold separately):  
P/N 08B15-SDN-100**

DIN cable



XM radio harness

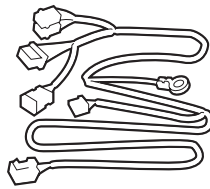

Upper bracket

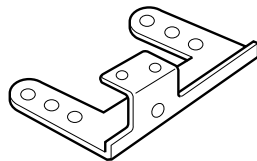

Lower bracket

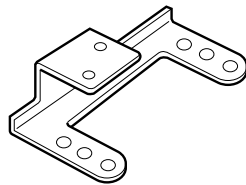

Modulator bracket

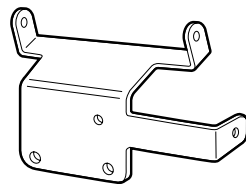

2 Washer-screws, 5 x 10 mm



2 Flange nuts, 5 mm



3 Off-set wire ties with clip

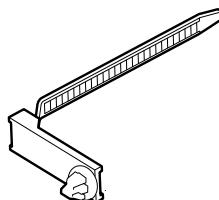

Double-sided adhesive tape

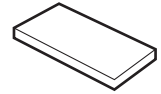

Display unit pocket

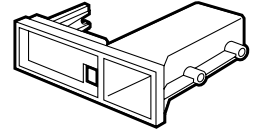

Clip nut



3 Self-tapping screws



Fastener

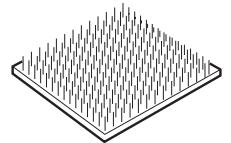

Ground bolt (gold)



6 Washer-screws, 4 x 8 mm



2 Washer-bolts, 6 x 12 mm

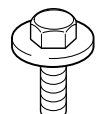

4 Flange nuts, 4 mm



30 Wire ties

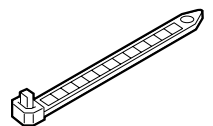

Connector clip



8 Wire tie with clips (two not used)



5 Cushion tapes

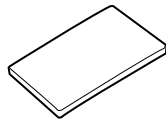

5 EPT sealers

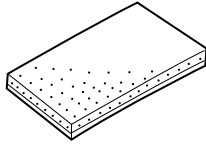

Fuse label

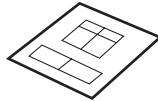

Mini fuse, 5A

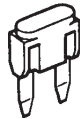

**Antenna Kit (sold separately):  
P/N 08A15-1E1-100**

Antenna cable

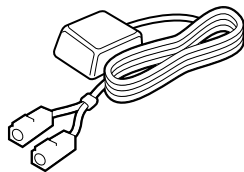

**Base Kit (sold separately):  
P/N 08A15-1E1-000**

Display unit

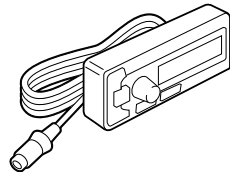

FM modulator unit

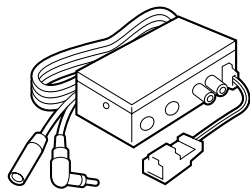

Receiver unit

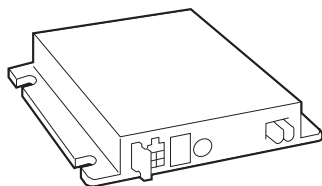

Owner's Manual

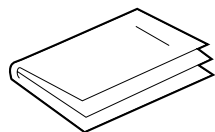

**Audio Attachment Kit (sold separately):  
P/N 08B06-SDA-100**  
(Not required if already equipped with a player.)

Left player bracket



Right player bracket



Left player subbracket

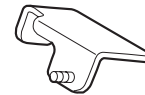

Right player subbracket

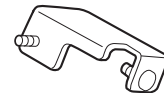

Player base-bracket

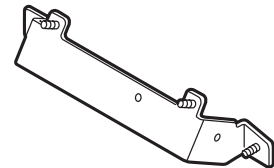

Player panel

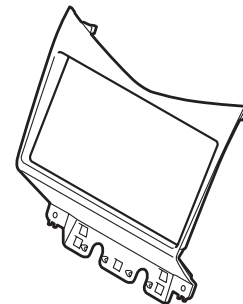

Pocket

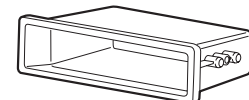

BUS cable  
(Used on vehicles without  
Navigation)

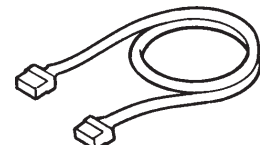

2 Latches



8 Flange nuts, 6 mm



2 Grommet screws



2 Wire ties

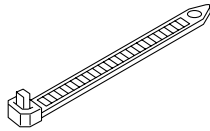

3 EPT sealers

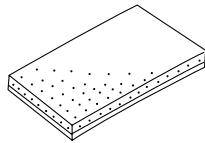

2 Self-tapping screws, 4 x 12 mm



### TOOL AND SUPPLIES REQUIRED

- Phillips screwdriver
- Stubby Phillips screwdriver
- Flat-tip screwdriver
- Isopropyl alcohol
- Shop towel
- Tape measure
- Utility knife
- Hook tool
- Ratchet wrench
- 8 mm and 10 mm Sockets
- Felt-tip pen
- Scissors
- Push pin
- Vinyl tape
- Drill
- 3 mm and 10 mm Drill bits
- Touch-up paint
- Eye protection (face shield, safety goggles, etc.)
- Masking tape

### Illustration of the XM Radio System Installed in the Vehicle

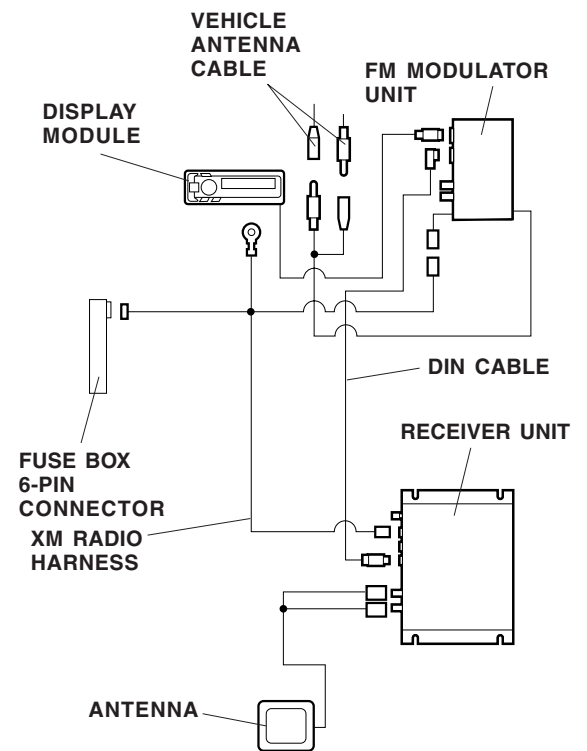
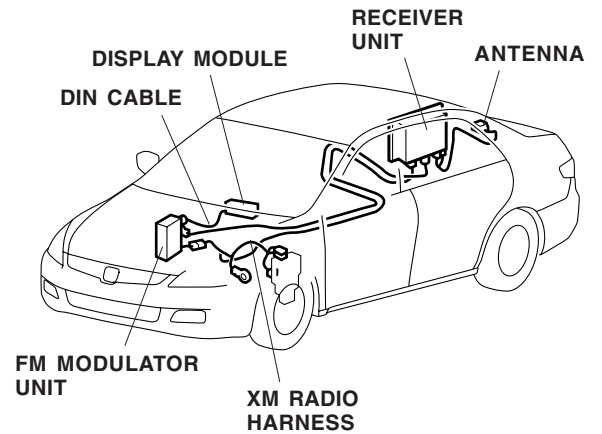

## INSTALLATION

**Customer Information:** The information in this installation instruction is intended for use only by skilled technicians who have the proper tools, equipment, and training to correctly and safely add equipment to your vehicle. These procedures should not be attempted by "do-it-yourselfers."

1. Make sure you have the anti-theft code for the radio, then write down the radio station presets.
2. Disconnect the negative cable from the battery.
3. Remove the trim ring.

### *M/T Vehicle:*

- Squeeze the plastic clip, and pull down on the shift boot. Remove the shift knob by turning it counterclockwise.

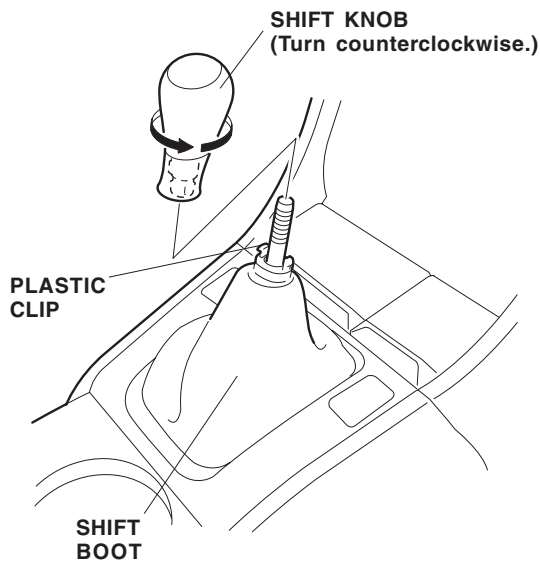

- Gently pry up on the trim ring to release the six clips.
- Unplug the two seat heater connectors (if equipped), and remove the trim ring.

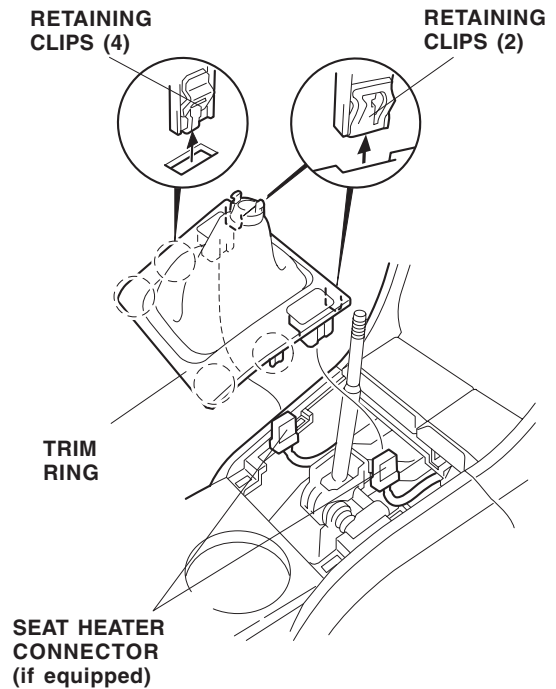

### *A/T Vehicle:*

- Gently pry on the trim ring to release the six clips.
- Unplug the two seat heater connectors (if equipped), and remove the trim ring.

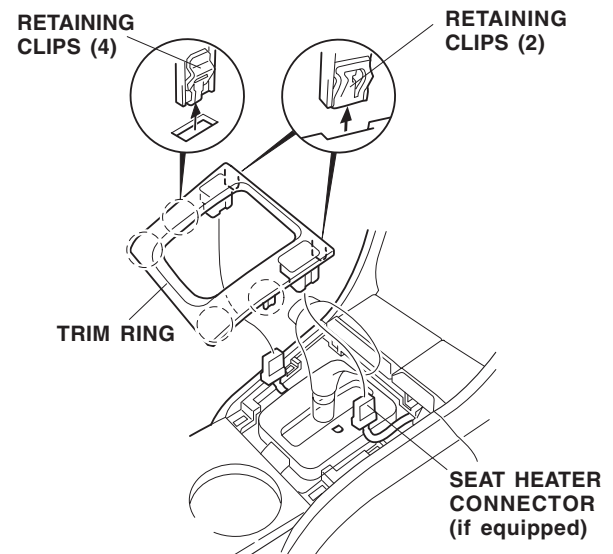

4. Remove the center holder.
  - Open the lid, and remove the coin pocket.
  - Remove the two self-tapping screws.
  - Gently pull out the dashboard center holder to release the two retaining clips, unplug the vehicle connector, and remove the center holder.

**With Coin Pocket:**

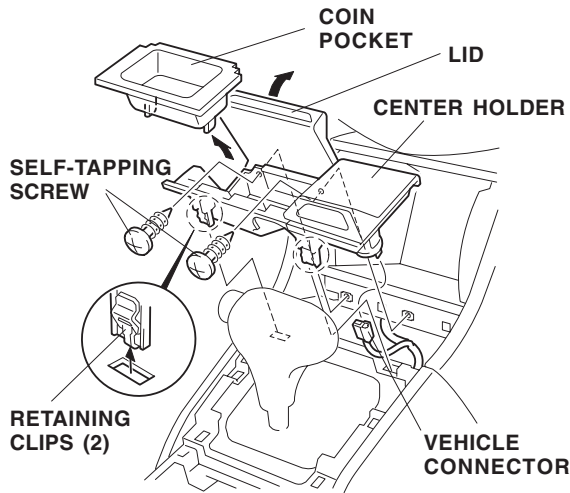

**With Optional Ashtray:**

- Open the lid, and remove the ashtray.
- Remove the two self-tapping screws.
- Gently pull out on the two retaining clips, unplug the cigarette lighter harness connector, vehicle connector, illumination bulb, and remove the center holder.

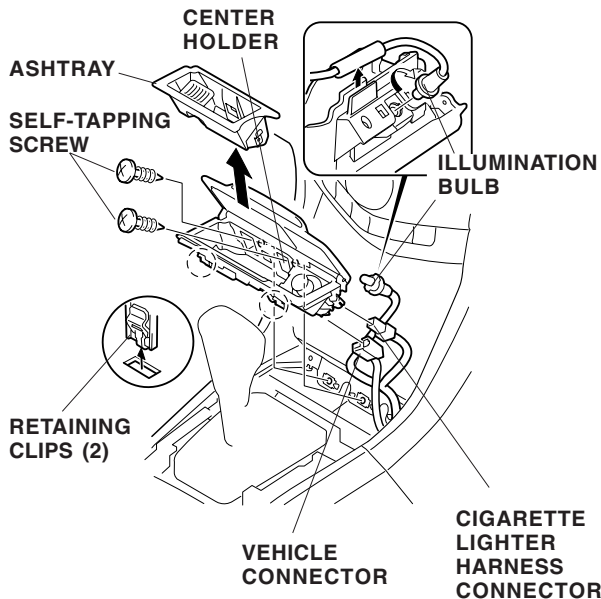

**If the vehicle is equipped with a cassette/MP3/CD player, go to step 13; otherwise, go to step 5.**

5. Remove the pocket:
  - Apply masking tape to the edge of the center panel.
  - Remove the two self-tapping screws.
  - Push in on the bottom of the lid, then pull out on the top by inserting the end of a hook tool between the pocket and center panel. Pull the pocket toward you to release the two retaining clips.
  - Set the pocket aside; it will not be reused.

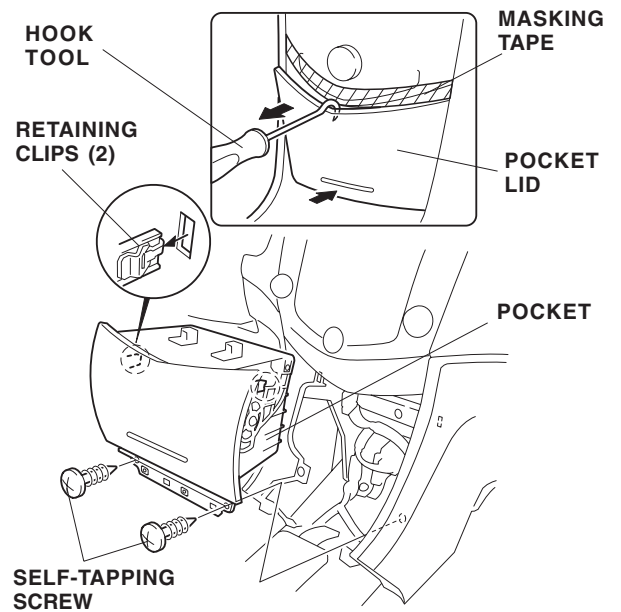

6. Remove the right and left inner covers (one hook and one clip for each cover). Set the inner covers aside; they will not be reused.

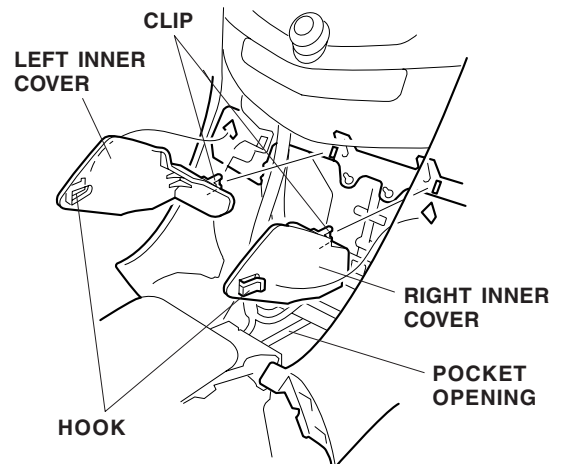

- Remove the vehicle harness clip from the vehicle frame, and move the clip out of the way.

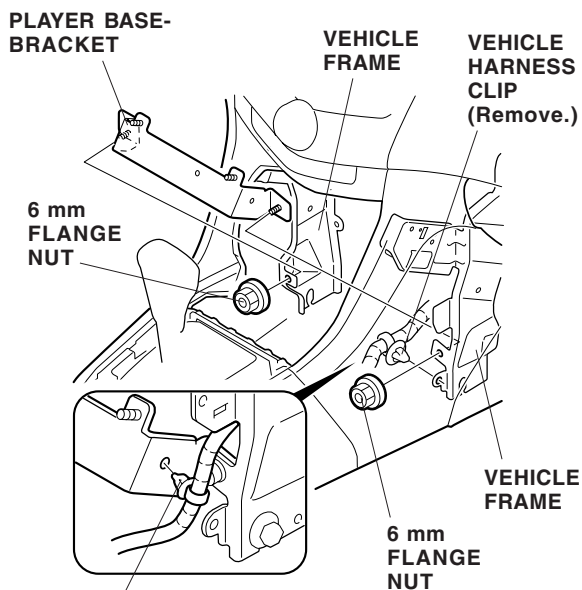

**VEHICLE HARNESS CLIP**  
(Insert into the hole of the player base-bracket.)

- Insert the studs from the player base-bracket into the holes in the vehicle frame from the back. Install the two 6 mm flange nuts while holding the bracket firmly against the vehicle frame. Insert the vehicle harness clip (removed in step 7) into the hole in the player base-bracket.
- Insert the studs of the left and right player subbrackets into the holes in the vehicle frame, and install one 6 mm flange nut on the end of each stud while pushing each subbracket upward.

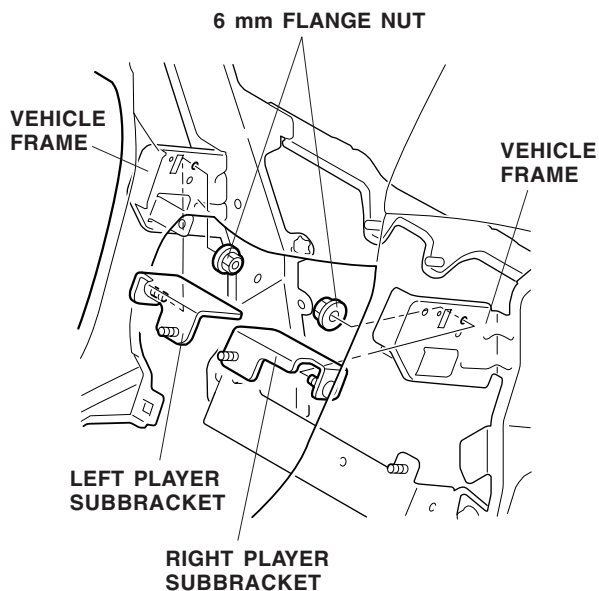

- Get the pocket from the audio attachment kit. Using a utility knife, cut the two lugs off of the pocket.

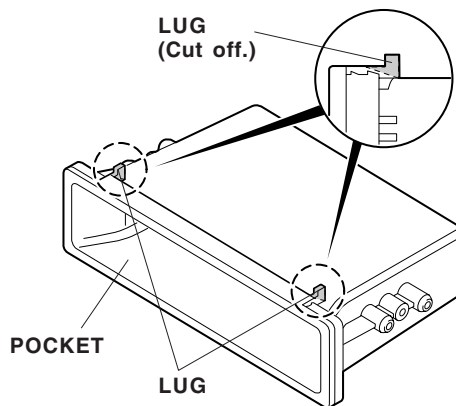

- Install one latch onto the left and right player brackets. Slide the clip nut onto the display module pocket flange.

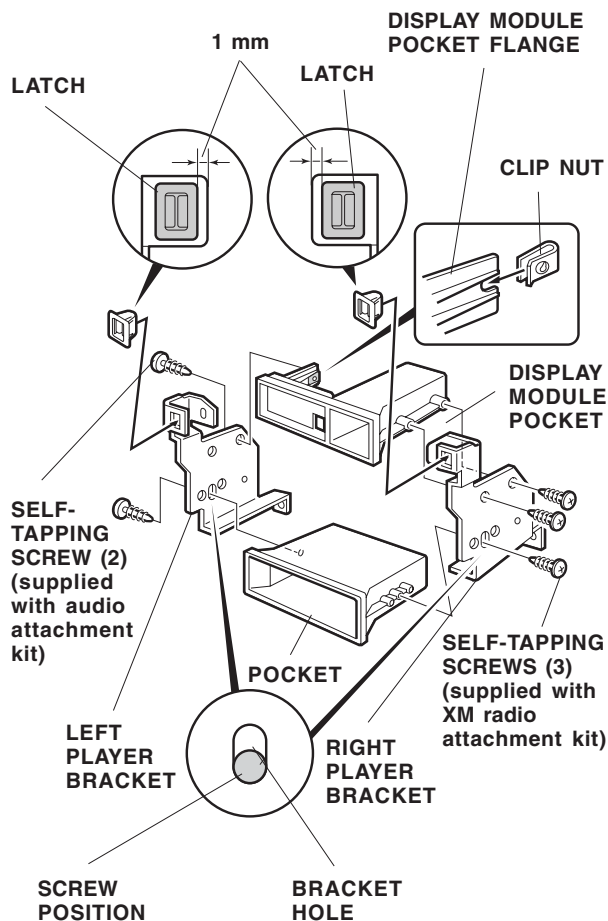

- Set the display module pocket on the pocket with the cut out facing up. Position the left and right player brackets on the display module pocket and pocket, and install five self-tapping screws.

**If the vehicle is not equipped with a cassette/MP3/CD player, go to step 18; otherwise, go to step 13.**

13. Remove the player panel by removing the two self-tapping screws and two clips.

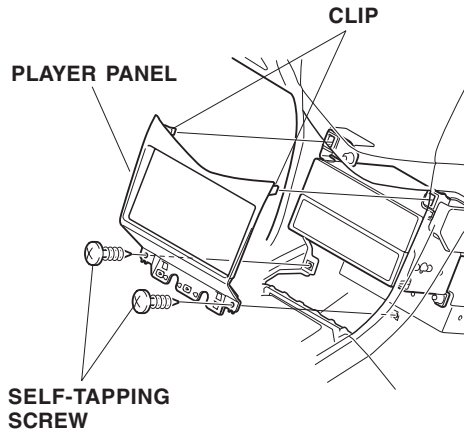

14. Remove the player/pocket assembly. Unscrew the four flange nuts, and pull the assembly out toward you. Unplug the audio subharness cable connector.

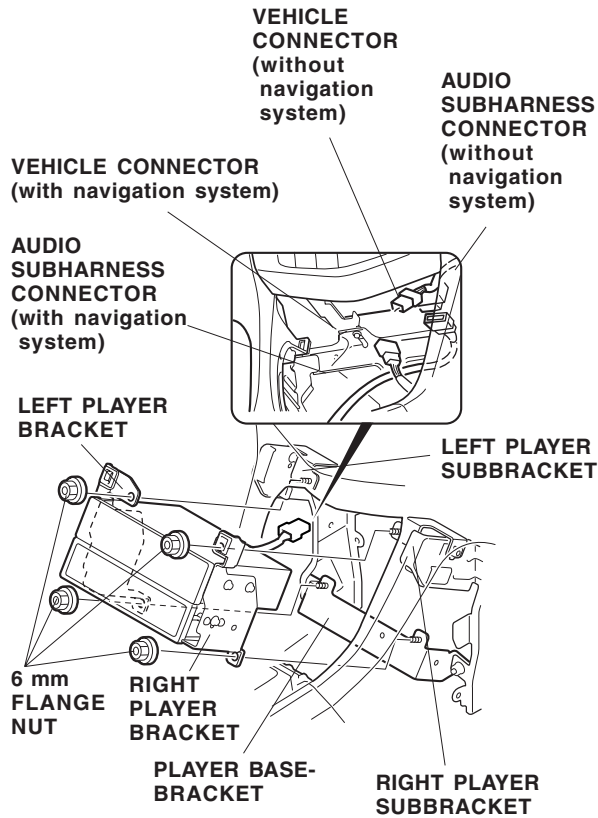

15. Remove the left and right audio brackets (two washer-screws and one self-tapping screw for each bracket). Separate the player and pocket. Set the pocket aside; it will not be reused.

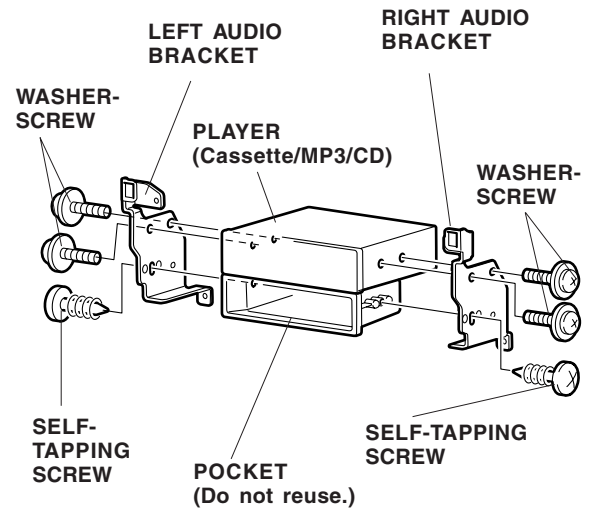

16. Slide the clip nut (supplied) onto the display module flange.

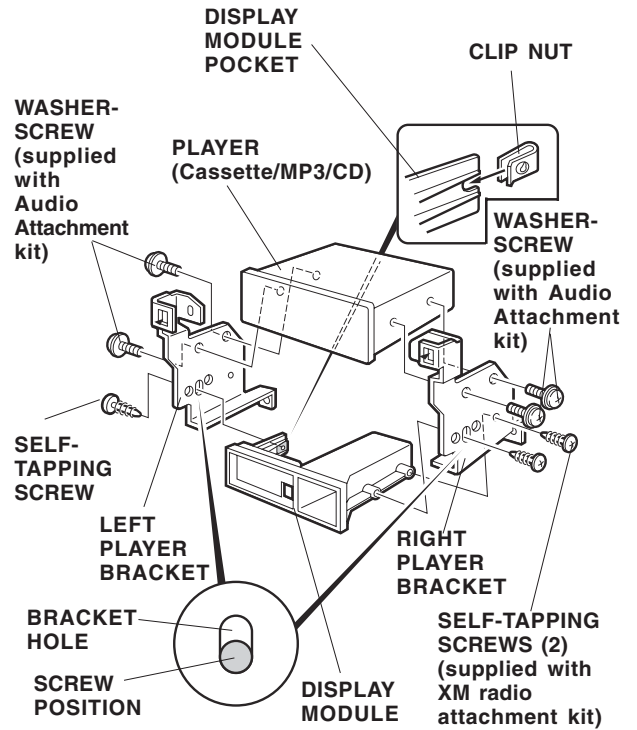

17. Set the player on the display module pocket. Position the left and right player brackets on the display module pocket and player, and reinstall the four washer-screws. Install the three self-tapping screws to secure the display module pocket.

## Installing the Display Unit

18. Attach the display unit to the display unit pocket:

- Using isopropyl alcohol on a shop towel, clean the center on the back of the display unit where the adhesive backing will attach.
- Remove the backing from one side of the double-sided adhesive tape, and attach it to the display unit.
- Remove the remaining backing from the double-sided adhesive tape. Route the display unit cable through the hole of the display unit pocket, and attach the display unit to the display module pocket.

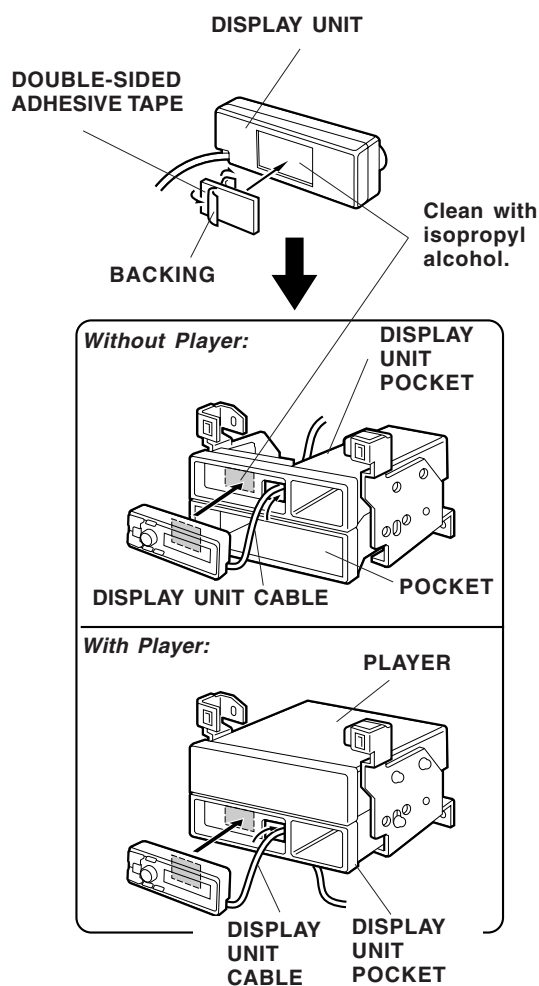

*If the vehicle is not equipped with a cassette/MP3/CD player, go to step 20; otherwise, go to step 19.*

19. Plug the audio subharness cable into the player.

### Cassette Player

Make loops in the audio subharness cable, and secure it with one wire tie, so that the distance between the ends of the cable connector is 200 mm. Plug the audio subharness cable connector into the cassette player connector.

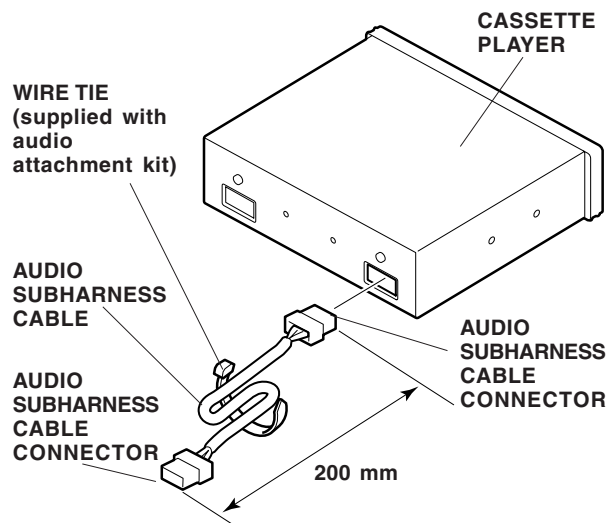

### Multimedia Player

Make loops in the audio subharness cable, and secure it with one wire tie so that the distance between the ends of the cable connectors is 200 mm. Plug the audio subharness cable connector into the multimedia player connector.

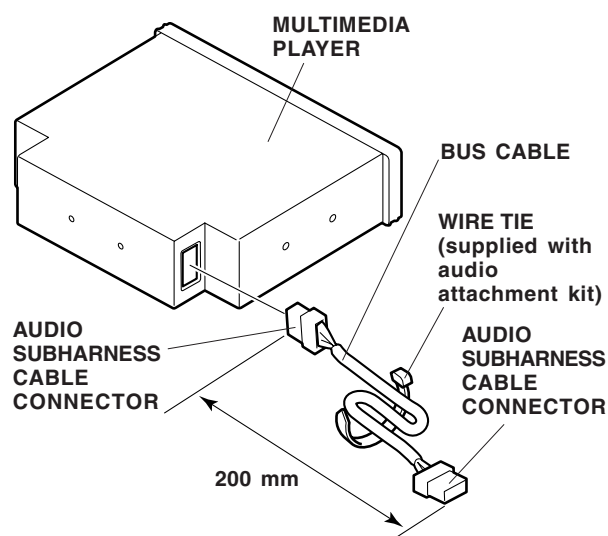



## In-Dash CD Player

- Make loops in the audio subharness cable, and secure it with one wire tie so that the distance between the ends of the cable connectors is 180 mm. Plug the audio subharness cable connector into the connector from the in-dash CD player.
- After connecting, secure the connectors to the rear of the in-dash player with one wire tie from the in-dash CD player kit.

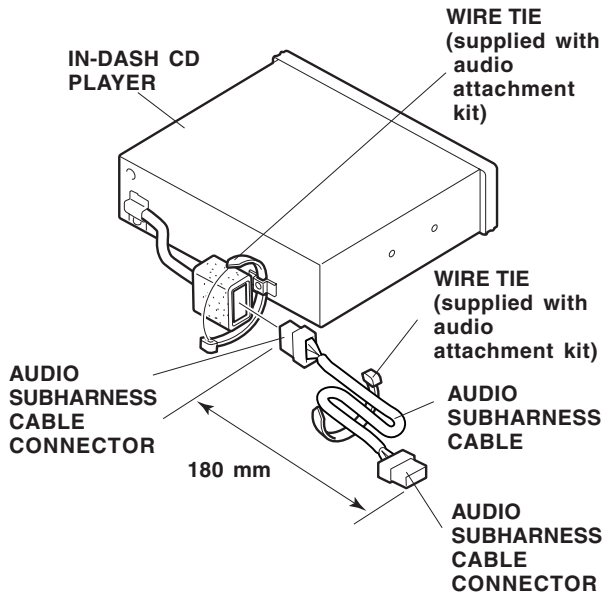

## Routing the XM Radio Harness

20. Remove the beverage holder (pull up to release the six retaining clips).

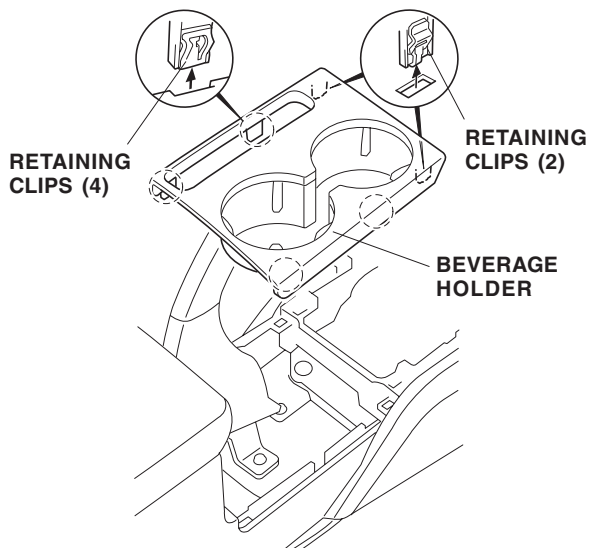

21. Remove the rear console.

- Open the lid, and remove the rear console mat from inside the rear console.
- Remove the two screws and the four self-tapping screws, and unplug the connector and harness clip (if equipped).
- If equipped with a console-mounted CD changer, remove the changer from the rear console.

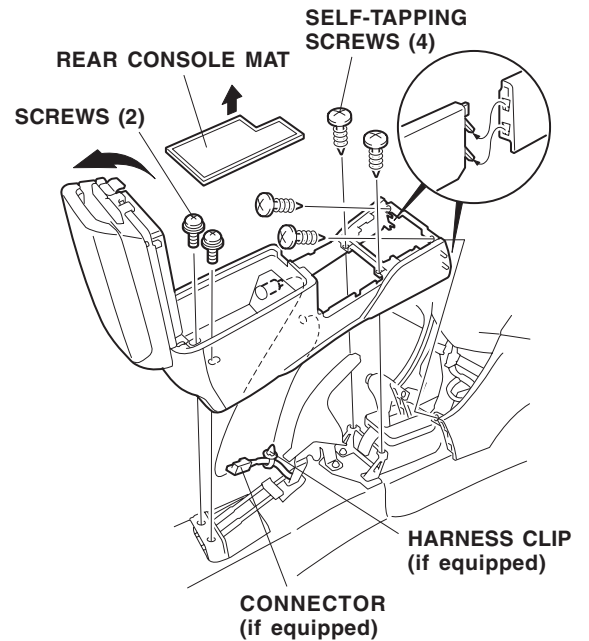

22. Remove the driver's dashboard lower cover:
- Remove the self-tapping screw.
  - Release the four clips on the left side first by pulling out on the driver's dashboard lower cover.
  - After releasing the four clips, insert a flat-tip screwdriver behind the clip at the dashboard frame. Gently twist the screwdriver to release the clip.
  - Release the two clips on the right side. Unplug the vehicle connector, then remove the lower cover.

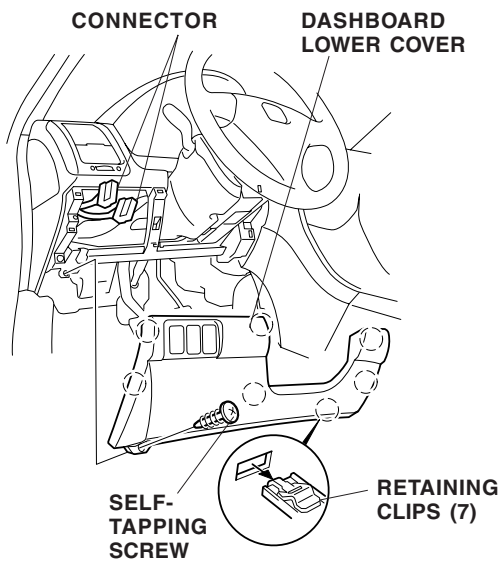

23. If equipped, remove the driver's dashboard under cover (release the three retaining clips, one pin, and one holder).

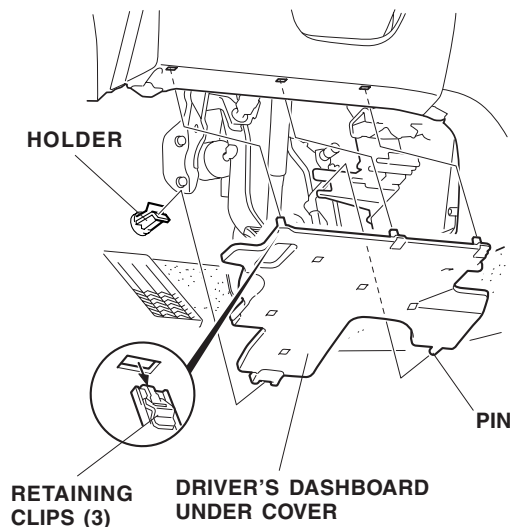

24. Remove the self-tapping screw and the clip that secure the left front console cover. Take care not to damage the clip, and remove the console cover.

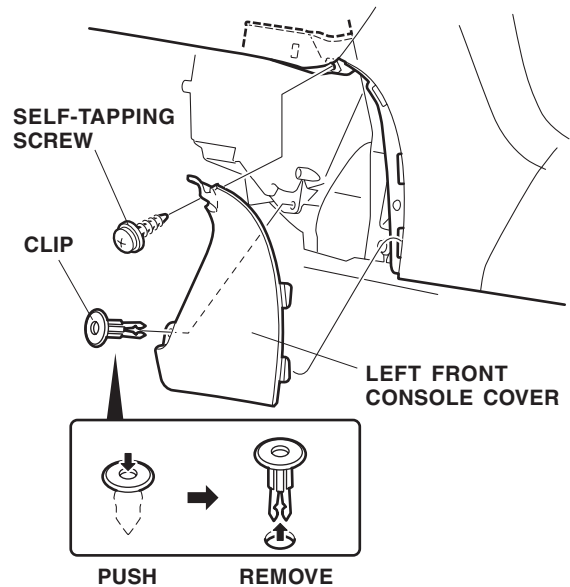

25. On the driver's side of the vehicle, locate the 6-pin connector on the fuse box. Plug the XM radio harness 6-pin connector into the fuse box 6-pin connector.

*NOTE: If the 6-pin connector is already being used by another accessory, locate the 6-pin connector taped to the XM radio harness. Remove the dummy connector from the harness, and plug the other accessory's harness 6-pin connector into the XM radio harness.*

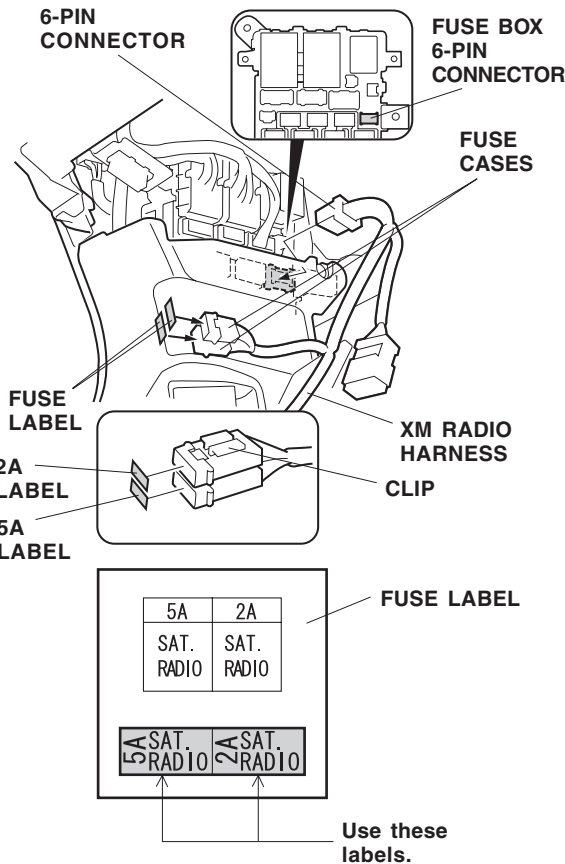
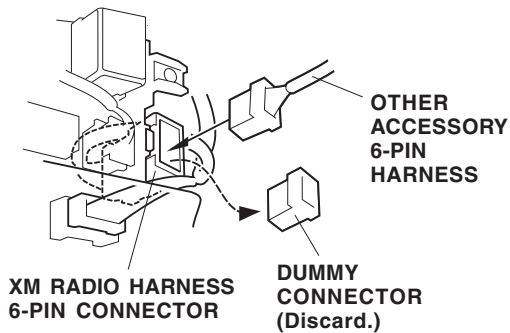

26. Attach the fuse labels to the fuse cases on the XM radio harness.

27. Install the XM radio harness fuse cases and the 6-pin dummy connector to the fuse box case.

**Fuse case position**

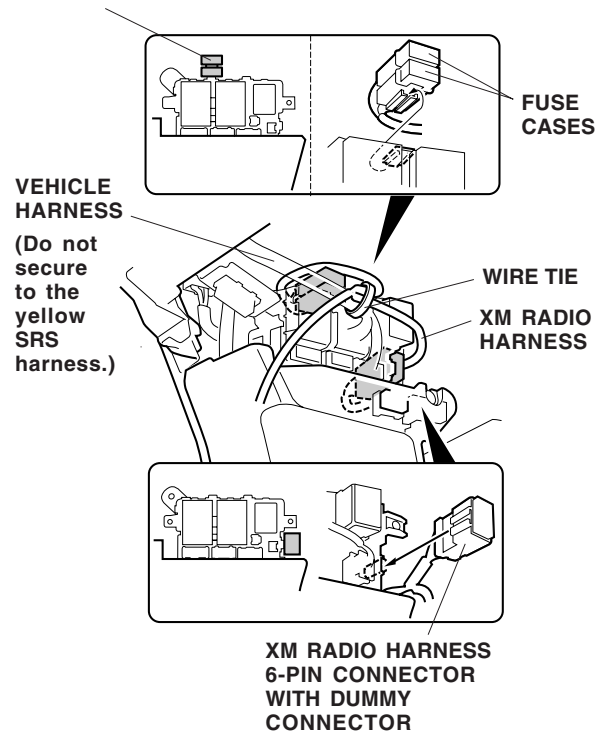

28. Secure the XM radio harness to the vehicle harness with one wire tie. Do not secure it to the yellow SRS harness.
29. Route the XM radio harness under the steering shaft and toward the center console.

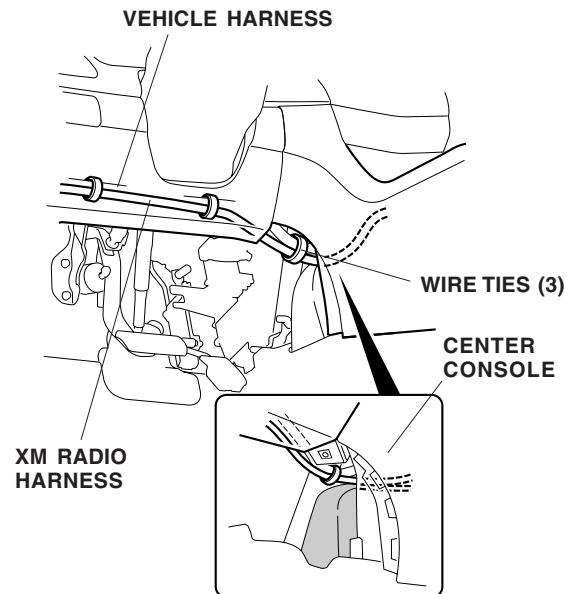

29. Loosely attach the XM radio harness to the vehicle harness with three wire ties.

30. Inside the center console, locate the welded nut on the vehicle stay. Attach the XM radio harness ground terminal to the welded nut with the ground bolt supplied.

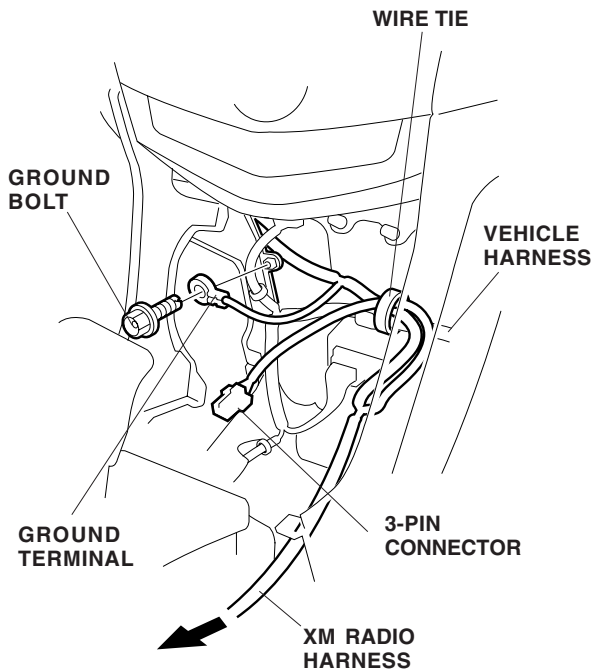

31. Secure the XM radio harness to the vehicle harness with one wire tie. Route the 3-pin connector, and the remaining end of the XM radio harness toward the rear of the vehicle; they will be routed later.

### FM Modulator Unit Installation

32. To protect the center panel, attach masking tape to the center panel in the area shown.

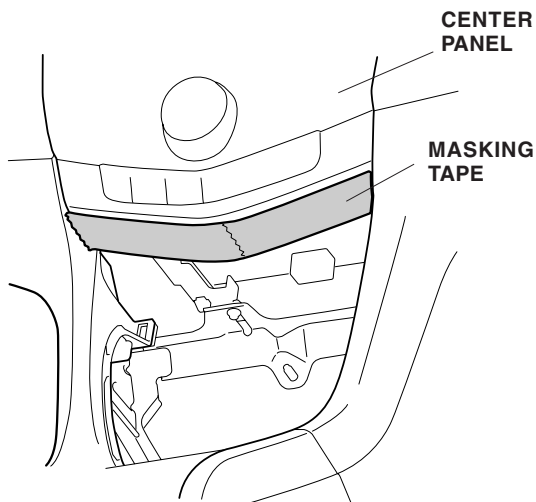

33. Attach the modulator bracket to the player base-bracket with two 5 x 10 mm washers and two 5 mm flange nuts.

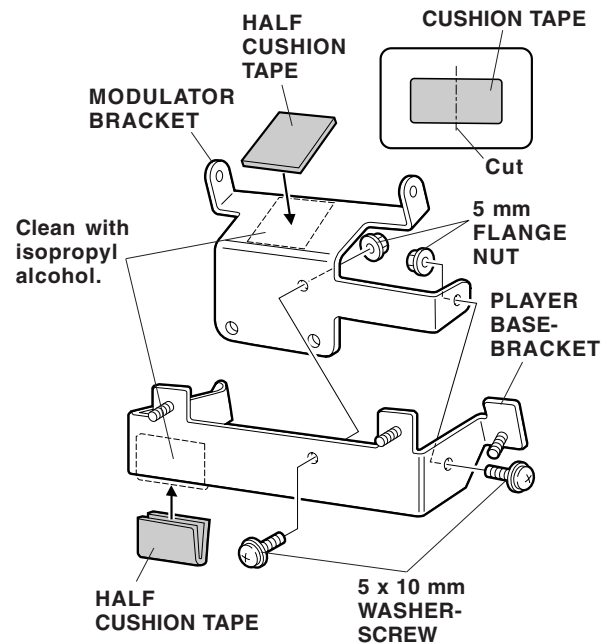

34. Using scissors, cut one cushion tape in half. Using isopropyl alcohol, clean the bonding surfaces of the brackets, and attach the half cushion tapes to the brackets in the area shown.
35. Install the FM modulator unit to the modulator bracket with two 4 x 8 mm washer-screws. Attach the connector clip from the FM modular unit harness into the hole in the player base-bracket.

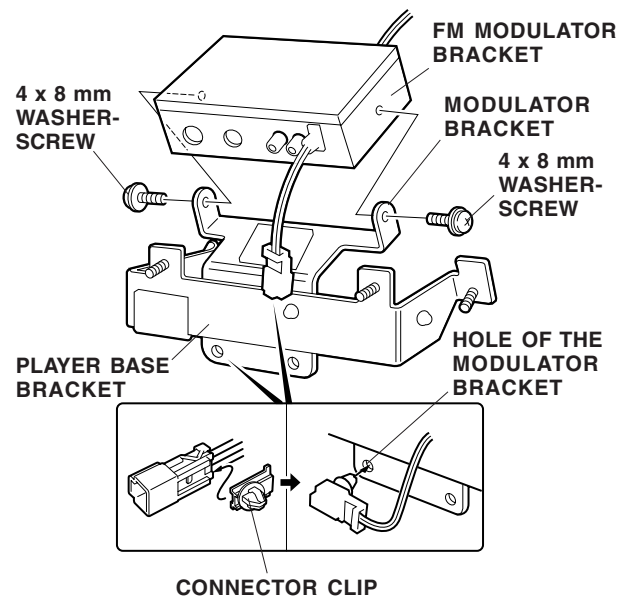

- Insert the studs from the player base-bracket into the holes in the vehicle frame from the back, then install the two 6 mm flange nuts while holding the bracket firmly against the vehicle frame.

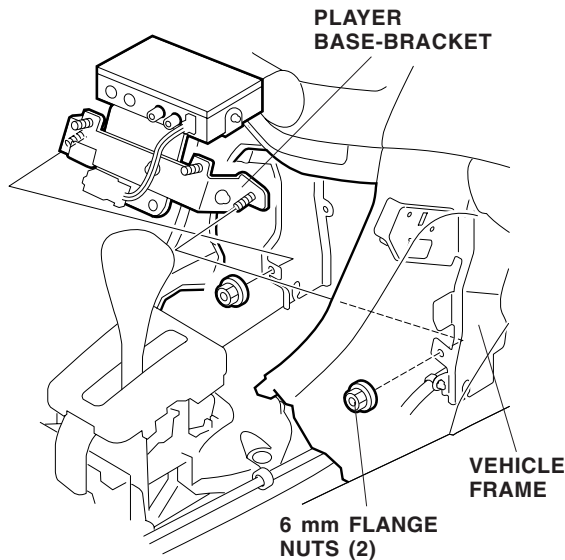

- Connect the XM radio harness 3-pin connector to the FM modulator unit harness 3-pin connector.
- Get a DIN cable from the XM radio attachment. Plug the 90° end of the DIN cable connector into the FM modulator unit, then route the DIN cable rearward along the XM radio harness.

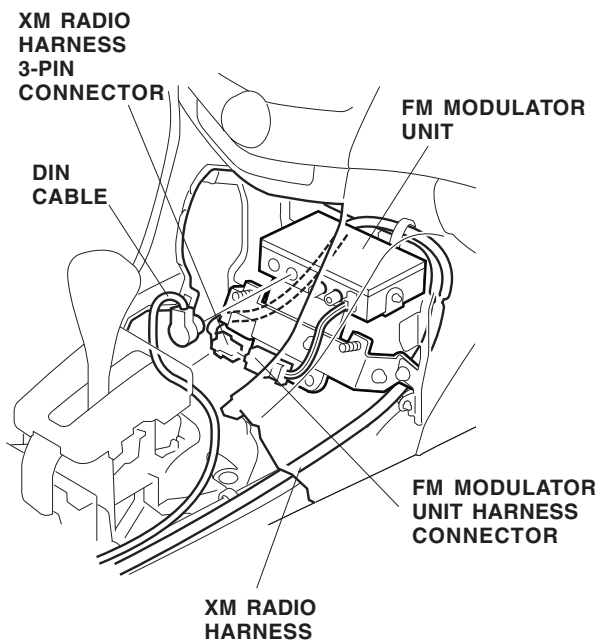

- Unplug the vehicle antenna cable, and plug it into the FM modulator unit antenna cable. Plug the other end of the FM module antenna jack into the vehicle antenna cable.

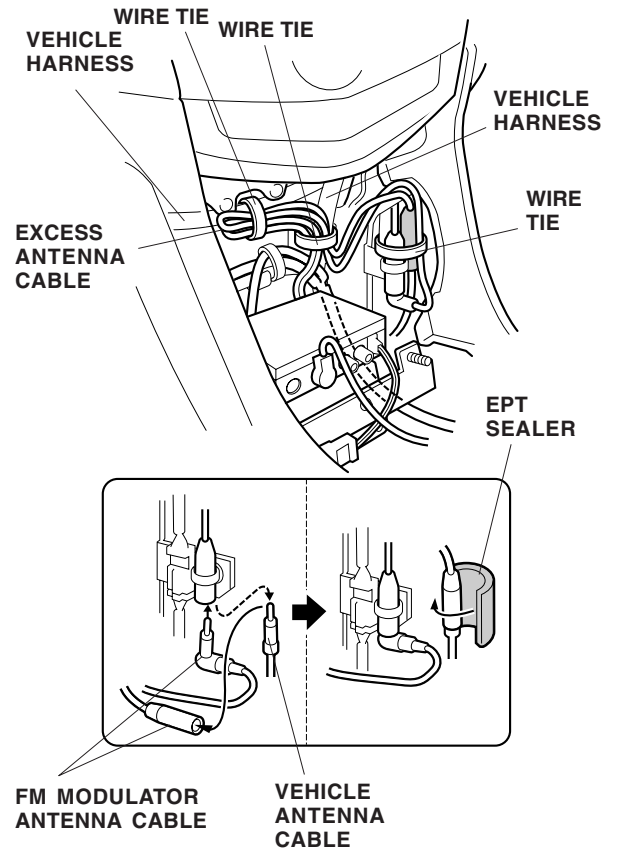

- Wrap one EPT sealer around the antenna jack, and secure the antenna cable to the vehicle antenna cable with the one wire tie. Secure both antenna cables to the vehicle harness with one wire tie.
- Loop the excess antenna cable from the FM modulator, and secure the excess cable to the vehicle harness with two wire ties.

42. Plug the display module cable into the FM modulator unit. Pull the excess length of the cable out from under the display module unit.

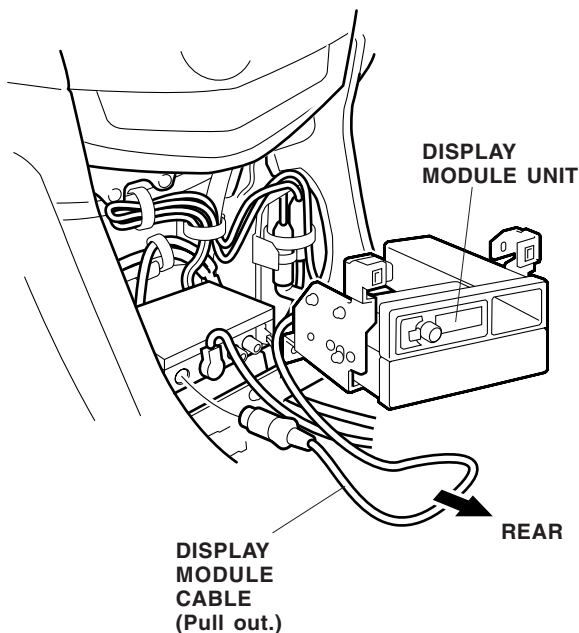

43. If equipped with a player, plug the BUS cable connector into the vehicle connector.

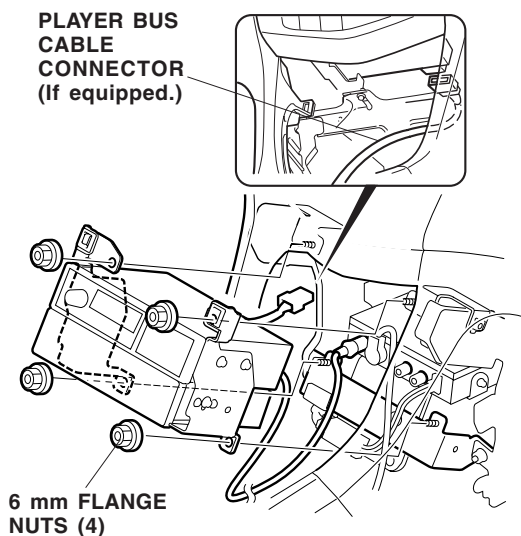

44. Install the display module assembly onto the studs from the left and right player subbrackets, and install the 6 mm flange nuts. Tighten the flange nuts securely.

45. Loop the excess display module cable along the DIN cable and the vehicle harness, then secure the display module cable, and the DIN cable with one wire tie with clip. Insert the clip from the wire tie into the modulator bracket hole.

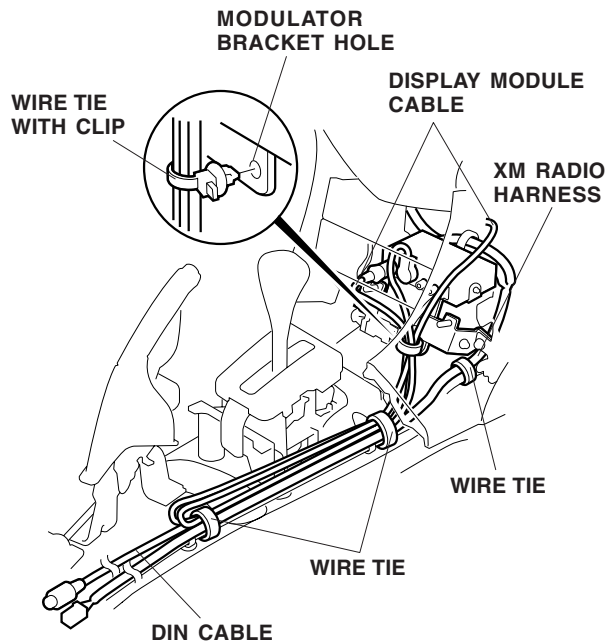

46. Near the subbracket, secure the XM radio harness to the vehicle harness with one wire tie.
47. Secure the excess length of DIN cable and XM radio harness to the vehicle harness with two wire ties.
48. If the vehicle is not equipped with a player, attach the two grommet screws to the player panel in the square holes as shown.

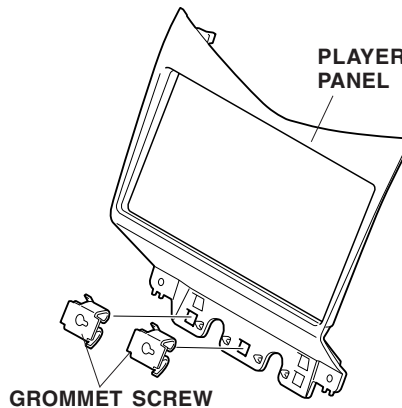

49. Get one EPT sealer. Measure the EPT sealer as shown, and cut it into three pieces.

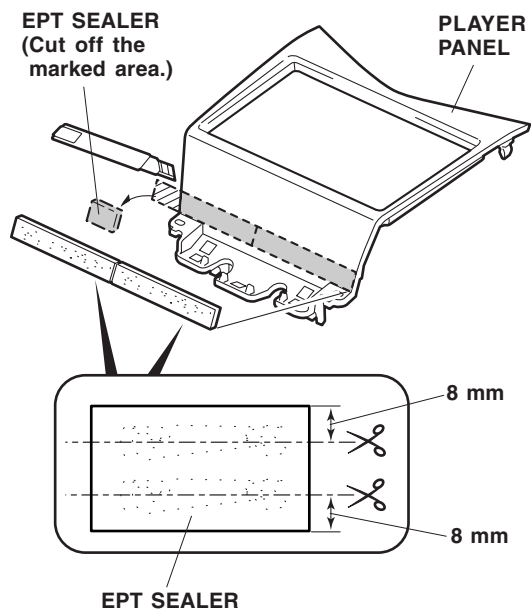

50. Using isopropyl alcohol on a shop towel, clean the player panel in the area shown. Attach the two cut pieces of the EPT sealer to the player panel, and cut off the excess.
51. Attach the player panel by inserting the clips into the latches, and install two self-tapping screws from the kit, or reinstall the two self-tapping screws you removed in step 13. Remove the masking tape.

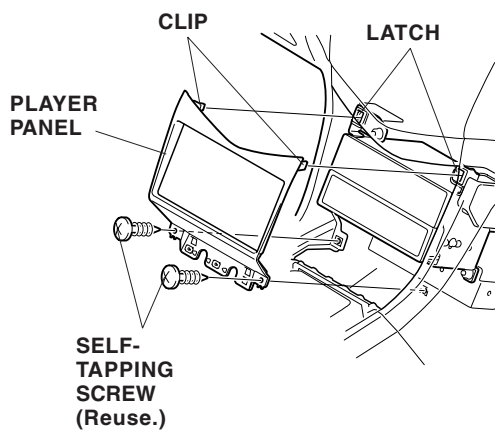

52. Inside the passengers' compartment, remove the rear seat cushion by removing the bolt and releasing the two locks (pull the lock out toward you).

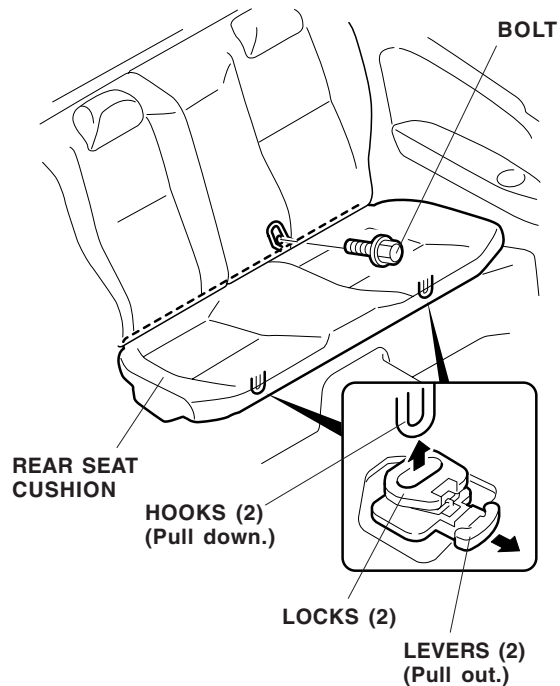

53. Inside the trunk, fold the right and left seatbacks down by pulling the strap and pushing forward on the seat.

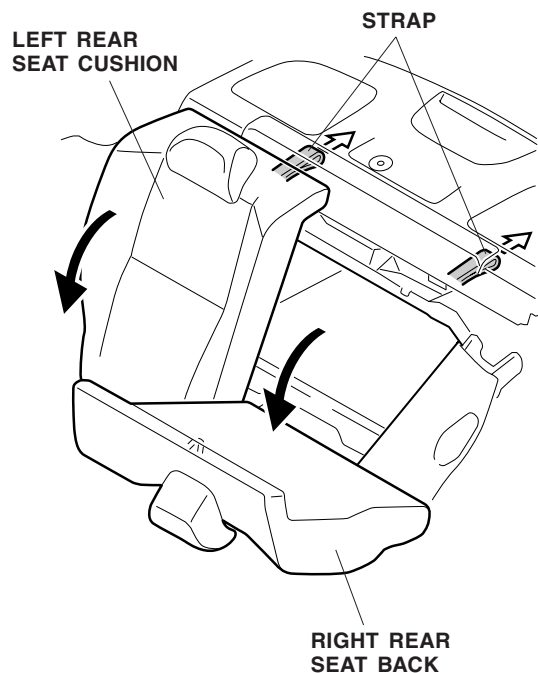

54. Remove the spare tire cover (one clip).

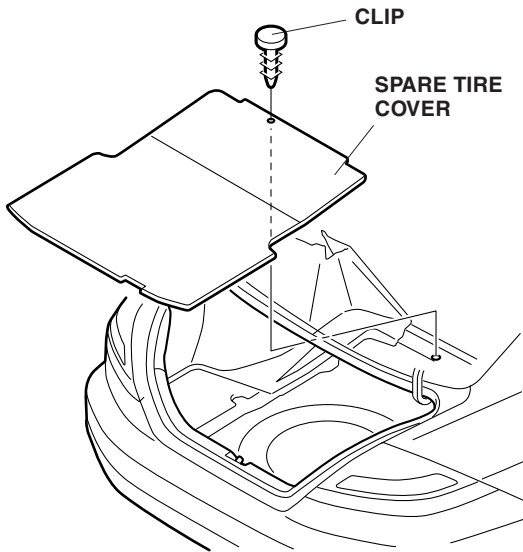

55. Remove the trunk weatherstrip in the area shown, then remove the rear trim panel (four clips).

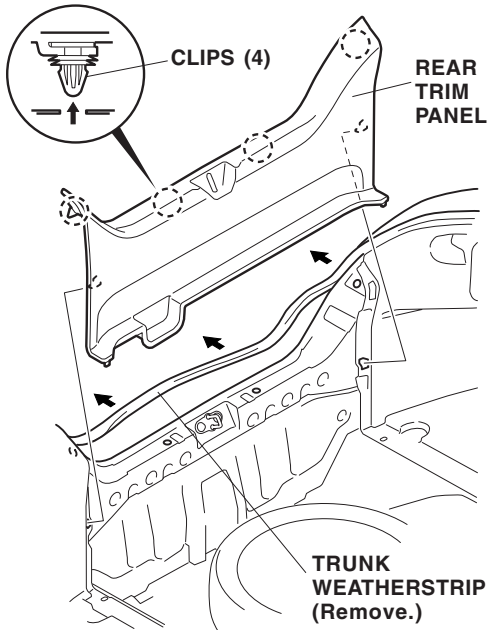

56. Remove the jack cover and the jack.

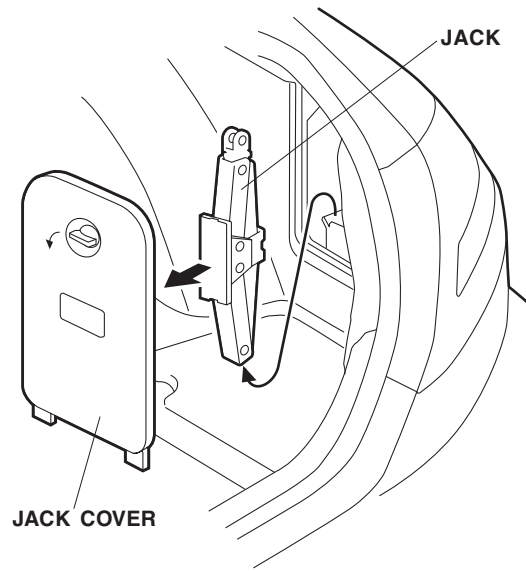

57. Remove the hook from the right side trunk liner (one bolt, hook and washer).

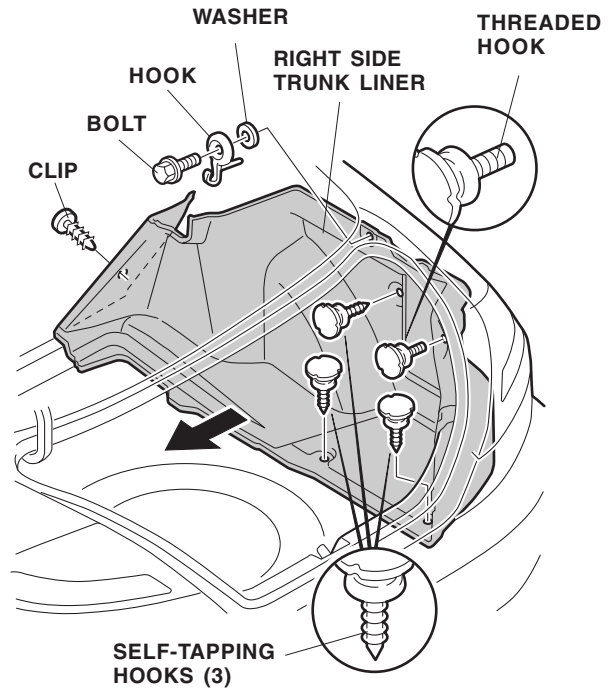

58. Remove the right side trunk liner (three self-tapping hooks, one threaded hook and one clip).



58. Inside the trunk area, unplug the high mount brake light harness connector. Inside the cabin, remove the high mount brake light from the rear shelf by releasing the four hooks, and pulling out the brake light assembly. Take care not to damage the clips.

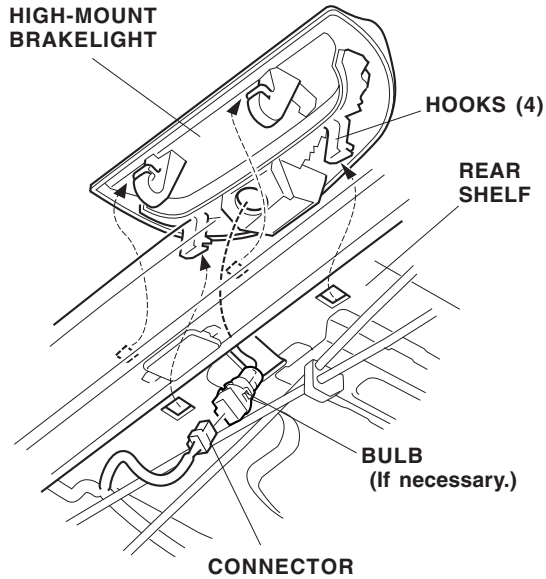

59. Route the XM radio harness and the DIN cable along the vehicle harness toward the parking brake lever, and under the floor carpet. Secure the XM radio harness and the DIN cable to the vehicle harness with two wire ties in the areas shown.

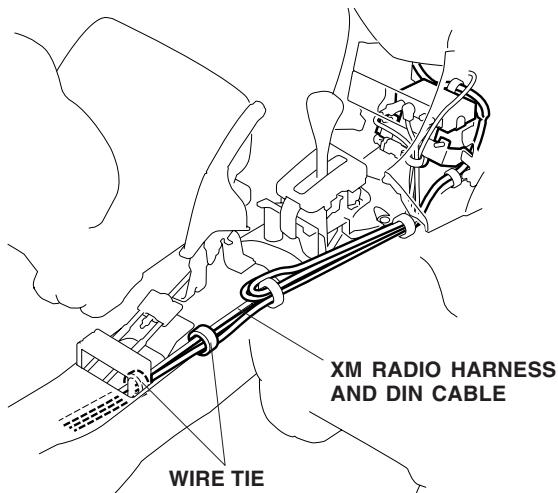

60. Raise the rear seat back. Pull the XM radio harness and DIN cable out from under the floor carpet and toward the passengers' side of the vehicle. Secure the XM radio harness and the DIN cable to the vehicle harness with two wire ties.

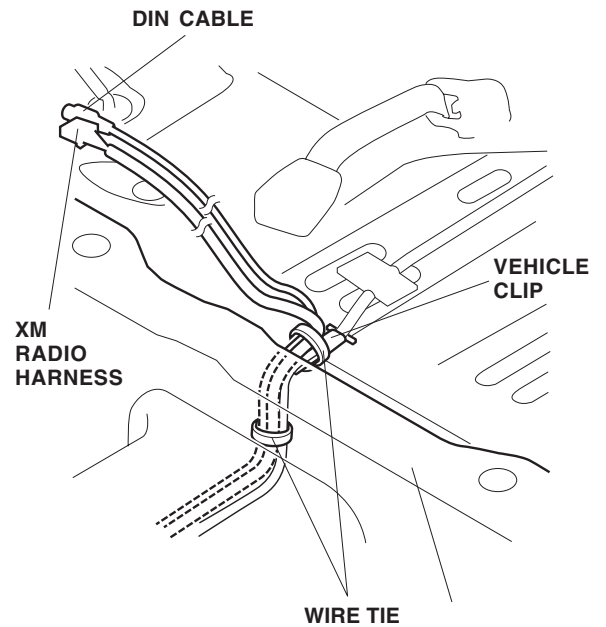

61. Continue routing the XM radio harness and DIN cable along the vehicle harness toward the trunk. Using isopropyl alcohol, clean the areas where the cushion tapes will attach, then secure the XM radio harness and DIN cable to the vehicle panel with five cushion tapes.

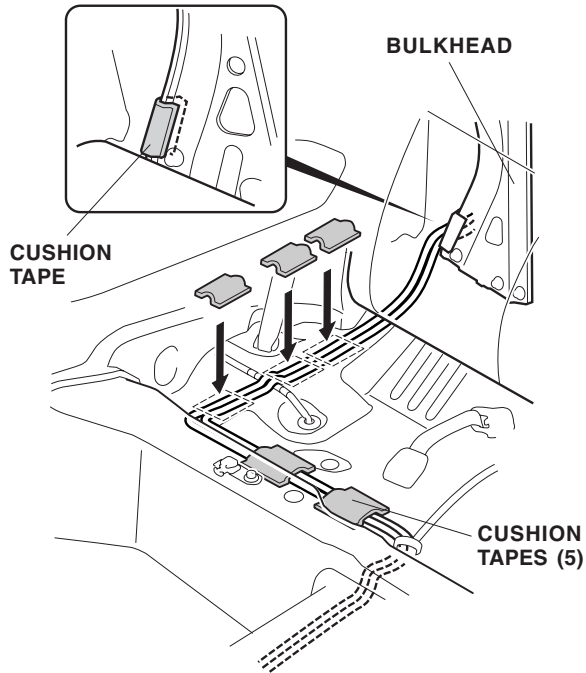

62. Using isopropyl alcohol, clean the bulkhead area where the cushion tape will attach. To prevent damage to the XM radio harness and DIN cable, attach the cushion tape to the bulkhead edge in the area shown.

63. Inside the trunk, install the two wire ties with clip to the DIN cable, and XM radio harness, and push the clips into the holes in the bulkhead.

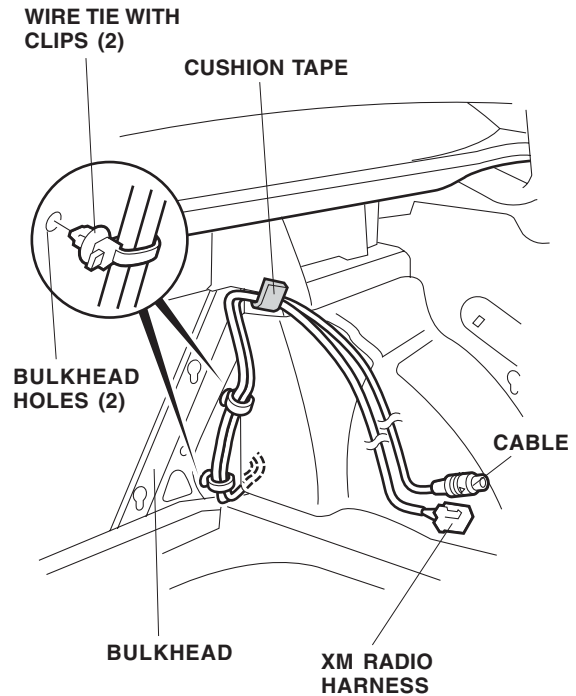

64. Using isopropyl alcohol on a shop towel, clean the area where the cushion tape will attach. Attach the DIN cable and XM radio harness to the vehicle frame with one cushion tape.

### Installing the Antenna

65. Get the antenna kit. Route the antenna cable into the trunk area through the high-mount brakelight opening. Clean the edge of the rear shelf, and attach one cushion tape to the edge of the rear shelf.

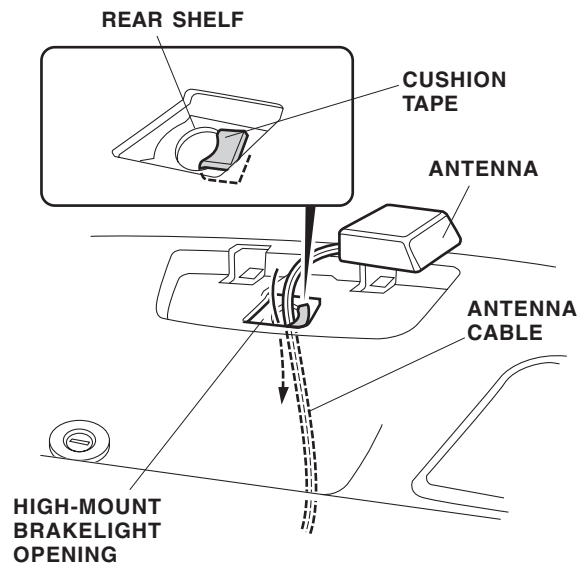

66. Temporarily fit the high-mount brake light onto the rear shelf.

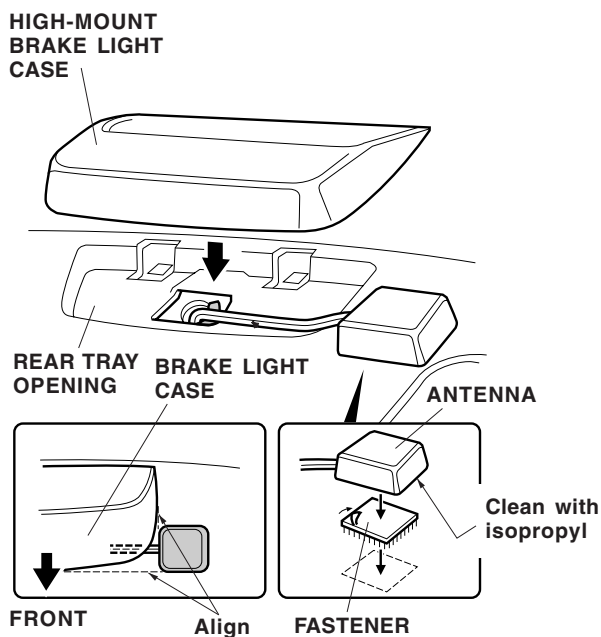

67. Using isopropyl alcohol on a shop towel, clean the bottom of the antenna. Remove the adhesive backing from the fastener, then attach the fastener to the bottom of the antenna. Attach the antenna onto the rear rear shelf.
68. Measure and mark the high-mount brake light case. Using a utility knife, cut a groove in the brake light case. Remove any burrs from the edges of the groove.

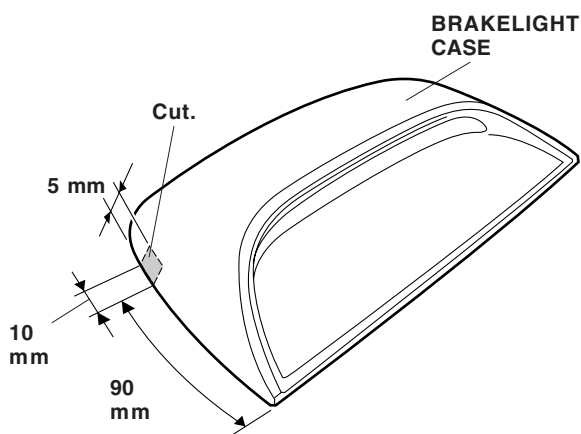

69. Route the antenna cable through the groove in the high mount brake light case, and reinstall the high mount brake light case.

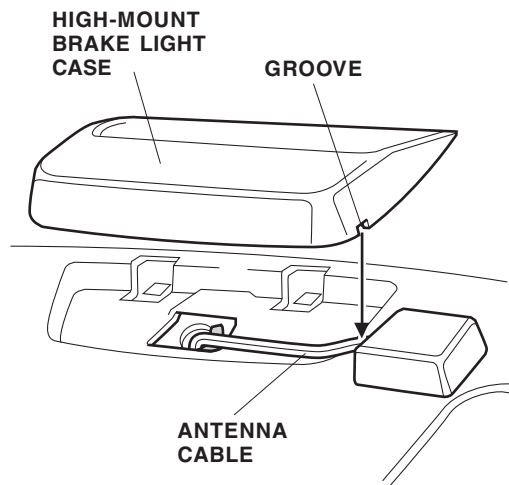

70. Route the antenna cable along the vehicle harness, and secure it to the vehicle harness with seven wire ties in the areas shown.

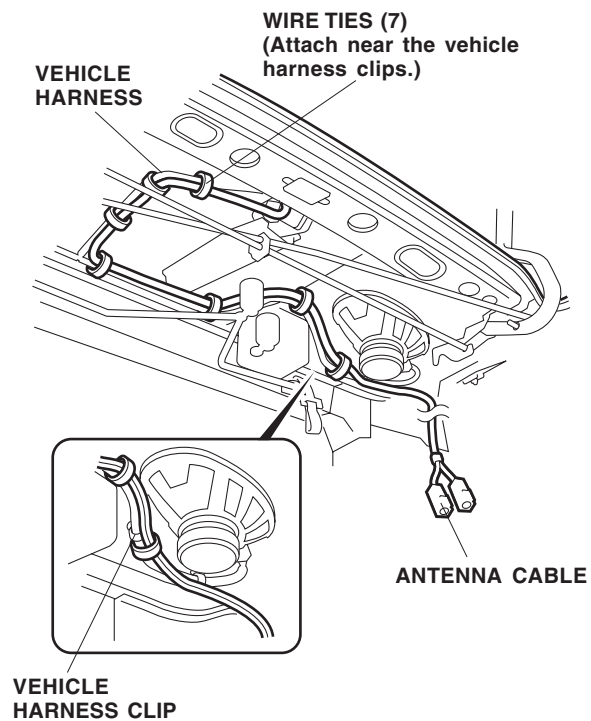

71. Attach one wire tie with clip to the antenna cable, the XM radio harness and the DIN cable in the area shown. Push the clip from the wire tie with clip into the body hole.

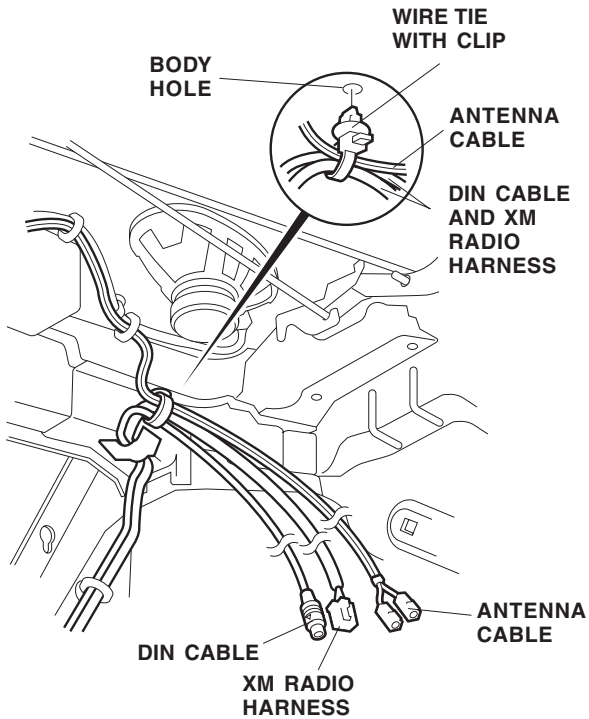

72. Route the antenna cable, the XM radio harness, and the DIN cable along the trunk side panel. Loosely attach the three off-set wire ties with clip around the antenna cable, the XM radio harness, and the DIN cable, then push the clip from each wire tie into the three holes in the trunk side panel.

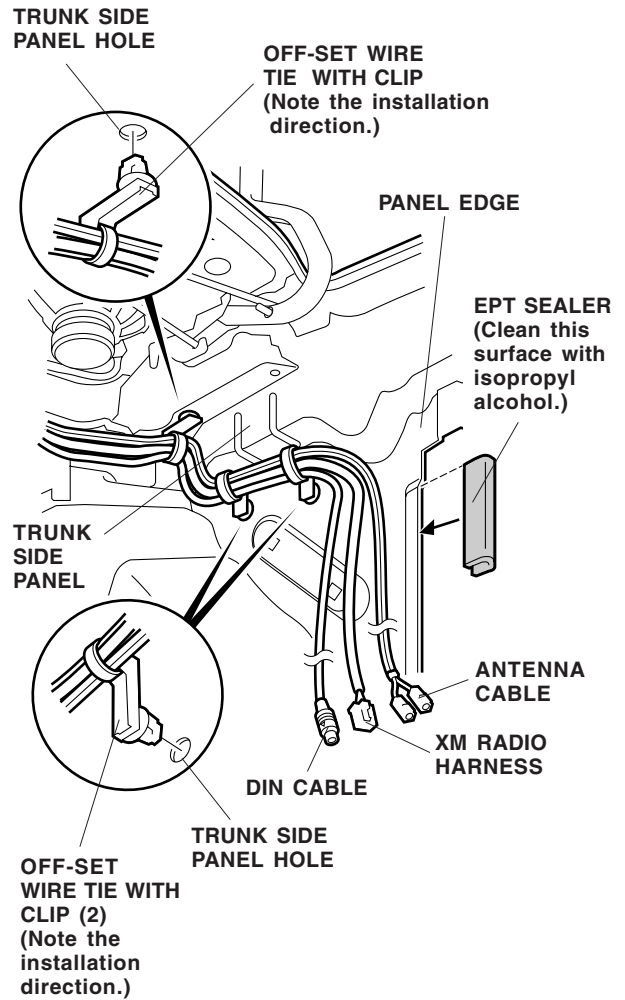

73. Using isopropyl alcohol on a shop towel, clean the bonding surface on the panel edge, attach one EPT sealer to the panel edge in the area shown.

74. Install the upper and lower unit brackets to the receiver unit using two 4 x 8 mm washer-screws, and two 4 mm flange nuts for each bracket.

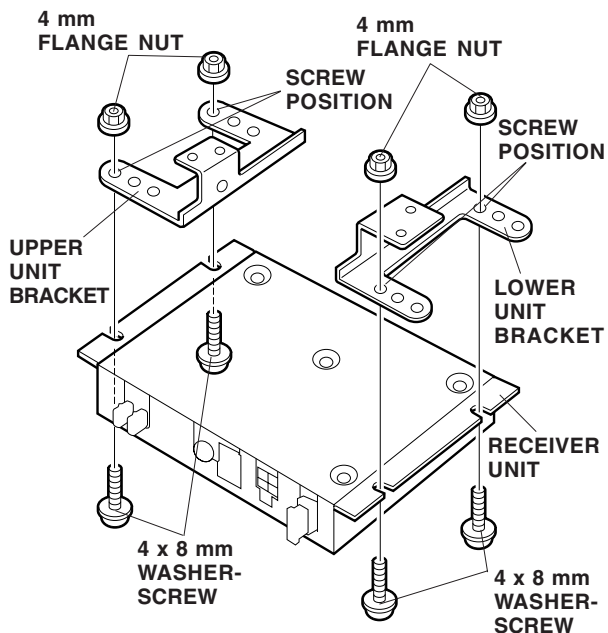

75. Position the receiver unit between the right trunk side panel and the rear fender panel, and plug in the antenna cable connectors, the DIN cable connector, and the XM radio harness connector using the panel hole to access the receiver unit.

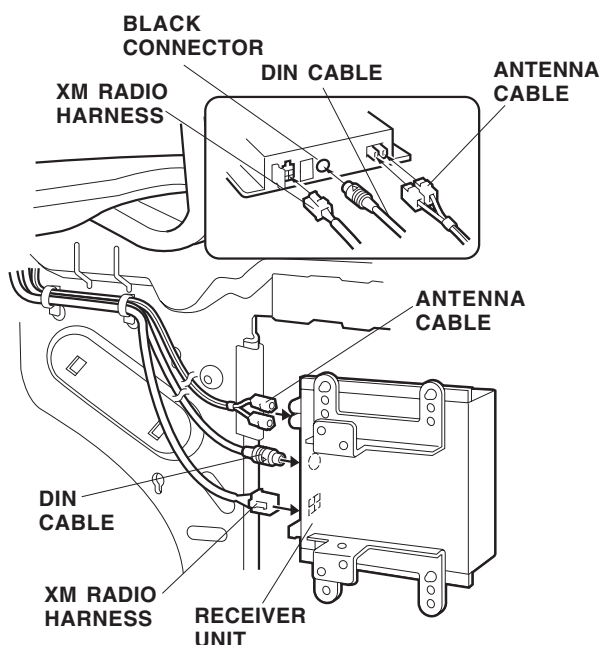

76. Secure the antenna cable, the XM radio harness, and the DIN cable with two wire ties with clip at the measurement shown. Press the clips of the wire ties into the trunk side panel hole and upper unit bracket hole.

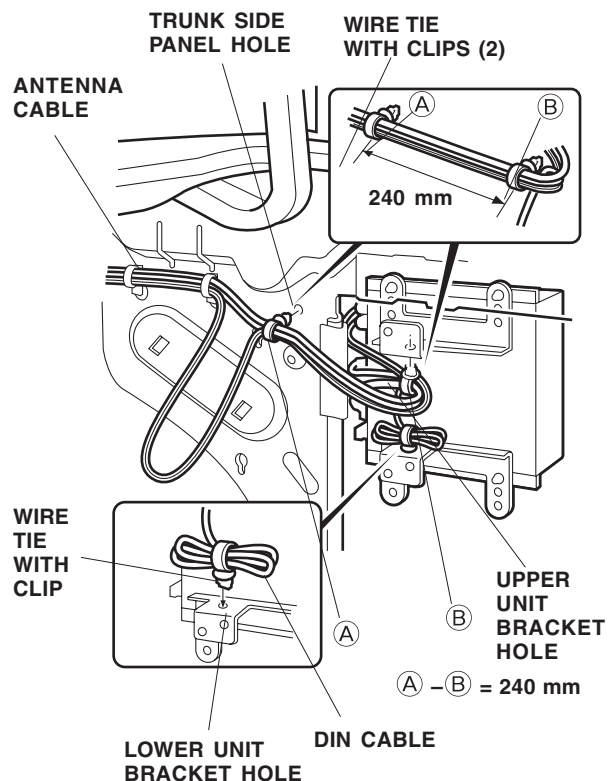

77. Fold the excess DIN cable, and secure it to the lower unit bracket with one wire tie with clip.
78. Attach the receiver unit/brackets using two 6 x 12 mm washer-bolts through the trunk side panel holes. Tighten the bolts securely.

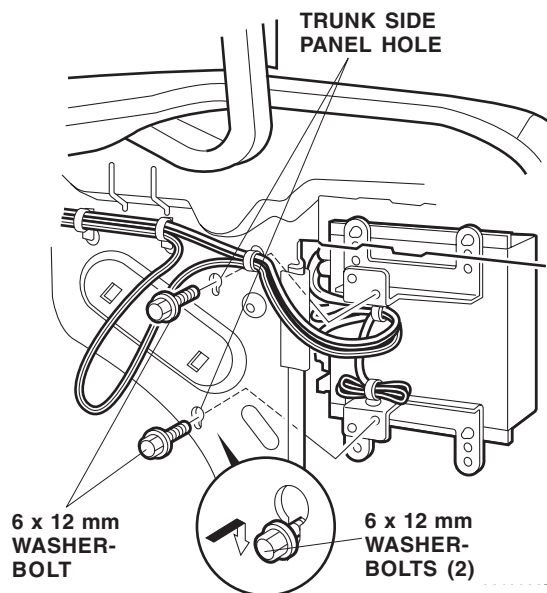

79. Fold any excess antenna cable, and wrap the excess cable with two EPT sealers. Secure the antenna cable to the XM radio harness with two wire ties in the areas shown. Tighten the off set wire ties you loosely installed in step 72.

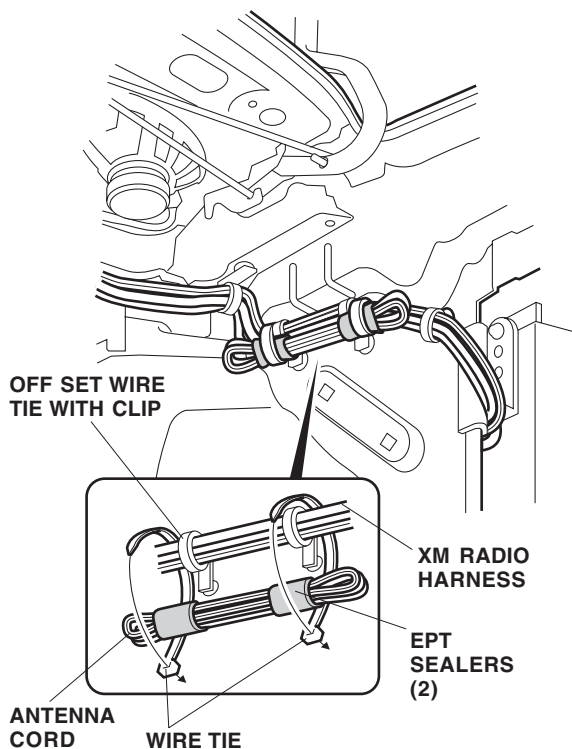

80. Install the 5A fuse provided into the No. 33 slot of the fuse box.

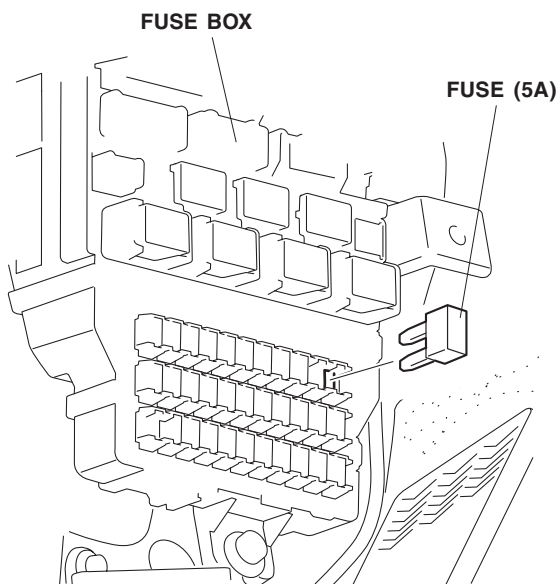

81. Attach the 5A fuse label over the No. 33 position on the fuse box cover.

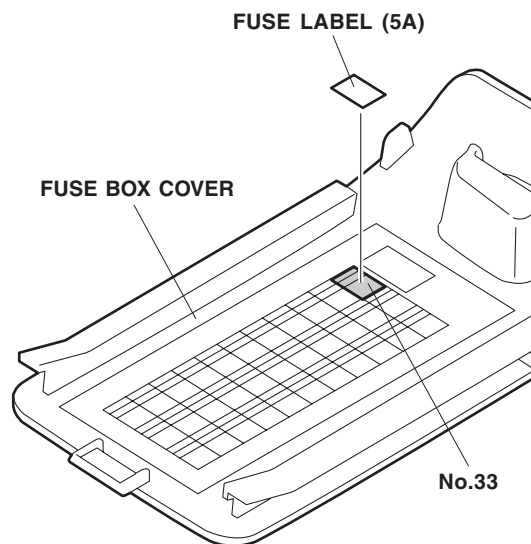

82. Check that all wire harnesses and cables are routed properly and all connectors are plugged in.
83. Reinstall all removed parts. Check that all clips and fasteners are installed securely.
84. Reconnect the negative cable to the battery.
85. Enter the radio anti-theft code, and reset the customer's radio station presets.
86. Set the clock.
87. Set one of the radio station presets to FM 88.7, and check the operation of the XM radio. If necessary, use the XM radio Owner's Manual supplied.

**NOTE:** Whenever the battery is disconnected, the driver's window AUTO up function is disabled.

88. Do the driver's window AUTO up procedure:
- Start the engine. Push down on the driver's window switch until the window is fully open.
  - Pull up on the driver's window switch to close the window completely, and hold the switch for 2 seconds or more.
  - Test the window AUTO up function.