

**INSTALLATION  
INSTRUCTIONS**

Accessory	Application	Publications No.
<b>REAR CAMERA ATTACHMENT KIT</b>	<b>2004 ODYSSEY</b>	<b>All 26021</b>
		Issue Date <b>AUG 2003</b>

**PARTS LIST**

**Rear Camera Attachment Kit:  
P/N 08B21-S0X-100**

Rear camera cover

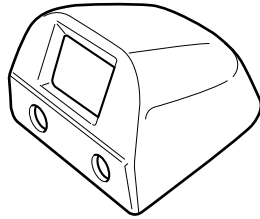

Rear camera bracket

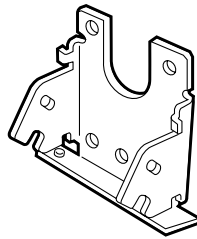

Rear camera subbracket

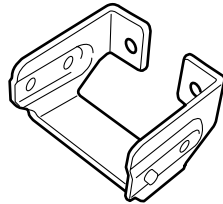

Control unit bracket A

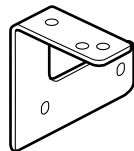

Control unit bracket B

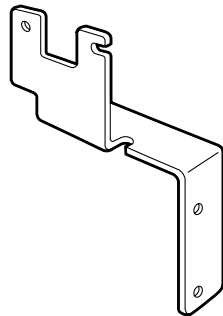

Control unit harness

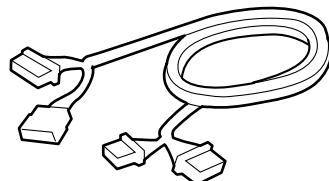

Rear camera subharness

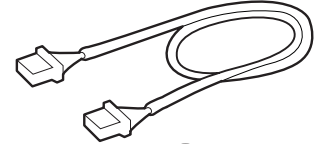

3 Washer-screws, 4 x 14 mm



2 Washer-screws, 4 x 6 mm



3 Blind nuts



4 Washer-screws, 5 x 8 mm



3 EPT sealers

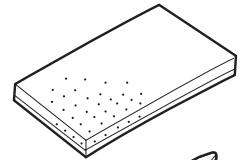

5 Short wire ties

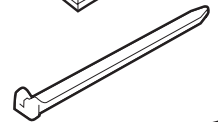

24 Wire ties

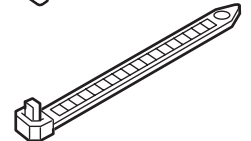

Template

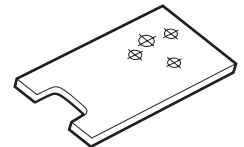

2 Allen bolts



Wire tie with clip

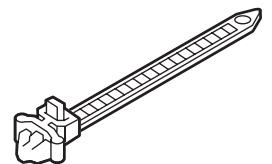

**Rear Camera Kit (sold separately):  
P/N: 08A21-2D1-100**

Rear camera

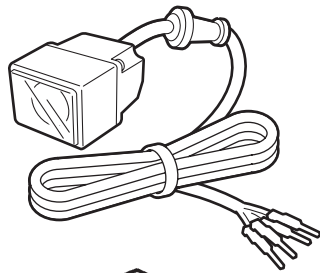

Control unit

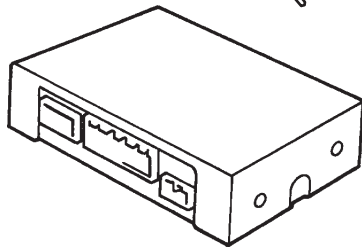

4-Pin connector

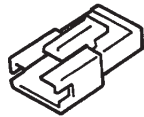

2 Washer-screws, 3.5 x 6 mm



Owner's Manual

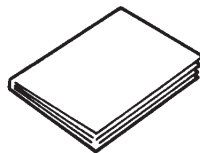

**TOOLS AND SUPPLIES REQUIRED**

- Phillips screwdriver
- Flat-tip screwdriver
- Small flat-tip screwdriver
- 6 mm, 8 mm, and 10 mm combination wrenches
- T-handle wrench
- 8 mm and 10 mm Sockets
- Scissors
- Shop towel
- Drill
- 3 mm, 8 mm, and 10 mm Drill bits
- File
- Electrical tape
- Isopropyl alcohol
- 3 mm Hex wrench
- Touch-up paint
- Center punch
- Torque wrench
- Piece of steel wire
- Utility knife
- Clip removal tool
- Masking tape

# Illustration of Rear Camera Installed on the Vehicle

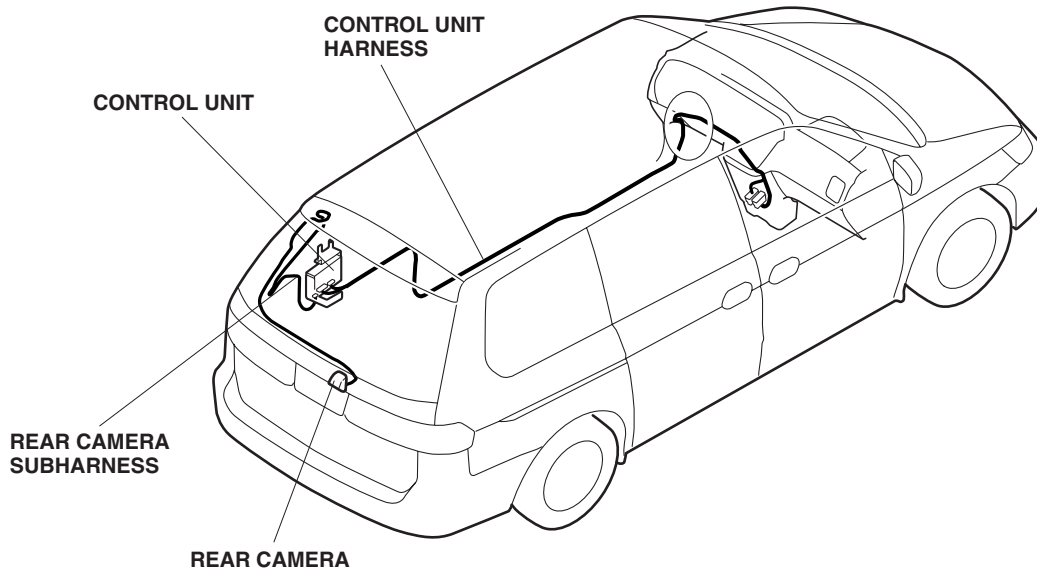

## System Diagram

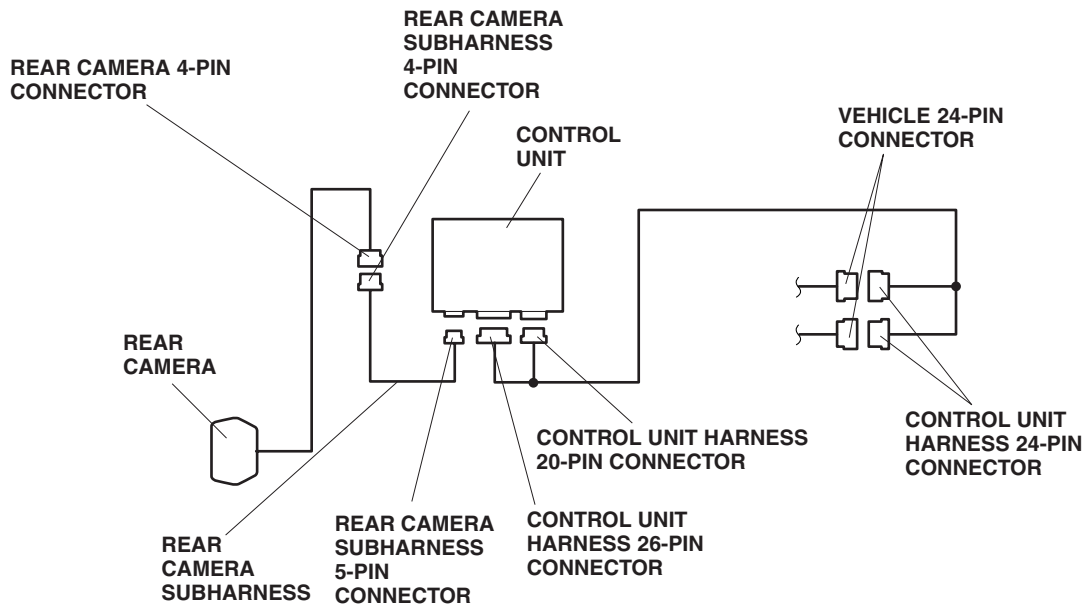

## INSTALLATION

**Customer Information:** The information in this installation instruction is intended for use only by skilled technicians who have the proper tools, equipment, and training to correctly and safely add equipment to your vehicle. These procedures should not be attempted by “do-it-yourselfers.”

1. Make sure you have the anti-theft code for the radio, then write down the frequencies for the preset buttons.
2. Disconnect the negative cable from the battery.
3. Open the tailgate, release the eleven clips, and remove the right and left tailgate side trims and tailgate upper trim.

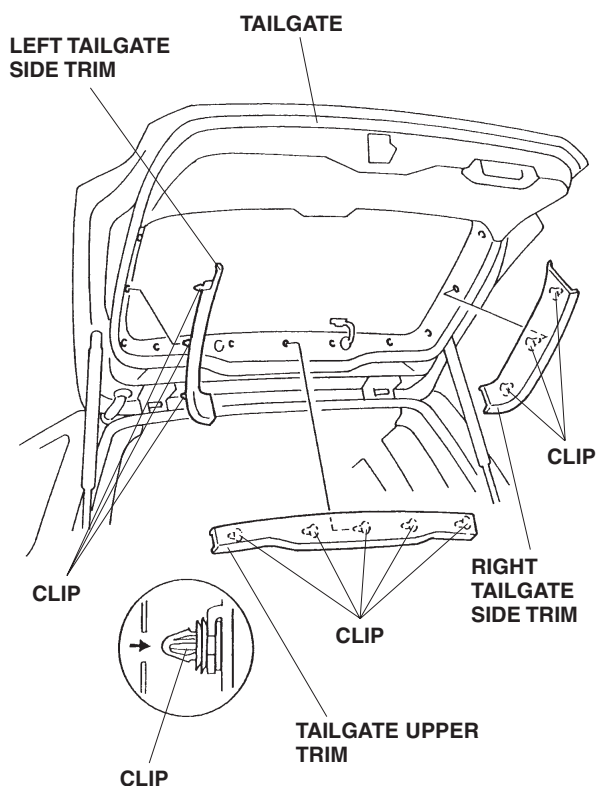

4. Remove the tailgate lower trim:
  - Remove the grab rail by removing the two caps and two screws concealed under the caps.
  - Pry up on the 11 clips, and remove the tailgate lower trim by pulling it upward.

NOTE: If the rod becomes disconnected from the clip when you remove the tailgate lower trim, reconnect the rod to the clip.

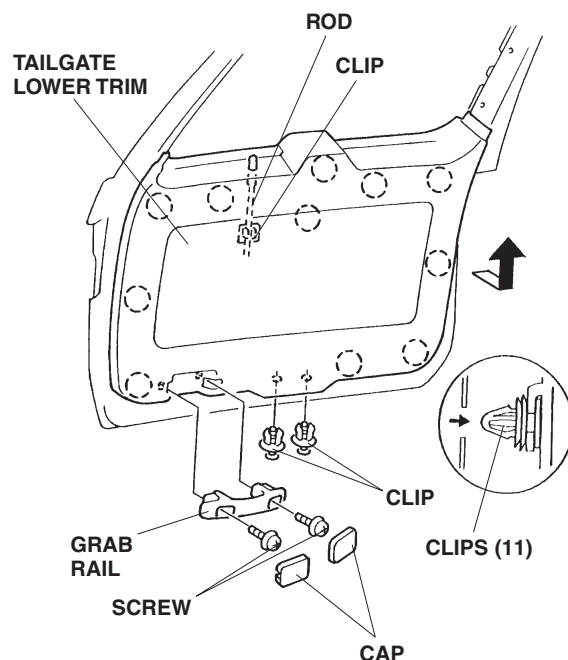

5. Remove the weatherstrip in the area shown, then remove the rear panel lining by removing the anchor bolt, two self-tapping screws, two hooks, and ten clips.

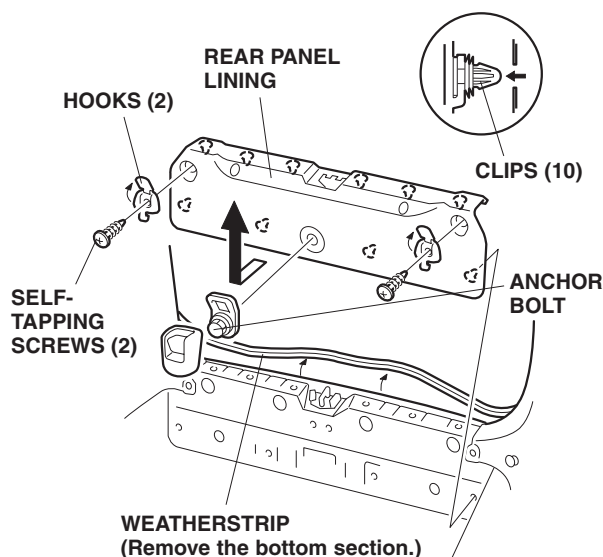

- Remove the jack cover, and take out the jack. Remove the two self-tapping screws and one hook.

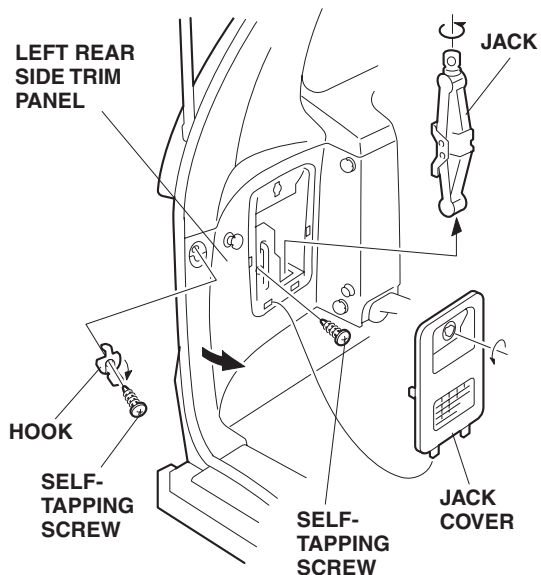

- Lift the rear speaker grille up by inserting the end of a flat-tip screwdriver between the grille and the body panel. To prevent damage, use a shop towel around the end of the screwdriver.

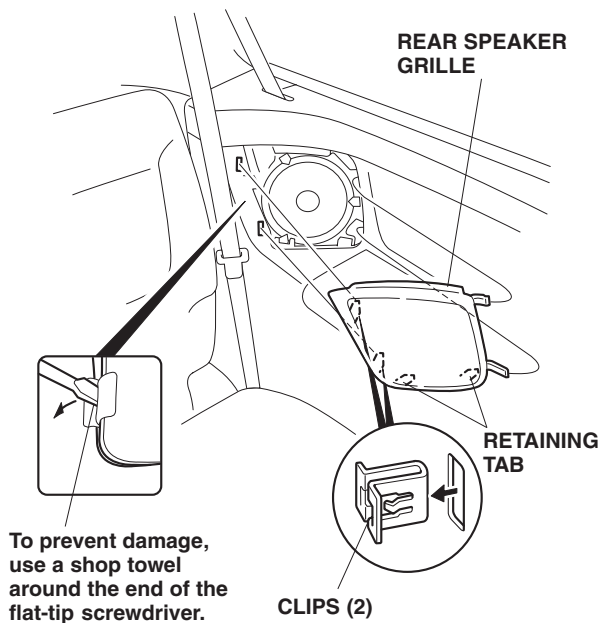

- Release the two retaining tabs and two clips, then remove the speaker grille by pulling it toward you. Take care not to damage the clips and speaker grille.

- Remove the three bolts that secure the rear speaker, pull the speaker out toward you, unplug the vehicle 2-pin connector, and remove the speaker from the panel.

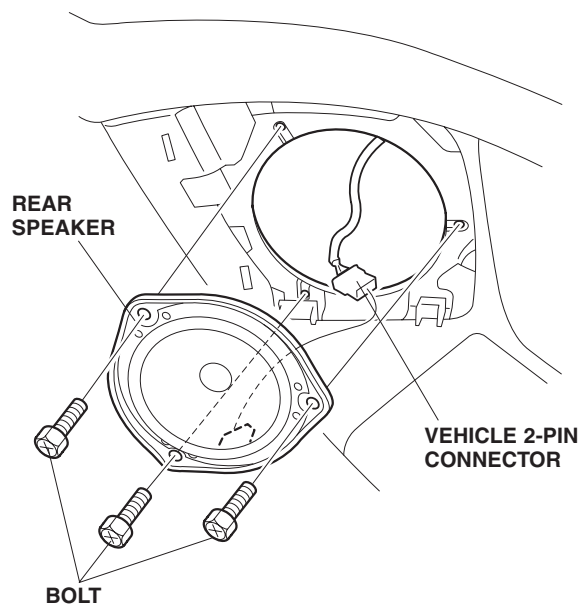

- Fold and store the third seat.

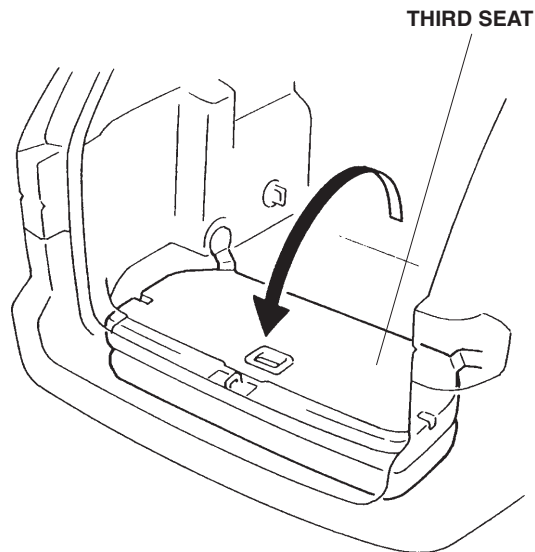

11. Remove the left second seat. Pull up the seat-back angle adjustment lever, and fold the seat-back forward. Unlock the seat from the floor by pulling the lock release lever under the seat cushion's front edge and lifting the rear of the seat.

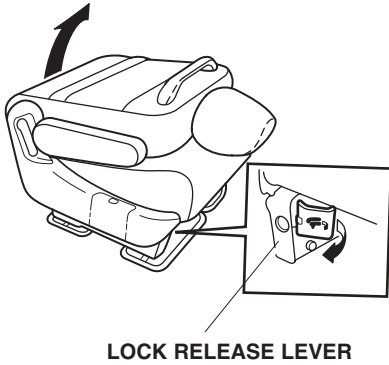

12. Unhook the front of the seat from the floor by pulling it back slightly, then pivoting it upward.

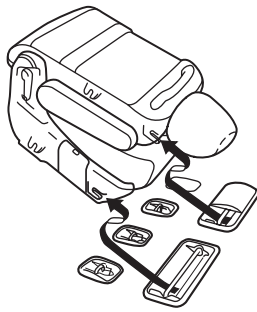

13. Pry up on the three clips, and remove the left sliding door sill trim.

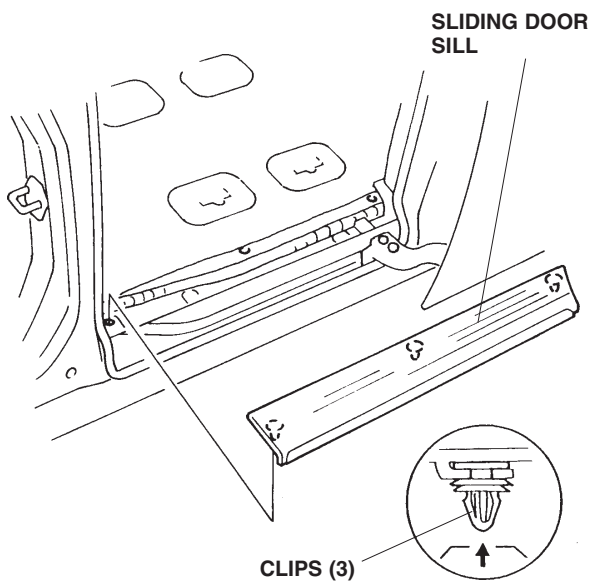

14. At the tailgate opening, remove the weatherstrip in the area shown. Release the two hooks and four retaining tabs that secure the rear of the left rear side trim panel, and gently bend the trim panel outward. Remove the brake light failure sensor from the panel.

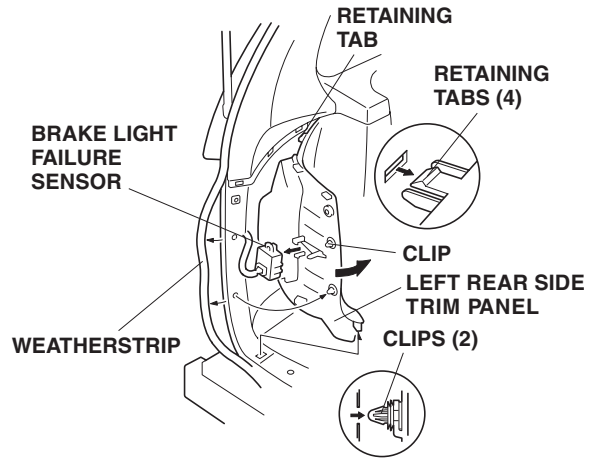

15. Remove the two seat belt anchor bolts and one self-tapping screw. Attach electrical tape to the seat belt anchor bolts.

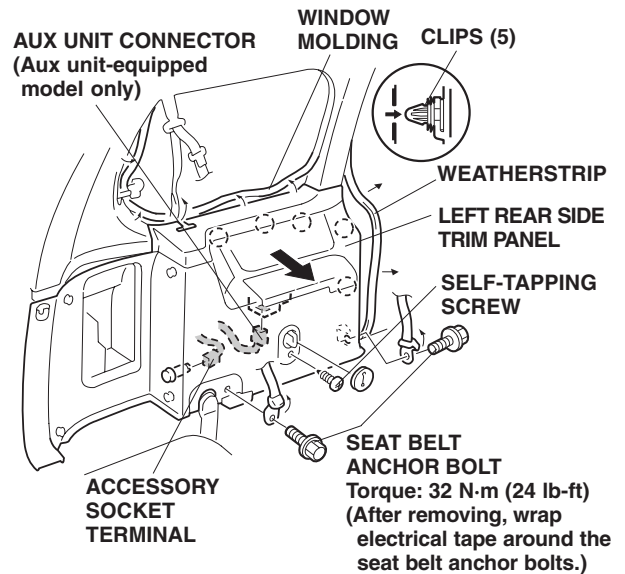

16. Remove the quarter window molding and weatherstrip in the areas shown. When removing the molding, take care not to get the sealant on your fingers or the panel.

17. Pull the left rear side trim panel out toward you to release the five clips. Unplug the vehicle accessory socket terminal and aux unit connector (aux unit-equipped model only), then remove the left rear side trim panel.

18. Remove the weatherstrip from the left rear pillar trim in the area shown, then release the four clips, and remove the left rear pillar trim.

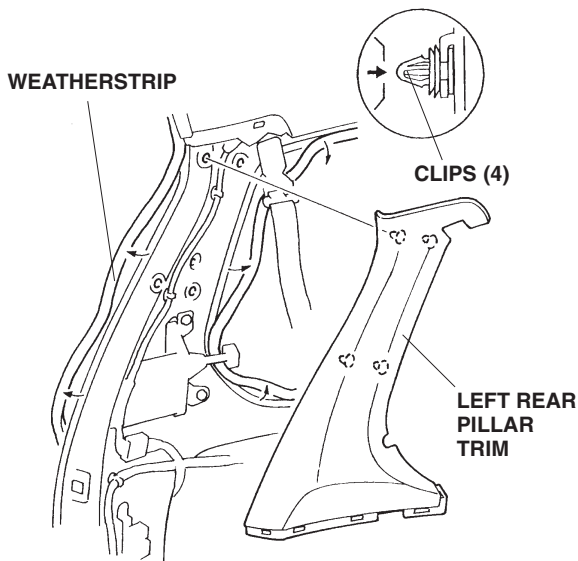

19. Remove the fuel fill door opener knob. Pry up on the four clips, and remove the driver's front door sill trim. Take care not to damage the clips.

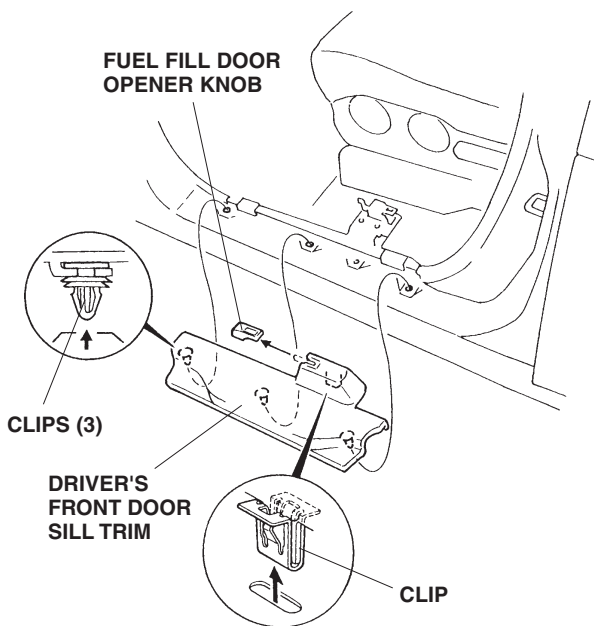

20. Remove the driver's side center pillar lower trim:

- Remove the front door opening trim and the sliding door opening trim around the center pillar lower trim.
- Slide the lower anchor cover upward, and remove the front seat belt lower anchor bolt.
- Gently spread open the top of the center pillar lower trim to release the two retaining tabs; then release the three clips, and remove the lower trim panel. Take care not to damage the clips and retaining tabs.

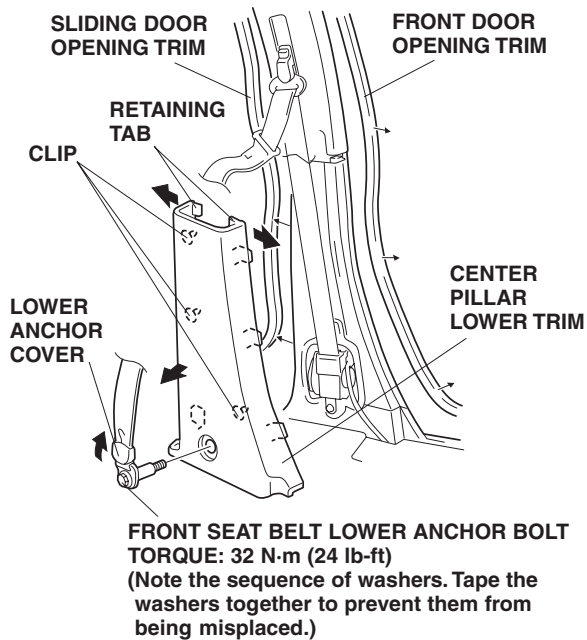

21. Pull up the left front door opening trim, and unscrew the plastic screw that secures the kick panel. Remove the kick panel by pulling it out toward you.

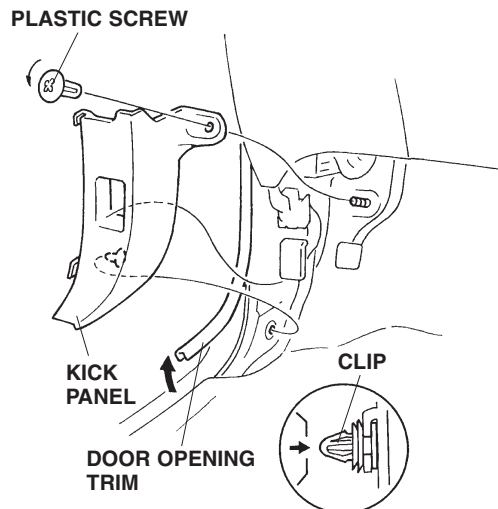

22. Open the cup holder. Using a flat-tip screwdriver, push up on the retaining tab at the bottom, and slide the cup holder out.

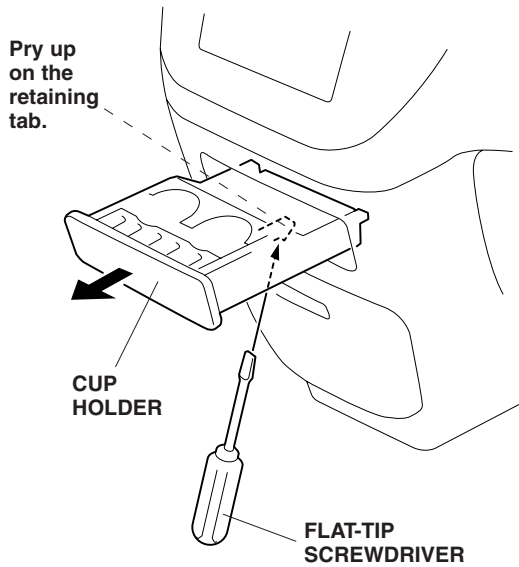

23. Pry out on the outboard clips of the center lower cover. Remove the center lower cover by releasing the two remaining clips.

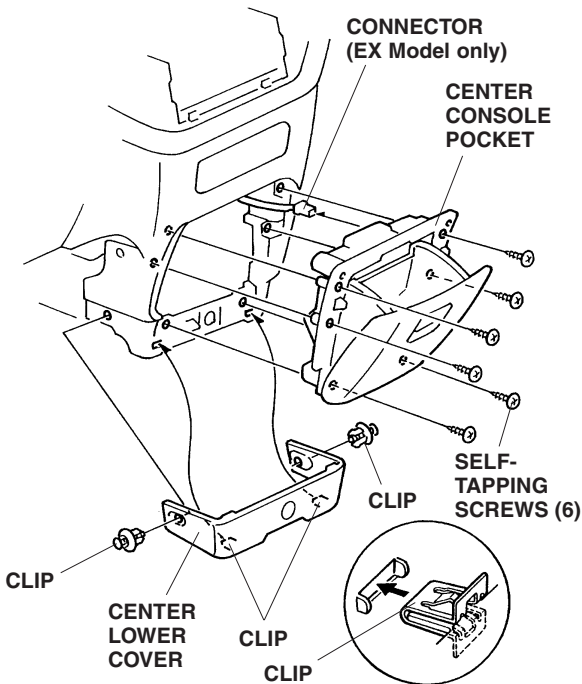

24. Open the center console pocket, and remove the six self-tapping screws. Disconnect the connector (if equipped), and remove the center console pocket.

25. Disconnect the accessory socket from the accessory socket harness connector, then remove the socket from the instrument panel by unscrewing the socket from the socket holder.

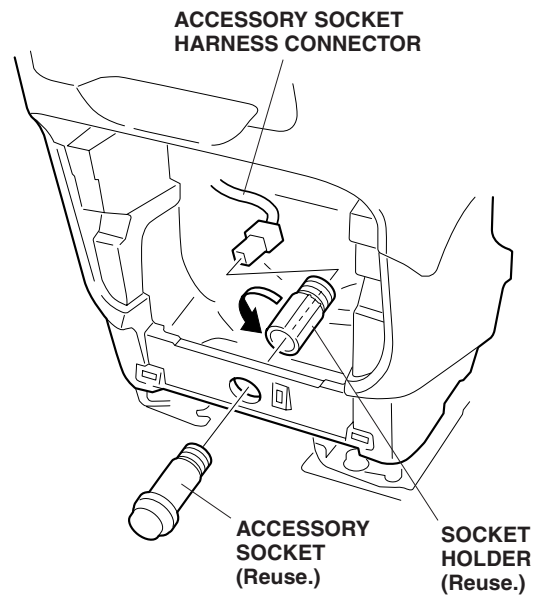

26. Remove the four self-tapping screws and the two bolts that fasten the center lower console, and remove the center lower console.

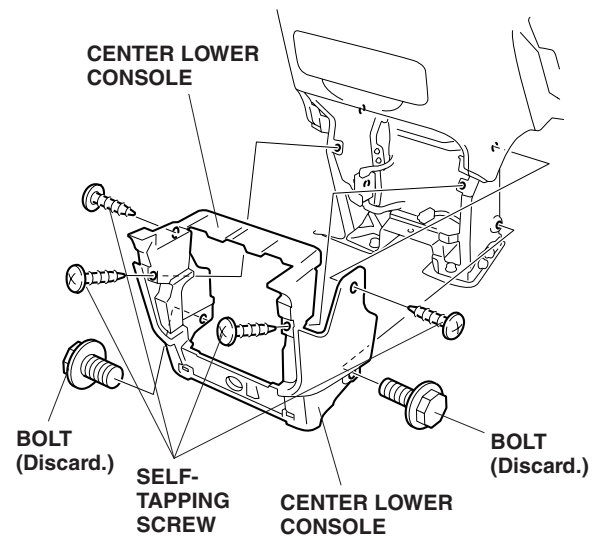



27. Position the template on the tailgate, and align it with the rear "H" emblem as shown. Attach the template to the tailgate with masking tape.

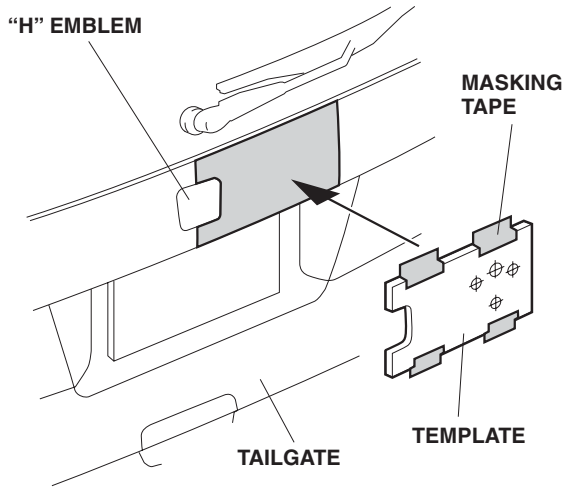

28. Lightly center-punch the tailgate at each of the four marks on the template. Remove the template from the tailgate.

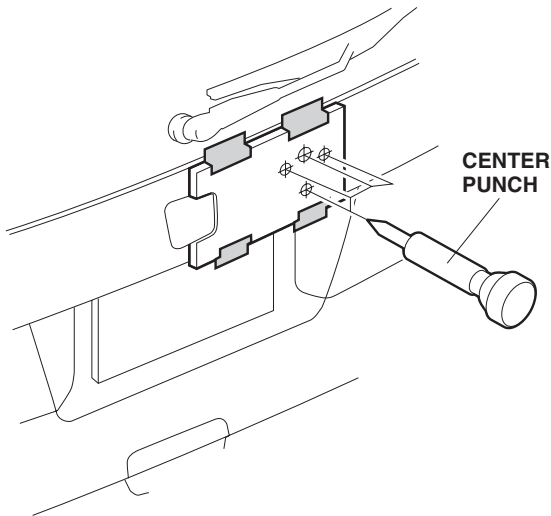

29. While wearing eye protection, drill three 8 mm holes and one 10 mm hole through the center-punched marks. Start with a 3 mm bit, and finally drill with an 8 mm bit in three places and a 10 mm drill bit in one place.

- To prevent drilling through the inner panel, wrap electrical tape around the drill bits at a point about 30 mm away from the tips.
- After drilling, remove any burrs from the edges of the holes with a file, and apply touch-up paint. Allow the touch-up paint to dry thoroughly before proceeding to the next step.

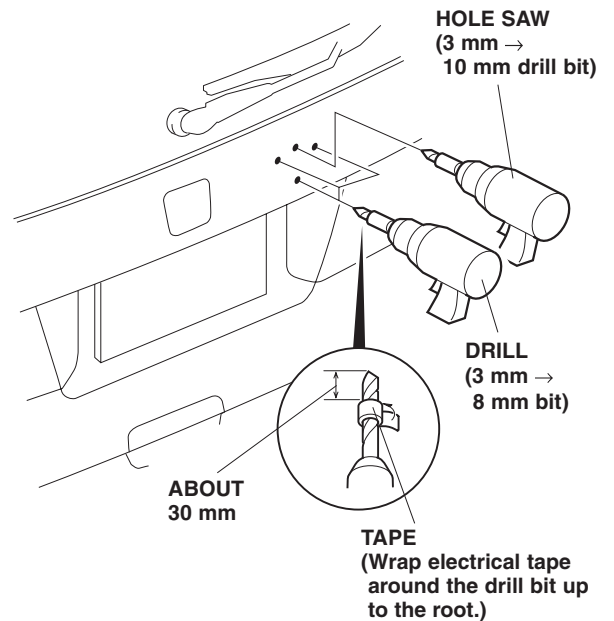

30. Slide a blind nut into each of the three 8 mm holes.

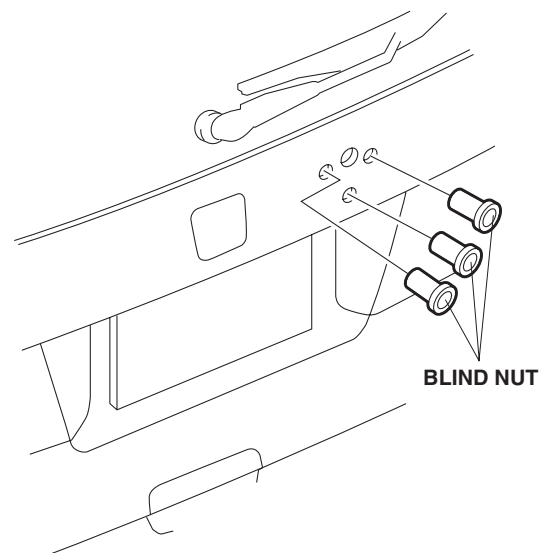

31. Get the rear camera. Using a tape measure and a felt-tip pen, measure and mark the harness 330 mm from the end.

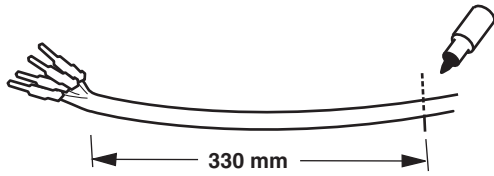

32. Position the camera bracket over the blind nuts, and install the three 4 x 14 mm washer-screws.

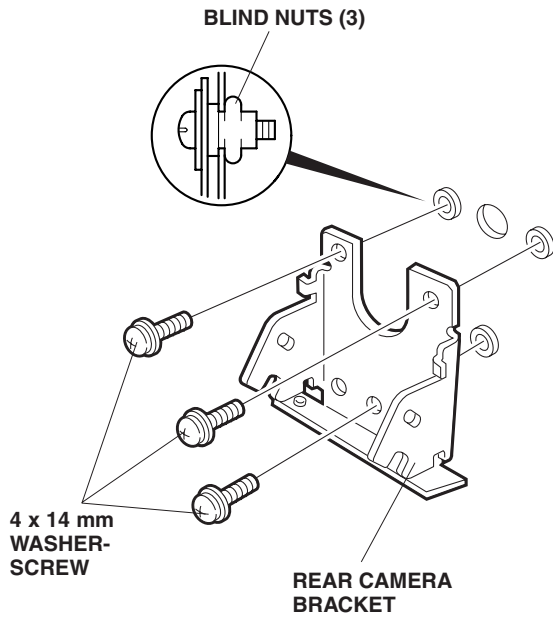

33. Slide the rear camera into position in the rear camera subbracket, and install the two 3.5 x 6 mm washer-screws included in the rear camera kit. Note the direction of the rear camera.

3.5 x 6 mm WASHER-SCREW  
(Included in the rear camera kit)

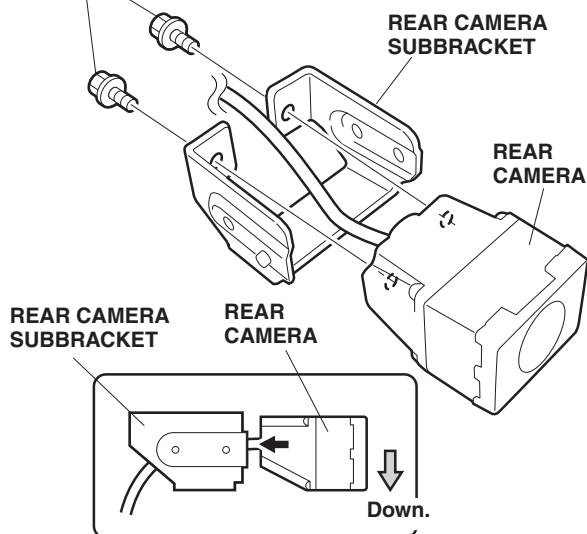

34. Align the two locating tabs of the rear camera subbracket with the slots in the rear camera bracket as shown, and install the two 4 x 6 mm washer-screws.

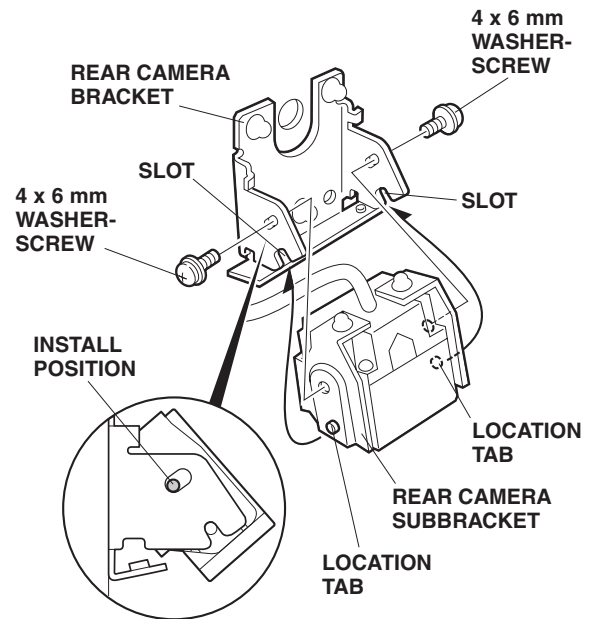

35. Route the wire harness from the rear camera through the 10 mm hole made in step 29. Seat the grommet on the harness in the 10 mm hole properly.

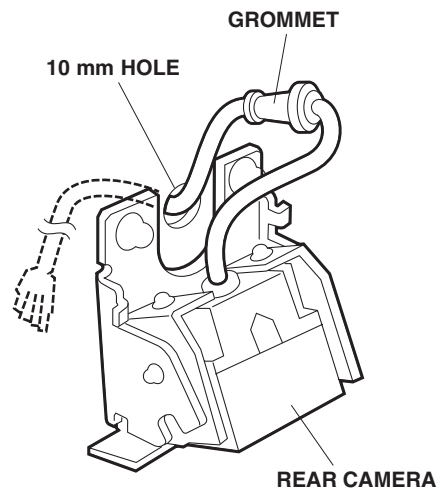

36. Behind the tailgate, route the camera harness along the vehicle harness, then secure the two harnesses with six wire ties in the areas shown.

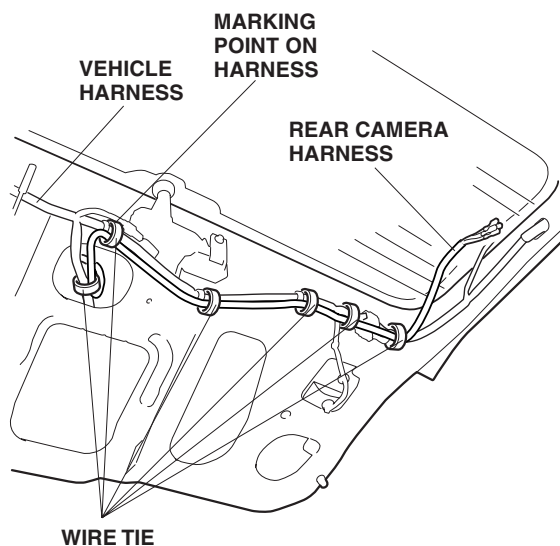

37. Continue to route the camera harness along the vehicle harness along the side of the tailgate, and secure the harnesses with two wire ties.

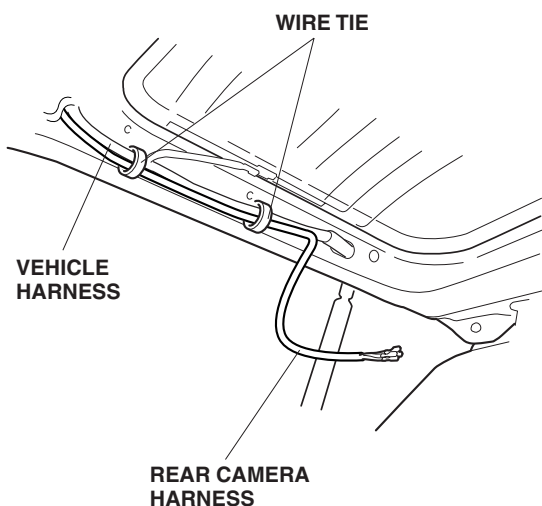

38. Remove the vehicle grommet from the tailgate.

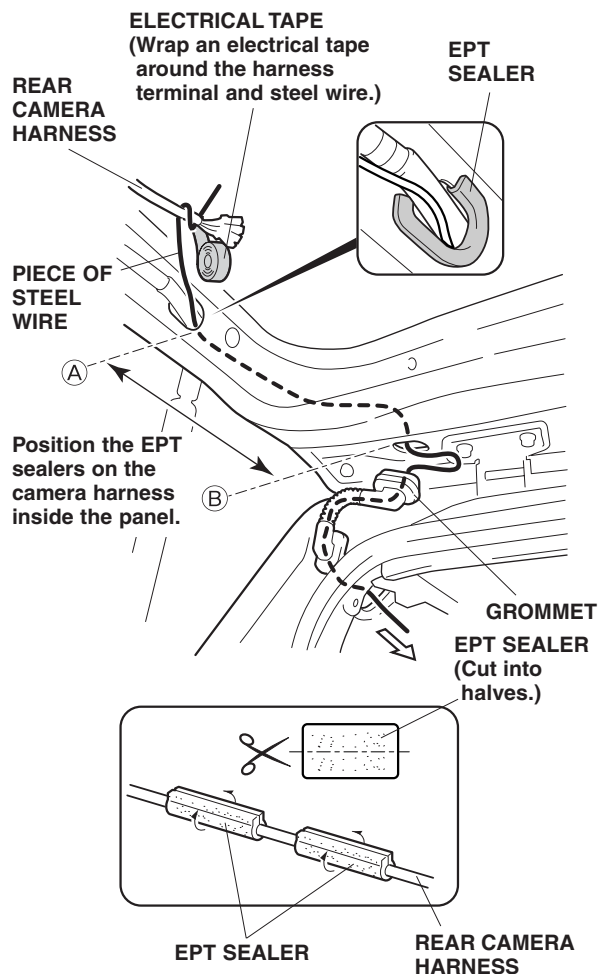

39. Using isopropyl alcohol, thoroughly clean the edge of the hole in the tailgate panel where the EPT sealer will be attached. Attach the EPT sealer to the edge of the hole.
40. Attach a piece of steel wire to the terminal end of the rear camera harness, then secure it by wrapping electrical tape around the harness terminal and steel wire.
41. Cut an EPT sealer in half. To prevent noise, wrap the two halves around the camera harness between the points (A) and (B) of the tailgate (inside the panel) as shown.
42. Route the rear camera harness through the tailgate panel and grommet into the cabin. Take care not to damage the grommets when routing the steel wire through the grommets.
43. Inside the cabin, remove the electrical tape from the harness terminal and steel wire.

44. Secure the camera harness to the vehicle harness with one wire tie in the area shown.

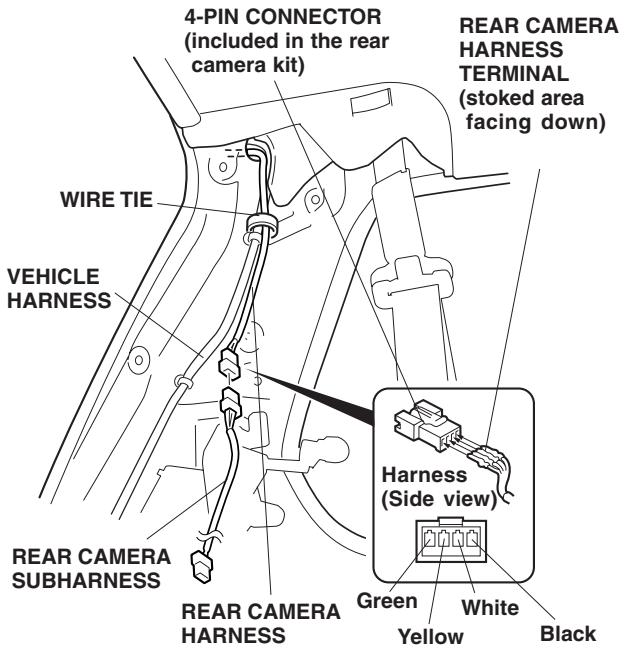

45. Plug the terminals of the camera harness into the appropriate ports of the 4-pin connector as shown, then connect the rear camera subharness to the 4-pin connector.
46. Cut an EPT sealer into halves, and wrap one piece around the 4-pin connectors you just connected.

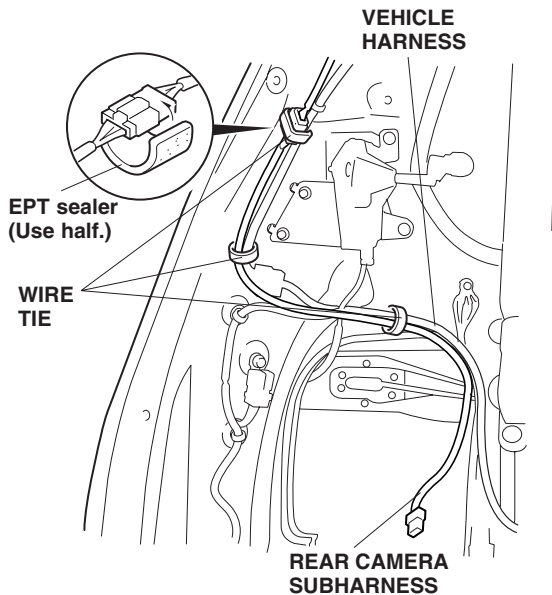

47. Secure the rear camera subharness to the vehicle harness with three wire ties in the areas shown.

48. Behind the vehicle panel, locate two nuts; remove the left nut, and loosen the right nut with a T-wrench by reaching through a maintenance access hole in the panel.

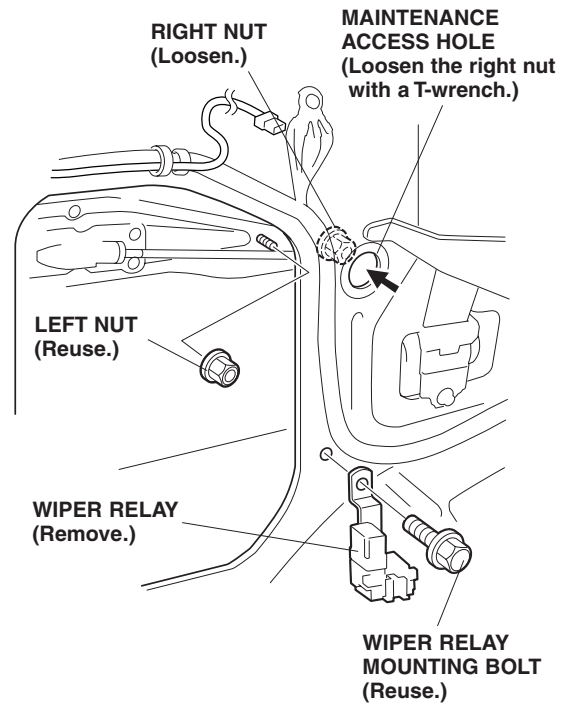

49. Remove the wiper relay by removing the wiper relay mounting bolt.
50. Position the control unit brackets A and B on the sides of the control unit, and temporarily install the two 5 x 8 mm washer-screws for each bracket.

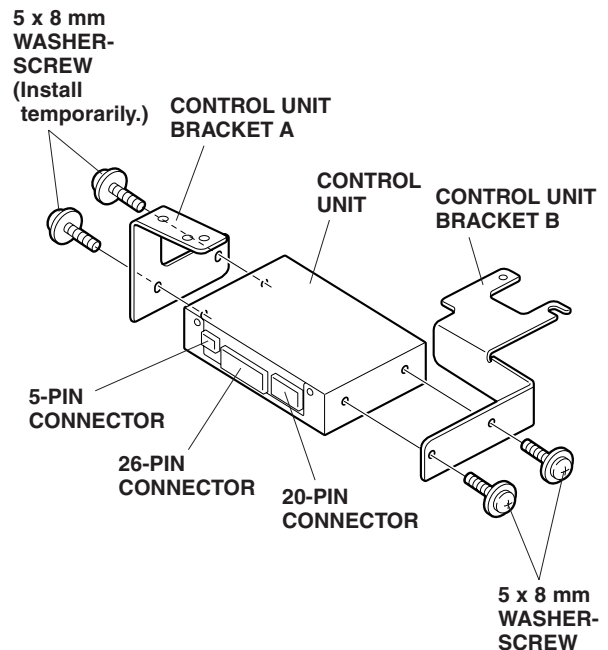

51. Temporarily attach the wire tie with clip to the rear camera subharness and control unit harness.

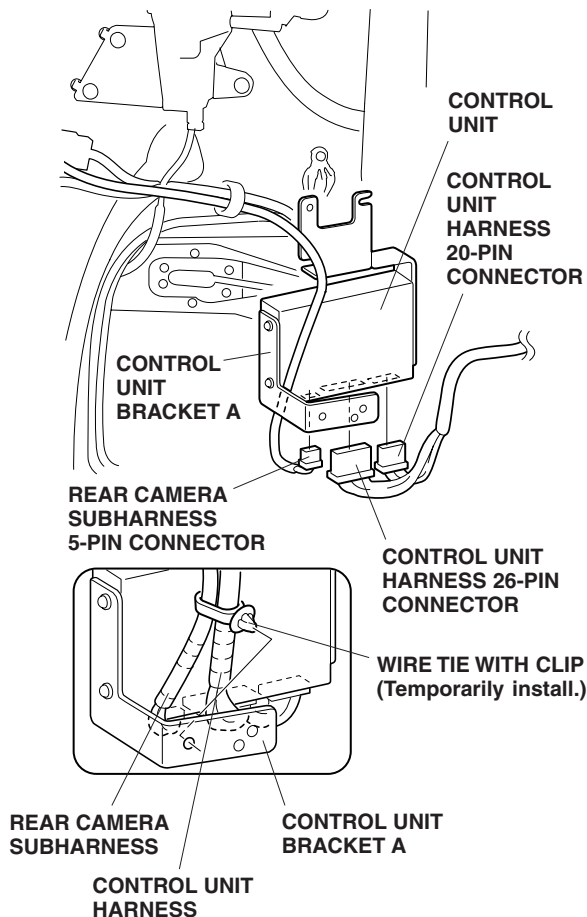

52. Plug the 5-pin connector of the rear camera subharness and the 26-pin and 20-pin connectors of the control unit harness into the rear of the control unit, then push the clip of the wire tie with clip into the hole in control unit bracket A.

53. Slide the slotted end of control unit bracket B into the clearance between the right nut loosened in step 48 and the vehicle panel.

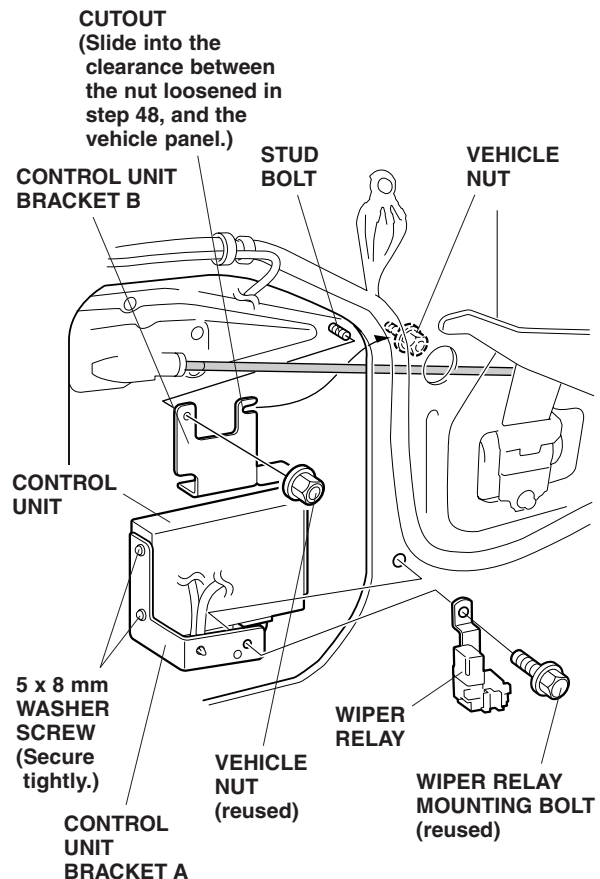

54. Slide the left hole in the control unit bracket B over the left stud from which the left nut was removed in step 48. Reinstall the left nut on the stud, but do not tighten it yet.
55. Temporarily attach control unit bracket A to the vehicle panel along with the wiper relay removed in step 49.
56. Secure the control unit to the vehicle panel by alternately tightening the bolts and nuts evenly in two to three steps.
57. Tighten the two 5 x 8 mm washer-screws temporarily installed on control unit bracket A in step 50.

58. Tightly squeeze the wire tie with clip temporarily installed on the control unit and rear camera harnesses in step 51, then secure the harnesses to the vehicle harness with three wire ties in the areas shown.

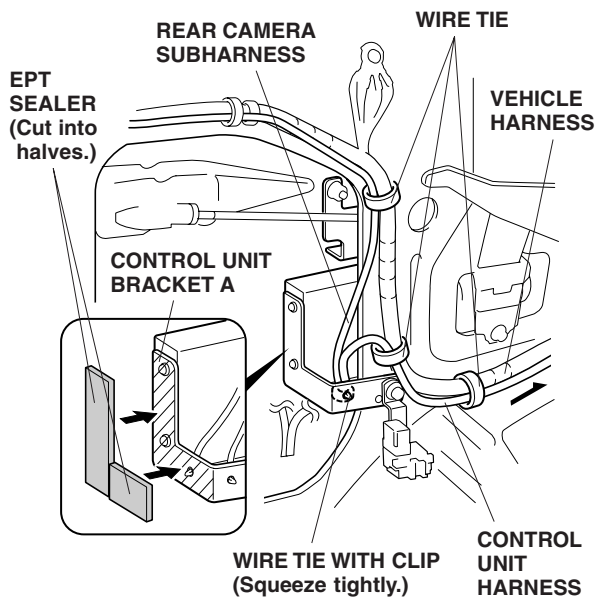

59. Using isopropyl alcohol, thoroughly clean the area where the EPT sealer will attach. Cut an EPT sealer in half, attach the two halves to control unit bracket A, as shown.
60. Route the control unit harness along the vehicle harness under the floor carpet in the front of the vehicle.

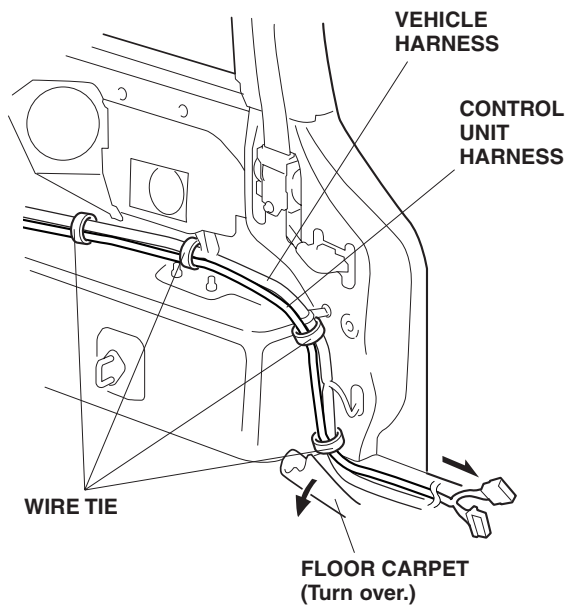

61. Secure the control unit harness to the vehicle harness with four wire ties as shown.

62. Route the control unit harness to the sill trim on the driver's seat side along the vehicle harness.
63. On the side of the left second seat, secure the control unit harness to the vehicle harness with three short wire ties in the areas shown.

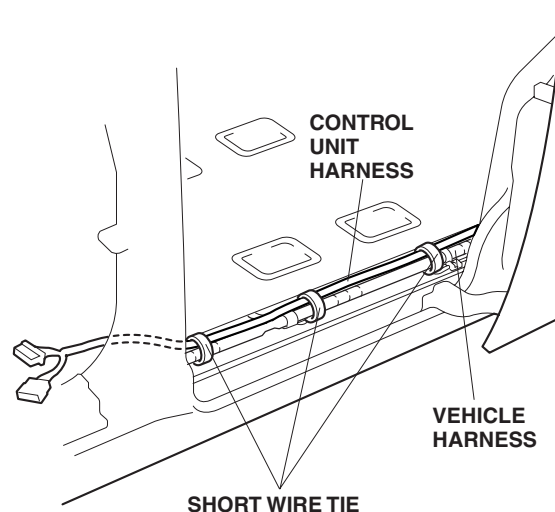

64. On the side of the driver's seat, secure the control unit harness to the vehicle harness with two short wire ties in the areas shown.

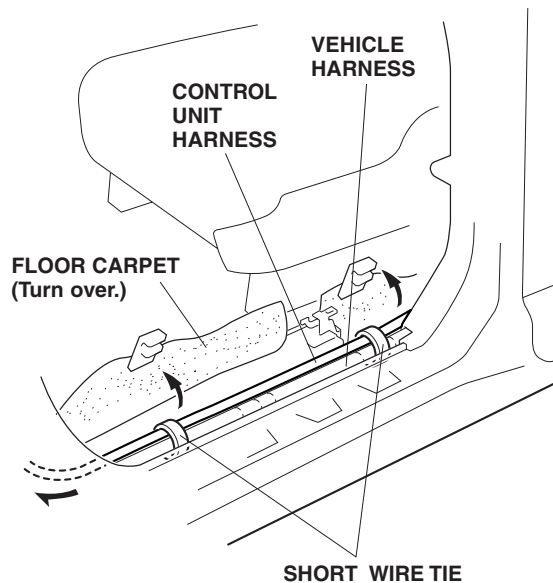

65. Route the control unit harness to the side of the fuse box, and secure it to the vehicle harness with three wire ties.

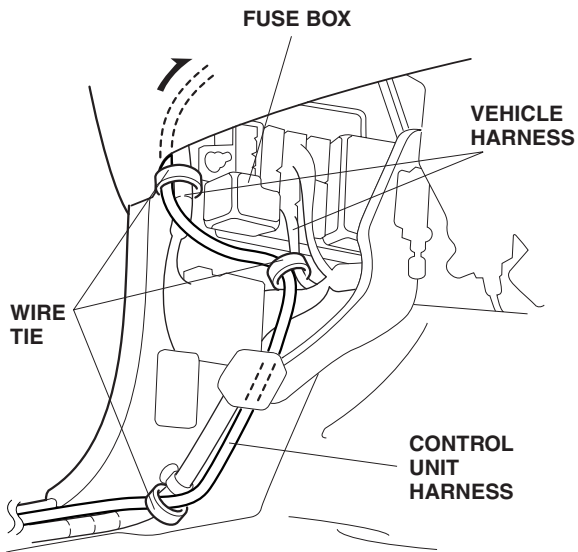

66. Route the control unit harness under the steering shaft to the center lower pocket opening, then secure it to the vehicle harness with three wire ties.

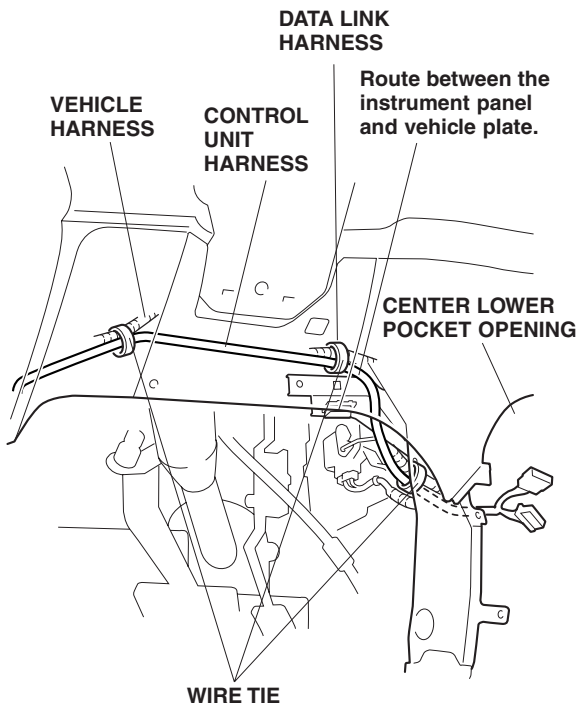

67. Unplug the vehicle 24-pin connector from the left of the center lower pocket opening.

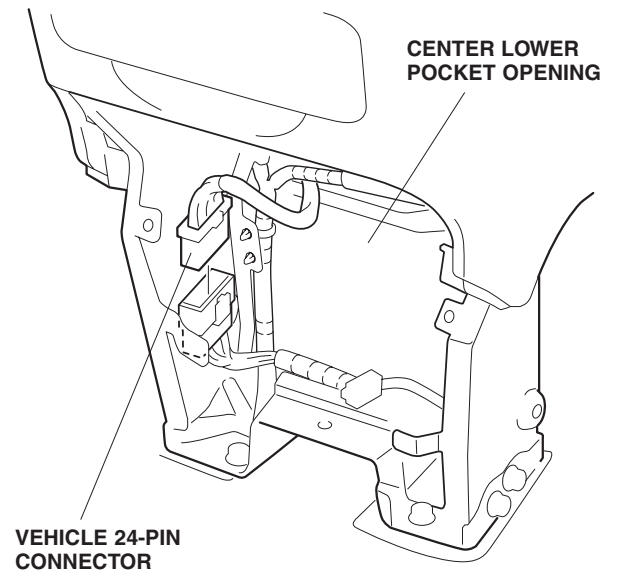

68. Plug the control unit harness 24-pin connectors between the vehicle 24-pin connectors you unplugged.

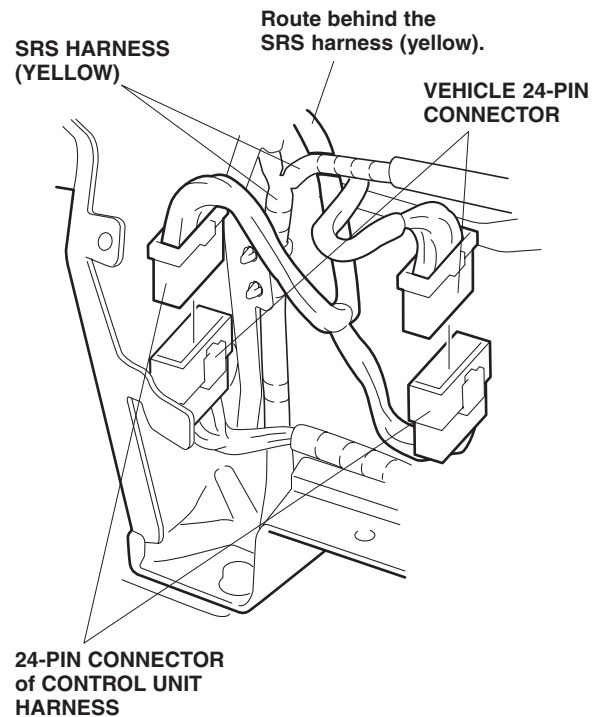

69. Plug the 24-pin connector of the control unit harness into the vehicle 24-pin connector (secured to the vehicle frame) from the top.

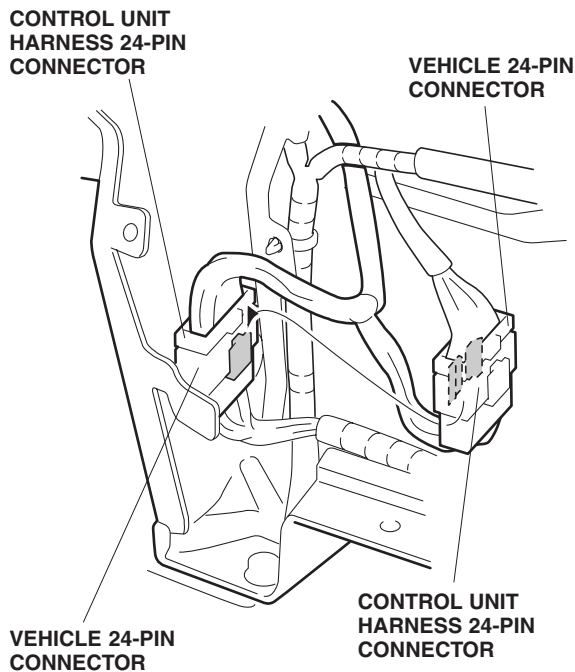

70. Wrap the remaining half of an EPT sealer (cut into halves in step 46) around the 24-pin connectors as shown.

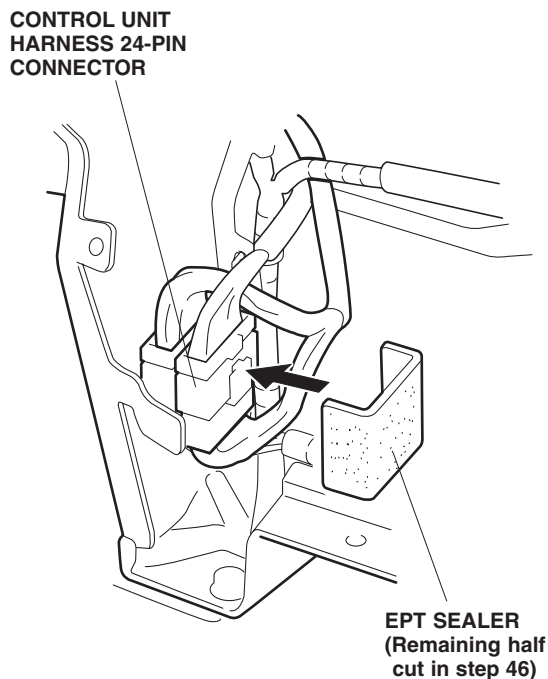

71. Install the camera cover with two Allen bolts, then check that the camera cover is shown evenly on the screen.

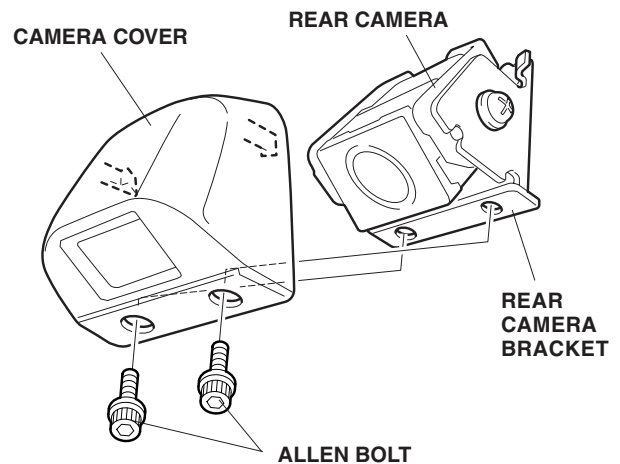

72. Reconnect the negative cable to the battery.
73. Reinstall all removed parts.
74. Enter the customer's radio anti-theft code, and reset the radio station presets.
75. Set the clock.
76. Check the operation of the rear camera according to the Owner's Manual supplied with the unit.
77. Put the Owner's Manual in the glove box.

NOTE: Whenever the battery is disconnected, the driver's window AUTO function is disabled.

78. Start the engine. Push down on the driver's window switch until the window is fully open.
79. Pull up on the driver's window switch to close the window completely, then hold the switch for 2 seconds or more.
80. Check the operation of the driver's window AUTO function.
81. Do the idle learn procedure:
- Make sure all electrical items (A/C, audio unit, defogger, lights, etc.) are turned off, then start the engine.
  - Let the engine idle reach its normal operating temperature (the cooling fan cycles twice).
  - Let the engine idle (throttle fully closed and with all electrical items off) for 10 minutes.

NOTE: If the radiator fan comes on during this step, the time when it is operating must not be included in the 5 minutes.